



ENERGIS SLIMLINE VISTA+

**Heater Suitable For Natural Gas at Inlet Pressure 20mbar
or Propane at Inlet Pressure 37mbar**

Tested & Approved by BSI to BS7977-1:2009+A1:2013

USE, INSTALLATION & SERVICING INSTRUCTIONS

Important

**A Carbon Monoxide Alarm Complying With BS EN 50201 Must Be Provided
In The Room Where The Gas Fire Is Installed.**

It Must Be Fitted And Maintained In Line With The Manufacturer's Instructions.

All Propane (LPG) Installations Should Be Fitted with a Over Pressure Shut Off Valve (OPSO).

The outer parts of this fire will become hot during use, cloths or combustible items must not be placed close to or on the fire. We recommend that a Fireguard conforming to BS8423 should be used for protection of Young Children the Elderly, Infirm and Pets.

**ALL INSTRUCTIONS MUST BE LEFT WITH THE USER FOR
SAFE KEEPING**

MANUFACTURED by:

Nu-Flame Limited

Unit 4, Kimpton Trade & Business Centre

Minden Road, Sutton, Surrey SM3 9PF

Tel: 020 8254 6802

Fax: 020 8641 9992

Email: sales@nu-flame.co.uk

Country of Destination - GB & IE

CONTENTS

Section No	Subject	Page
User Section		
-	Contents Page	2
-	Box Contents	2
-	Fitting Kit Contents	3
1	Important Notes	4
2	Lighting & Controlling the Fire	5
3	Cleaning the Fire	7
4	Servicing	7
Installation Section		
-	Record Data	7
-	Site Surveying	8
5	Installation Requirements	9
6	Appliance Data	9
7a	Appliance Dimensions	9
7b	Frame Front & Trim Dimensions	10
8	Fret Requirements	11
9	Flue Requirements	11
10	Ventilation	11
11	Gas Supply	12
<i>Sections 12 - 15 are for the various installation applications - Ensure you refer to the section relevant to your requirement</i>		
12	Class 1 & Lined Flue Fire Surround Application Fireplace Construction	13
13	Pre-Cast Fireplace Application - Fireplace Construction (Rebated or Purpose Built Fire Surround & Construction)	14
14	BS715 Shallow Flue Box with 5" Twin Wall Flue Application (Fireplace or Hole in the Wall Construction)	16
15	Hole in the Wall Application into Class 1 & Lined Flue Builders Opening Construction	18
16	Fixing the Fire	19
17	Arrangement of the Fuel Effect	22
18	Testing, Commissioning & Use	26
19	Briefing the Customer	26
20	Servicing	26
21	Fault Finding Guide, Symptoms & Possible Cause	27
22a & b	Energy Class & Product Fiche	29
23a & b	UK & EU Declaration of Conformity	31
24	Diagram of Infrared Control System	33
-	Guarantee	34

BOX CONTENTS

The Fire comes in 1 box containing the Fire with chosen Control and Fitting kit (see next page for fitting kit contents) plus the Fuel Bed Components Left & Right Matrix's, Coals, and Fret if ordered may come in a separate box.

THE ENERGIS SLIMLINE VISTA+ FITTING KIT CONTENTS:

Cable Fixing Kit (2 # cables and fittings, 4 # eyebolts, 4 # screws and 4 # plastic plugs).

2 # Flue Restrictors. One for Natural Gas marked (NG) and one for Propane marked (P) Applications.

2 # No8 x 10mm pointed self tapping screws for the restrictor.

4 # Magnets for holding Front Trim on.

1 # 2,050mm length of 6mm x 4mm self adhesive silicone sealing strip.

1 # 10mm Back Nut & olive to connect 8mm copper pipe gas supply to the burner (via the isolation elbow).

1 # Set of Instructions / Warranty.

THE ENERGIS SLIMLINE VISTA+

USER INSTRUCTIONS

1. - IMPORTANT NOTES

- a. This appliance must be installed by a properly qualified (in accordance with National & Local Regulations) Installation Engineer.
- b. The connection of this appliance and ventilation requirements (if any) are to be according to National & Local Codes.
- c. This appliance does not normally require any purpose provided additional ventilation, however if it has been found necessary to add a vent periodically check that it is free from obstruction.
- d. Consult all Instructions before Installation and Use.
- e. Do not throw rubbish on, or attempt to burn any materials on this appliance. Any Debris or Foreign Matter must be removed from the fire.
- f. Under No Circumstances must this fire be used if the Glass Panel is broken, damaged, cracked or has been removed.
- g. The outer parts of this fire will become hot during use, cloths or combustible items must not be placed close to or on the fire. We recommend that a Fireguard conforming to BS8423 should be used for protection of Young Children the Elderly, Infirm and Pets.
- h. For Fires Installed above floor level, (Hole in the wall Fires), it is recommended that a means, (tactile separator/shelf or guard) is provided to give abrupt warning to a person moving inadvertently towards the fire.
- i. The appliance should be Serviced Annually in accordance with the Gas Safety & Uses Regulations.
- j. Where the flue has been used for Solid Fuel it must be swept before Installation.
- k. If at any time you smell gas or fumes turn the fire off and contact your Installer.
- l. These Instructions must be left with the User for future reference.
- m. During its first period of use any protective coatings and oils will burn out of the appliance and it is wise to ventilate the room for the first hour of use.
- n. This appliance is fitted with an oxygen depletion sensing system, which automatically shuts off the gas supply to the fire if the oxygen level in the room is depleted, due to lack of primary air, or obstructed flue (blocked chimney) that would lead to incomplete combustion of the gas. It must not be tampered with and only replaced with a genuine Nu-Flame ODS.
- o. In the event that the fire shuts down for any reason, attempt to restart it. If there is a continuing problem, call in a properly qualified specialist engineer.
- p. There are no user replaceable parts in the appliance apart from the batteries, if a High Level or Thermatronic Electronic Control System was ordered.
- q. The chimney should be regularly checked to ensure that all the products of combustion are entering the flue & that there is no build up of soot. If there is, the appliance must be serviced.
- r. The Coal fuel effects, manufactured from refractory fibre, are supplied with this appliance. Do not use real coals as this is dangerous. If the simulated fuel bed components need renewing please obtain suitable replacements from a Nu-Flame Stockist. The Coals are prone to discolouration, this is quite normal.
- s. The fire must be installed in accordance with the rules in force and these Instructions it must be installed into a fireplace or builders opening as detailed in these Instructions.
- t. No combustible materials e.g. curtains must be closer than 500mm to the fire.
- u. For Fire Surround Applications a 150mm (6") combustible shelf can be fitted above the fire provided it is 150mm above the Fireplace Opening.
- v. The Fire can be installed into a suitably designed fire surround with a 150°C Rating.
- w. Explain to the customer that over time some wall staining will occur above the fire and this is due primarily to particles of dust present in the hot convection air circulating up and over the fire/surround and sticking to the wall.

! IMPORTANT! THE GLASS WILL BECOME VERY HOT DURING OPERATION.

Under No Circumstances must this fire be used if the Glass Panel is broken, damaged, cracked or not fitted.

It is quite normal for the fire to make popping and burbling sounds when in use, as would a solid fuel fire.

PLEASE BE AWARE

Over Time The Stainless Steel Trim Around The Glass Panel Will Change Colour To Pale Straw Colour Which Is Quite Normal.

Make the Customer aware that they will notice that after the first use the fuel bed components, e. g. Coals, Matrix & Liners will change colour and this is quite normal and part of the overall effect of simulating a real coal fire.

IMPORTANT SAFETY RECOMMENDATION

A Fireguard conforming to BS8423 should be used for protection of Young Children the Elderly, Infirm and Pets.

Health & Safety Advice Refractory Ceramic Fibre (RCF)

Advice when working with Fuel Bed Components including Installing, Servicing and Disposal.

The Fuel Effect parts and possible Linings of this fire are made from Refractory Ceramic Fibre (R.C.F.) a Class 2 Carcinogen which is a material designed for this Application. Excessive exposure to these types of materials may cause temporary irritation to eyes, skin and respiratory tract. Therefore take care when handling these articles to ensure dust is kept to a minimum. It is not necessary to wear protective clothing when handling these articles but we do recommend you follow the normal hygiene rules of not smoking, eating or drinking in the work area, and always wash your hands before eating or drinking. To minimise the release of RCF fibres during installation and servicing a HEPA filtered vacuum is recommended to remove any dust accumulated in and around the fire both before and after working on it. When Servicing and if replacing these parts we do not recommend they are broken up but are sealed within a heavy duty polythene Bag and labelled as "RCF waste". This is not classified as "hazardous waste" and may be disposed of at a local licensed landfill site.

2. - LIGHTING & CONTROLLING THE FIRE

General

The fire is available with 4 Control Options: a Manual Control (Fire is lit and adjusted manually), a side Trim fitted 2 Button High Level Control (Fire when lit can be controlled with the Push Buttons), a side Trim fitted 3 Button High Level Control (Fire can be lit and controlled with the Push Buttons) or ThermoTronic Radio Frequency Electronic Control System (Fire is lit and operated with the Handset). Some Models also have a Coal / Coke Effect Lever System see 2.7

2.1 - LIGHTING & CONTROLLING THE FIRE – MANUAL CONTROL

Remove the Ash Pan Cover to get access to the Control Knob used to operate the Fire.

- Switching On/Ignition.** Depress the control knob & turn counter clockwise. Gas will flow to the Pilot Burner (Pilot Burner is visible looking down through the glass at the left side), the Piezo Igniter will give off first one, then, as you turn, a second high voltage spark & the Pilot Burner will Light. (More than one attempt may have to be made on first lighting.)
Keep the Control Knob depressed for approximately 10 seconds to heat up the Thermocouple.
Turn the Control Knob fully counter clockwise to release gas to the Main Burner.
- Control of Gas Flow.** Turning the Control Knob clockwise reduces the gas flow from Maximum to the Pre-Set Minimum Setting. Turning between Maximum & Minimum does not actuate the Piezo Igniter. The Control Valve can only be turned on to the Pilot setting by depressing the control knob & turning it to the pre-selected pilot position.
- Switching Off.** Press the Control Knob in at the Pilot Position & turn Clockwise to Off.

2.2 - LIGHTING & CONTROLLING THE FIRE – 2 BUTTON HIGH LEVEL CONTROL

Requires Pilot Ignition First.

The side trim positioned High Level Control System is a battery operated gas fire control system that uses push buttons linked to a main control at the base of the fire. This control system is used with an oxy-pilot and has all the safety features required by law and CE approval.

Once the fire is lit by operating the Control behind the Ash Pan Cover the settings can be controlled by the 2 Push Buttons on the upper right side of the Trim.

Using the System

Remove the Ash Pan Cover to get access to the Control Knob used to operate the Fire.

- Switching On/Ignition.** Depress the right control knob & turn counter clockwise. Gas will flow to the Pilot Burner (Pilot Burner is visible looking through the fender, under the flue bed, at the front right hand corner), the integral Piezo Igniter will also give off a high voltage spark & the Pilot Burner will Light. (More than one attempt may have to be made on first lighting.)
Keep the Control Knob depressed for approximately 10 seconds to heat up the Thermocouple.
Turn the Control Knob fully counter clockwise to release gas to the Main Burner.
- Control of Gas Flow Using the Side Trim Push Buttons.** Press the lowest button to gradually reduce the gas flow from Maximum to the Pre-Set Minimum Setting, you will hear the motor turning the control. Keeping the Lower Button depressed will eventually turn the main burner off leaving the pilot alight.
To relight the main burner or increase the heat setting from low, press the Upper Button to achieve settings between low and high. When the fire has reached high the control under the fire will click repeatedly, release the button.
- Switching Off.** Remove the Ash Pan Cover and turn the right Control Knob Clockwise to Off.
- Battery Replacement .** The Batteries should be replaced every season, you will notice they need changing as gradually the Push Buttons cease to operate the Control.
- Changing the Batteries.** Remove the Ash Pan Cover and you will find the Battery Box on the right hand side.
Pull towards the front taking care not to strain the connecting wire. Using a small screw driver remove the screw, slide off the cover and take out the Batteries. Replace with 4 x AA good quality alkaline batteries, operate the Push Buttons to check the Batteries are fitted correctly. Remember to put it back in the same position.

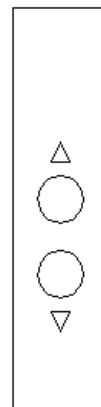

Note: Only Change The Batteries When The Fire Is Cold

2.3 - LIGHTING & CONTROLLING THE FIRE - 3 BUTTON HIGH LEVEL CONTROL

The 3 Button High Level Control Lights the Pilot and Controls the Fire.

The side trim positioned High Level Control System is a battery operated gas fire control system that uses push buttons linked to a main control at the base of the fire. This control system is used with an oxy-pilot and has all the safety features required by law and CE approval.

Note: The Centre Button is both the Ignition and Off Button.

Using the System

- Ignition.** Simultaneously press and hold the Centre Button until a short acoustic signal confirms that the sequence has begun, then release the buttons. Continuous audible signals confirm that ignition is in progress.
When pilot ignition is confirmed the motor will open the valve to maximum flame height – this takes about 30 seconds. When the fire is first operated and on occasions when the fire has not been used for some time the Pilot may not light after pressing the Centre Ignition Button even though the acoustic sound may have been heard. On these occasions it may be necessary to repeat the sequence a number of times to light the pilot. This is quite normal.
- Flame Height Adjustment.** Press the bottom down arrow button until the flame height is at the desired position.
If you try to go beyond the preset low flame minimum height the fire will turn off leaving the pilot burner alight (This is the standby position). You will learn from experience the minimum preset flame height.
- Relighting the Fire.** To relight the fire from the standby position, or to increase the flame height from low flame, press the top up arrow.
Please note that you can have the flame height anywhere between maximum and preset low.
For fine adjustment simply tap the up or down arrows.
- Switching Off.** Press the centre button.



- e. Battery Replacement.** The Batteries should be replaced every season, you will notice they need changing as gradually the Push Buttons cease to operate the Control.
- f. Changing the Receiver Batteries.** Remove the Ash Pan Cover and you will find the Battery Box on the right hand side. Pull towards the front taking care not to strain the connecting wire. Using a small screw driver remove the screw, slide off the cover and take out the Batteries. Replace with 4 x AA good quality alkaline batteries, operate the Push Buttons to check the Batteries are fitted correctly. Remember to put it back in the same position.

Note: Only Change The Batteries When The Fire Is Cold

2.4 - LIGHTING & CONTROLLING THE FIRE - THERMATRONIC RF CONTROL

The Thermatronic Control System is a battery operated gas fire control system that uses a microprocessor to provide the working sequences needed by the fire, and when used with an oxy-pilot has all the safety features required by law and CE approval. Commands are accepted by the microprocessor when buttons are pressed. An audible beep means that the command is received, and the push button should immediately be released.

Using the System

Control can only be achieved if the Handset is pointed at the Fire.
The red light will flash each time you press the Handset.

- a. Ignition.** Simultaneously press and hold the red button and the right upper button (linked by line) until a short acoustic signal confirms that the sequence has begun, then release the buttons. Continuous audible signals confirm that ignition is in progress. When pilot ignition is confirmed the motor will open the valve to maximum flame height – this takes about 30 seconds.
- b. Flame Height Adjustment.** Press the small flame button until the flame height is at the desired position. If you try to go beyond the preset low flame minimum height the main burner will turn off leaving the pilot burner alight (this is the standby position). You will learn from experience the preset low flame minimum height.
- c. Relighting the Fire.** To relight the fire from the standby position, or to increase the flame height from low flame press and hold the large flame button until the desired flame height is achieved. Please note that you can have the flame height anywhere between maximum and preset low. For fine adjustment simply tap the small or large flame buttons.
- d. Switching Off.** Press the red/off button on the Handset.



2.5 - GENERAL

- a.** Battery replacement is recommended at the beginning of each heating season, or when an acoustic error message sounds during ignition.
- b.** Error Message – Long signals (0.8 second tone – 0.2 second break) during ignition – probable cause - batteries in electronic receiver box are nearly discharged.
- c.** Error Message – 5 second continuous tone – probable cause – cable disconnected or on/off switch on valve is in off position.
- d.** Batteries - Electronic Receiver Box - 4 x AA good quality alkaline - Handset - 1 x PP3 good quality alkaline.
- e.** To change the Handset battery slide open the plastic panel on the back of the Handset.
- f.** To change the Receiver Batteries remove the Ash Pan Cover and locate the electronic receiver box, underneath the fire on the right hand side. Pull towards the front taking care not to strain the connecting wire. Slide open the plastic cover to gain access to the battery compartment. Replace with 4 x AA good quality alkaline batteries, operate the Push Buttons to check the Batteries are fitted correctly. Remember to put it back in the same position.

Note: Only Change The Batteries When The Fire Is Cold

2.6 - RESETTING THE MERTIK MAXITROL LOGIC CIRCUITS *ONLY APPLIES TO THE THERMATRONIC HAND HELD RADIO FREQUENCY CONTROL*

Basic Reset - It sometimes happens that (such as when the handset buttons are pressed out of sequence) the fire stops working because the logic circuits get confused and need to be reset.

To do this, simply remove the 4 x AA batteries from the Receiver Box (see section 2.5f above), wait for 1 minute and then refit the batteries. Wait for another minute and then point the handset at the fire and press the red/off button. Wait for another minute and then start the fire as normal. If the fire does not start repeat the resetting procedure. If the fire still does not work a Full Reset can be tried.

Full Reset - If you obtain a new handset the control system will need to learn the handset's unique code via a Full Reset. Also, if the fire is not working and the Basic Reset has not worked a Full Reset can be carried out:

Remove the Ash Pan Cover and locate the electronic Receiver Box.

Locate the Reset Hole on the side of the Receiver and using a pen press and hold in the Reset button until you hear two beeps. The first beep is short and the second beep is long. After the second beep release the Reset Button.

Now on the Handset, within the next 20 seconds press and hold the Small Flame Button until you hear two additional short beeps confirming the code is set in the Receiver.

If you hear one long beep the Code as not been set so repeat the procedure.

If after carrying out the above procedure the situation is not corrected it will be necessary to contact your Installer.

Note: For the Installation/Service Engineer - Resetting of the Handset & Control System is also covered in Section 21.1

2.7.- COAL-COKE EFFECT LEVER

Note : This Feature is **not used** on all Propane Models.

The Natural Gas Coal Fire Model is fitted with a control lever to enable different flame effects to be created. With the lever pushed-in the flames will be quite yellow replicating a Coal Fire Flame Effect. With the lever pulled-out the flames will be more blue replicating a Coke Fire Flame Effect.

- a. Remove the Ash Pan and at the upper centre of the opening you will see the black Coal-Coke Lever. Push the lever in for the Coal Effect setting, pull the lever out for the Coke Effect setting.

! IMPORTANT ! On the Coal Setting, the Yellow Flames may cause some sooty deposits to form and to reduce this we recommend changing to the hottest Coke Setting.

! TIP ! The Coke Fire Flame Effect setting provides the hottest and most efficient Heat Output for the Fire.

3. - CLEANING THE FIRE

- a. Allow to cool before cleaning.
- b. The outer surfaces of the fire can be cleaned with a damp cloth and lightly polished with a duster, do **not** use abrasive cleaners. For Stainless Steel finishes we recommend a small amount of Baby Oil.
- c. The glass can be cleaned with care using clean water, however take care not to disturb the fuel bed when cleaning on the inside.
If stubborn marks persist use a purpose produced ceramic hob cleaner and wipe off after cleaning with a soft dry cloth.

4. - SERVICING

- a. The fire should be Serviced Annually in accordance with the Gas Safety & Uses Regulations.
- b. This fire contains no User Serviceable Parts apart from the batteries which are only used with the High Level and Thermatronic Control System options.
- c. Servicing must be carried out by a Registered Installer.
- d. For Servicing or Spare Parts contact your Installer quoting the Fire Name, Model and Serial Number, which can be found on the Data Badge. To find the Data Badge/Plate; with the fire cool remove the Ash Pan Cover, the Data Badge can be found at the base next to the Control Knob.
- e. In the event that the fire shuts down due to any reason, attempt to restart it. If there is a continuing problem, call in a properly qualified specialist engineer.
- f. The Matrix in the fire is a Moulded Ceramic Fibre component incorporating Silicone Binders and you may notice that it develops cracks during operation. This is natural shrinkage caused by exposure to high temperatures and is quite normal for the material and will in no way affect the operation of the fire.

THE ENERGIS SLIMLINE VISTA+ INSTALLATION & SERVICING INSTRUCTIONS

RECORD DATA TO BE COMPLETED & KEPT BY USER:

PLACE OF PURCHASE DATE

ADDRESS & TEL. NO.
.....
.....

APPLIANCE SERIAL NO.

INSTALLED BY GAS SAFE REG. NO.

SITE SURVEYING - SURVEYING THE PROPERTY PRIOR TO INSTALLATION

THE FOLLOWING ARE RECOMMENDATIONS FOR SURVEYING AND ARE IN ADDITION TO THE REQUIREMENTS OF THESE INSTRUCTIONS, NATIONAL STANDARDS AND BUILDING REGULATION REQUIREMENTS.

The following recommendations should be considered to try to avoid problems that will result in issues after the fire has been fitted.

- a)** Downdraught can be a major problem which may result in return visits with problems after the fire has been fitted so:
 - i) Check the geographical position of the property taking account of any known downdraught issues in the area.
 - ii) Check any existing Properties for any special chimney terminals that would indicate downdraught problems.
 - iii) Check any existing fires for signs of downdraught, e.g. discolouration above the fire.
 - iv) Ask the Customer if they ever suffer from wind blowing down the chimney.
- b)** With Pre-cast flues check the following:
 - i) Any signs of walls over heated both on adjoining walls and upstairs. Bring any issues found to the attention of the Customer.
 - ii) Check for any Cracks in the wall above the fire.
 - ii) Check the soundness of any connecting tubes in the loft area.
- c)** Take account of the type, size and height of the chimney when considering the suitability of the fire being considered.
For instance if the chimney is quite large or high a higher efficient fire may be more suitable or flue lining may need consideration.
- d)** Take account of the fire previously fitted and enquire if the heat output will be sufficient for the room size and heat requirements of the room.
- e)** Check the condition and soundness of the chimney before proceeding with the installation or any building work.
- f)** Check any wall decoration around the fire for its suitability for withstanding temperatures especially with high efficient fires.
- g)** Take account of the size of the room any large windows ensuring that the fire being considered will provide sufficient heat.
Make the Customer aware if you feel a different type of fire would be more suitable.
- h)** Check if the suitability of the Control being considered will meet the Customers requirements, specifically with people with arthritic problems. Consider if a High level or Remote Control System would be more suitable and make the Customer aware of the advantages.
- i)** If an high efficient fire is being considered into an existing fire surround determine if it is a suitable material, for example some micro marble surrounds are prone to discolouration.
Check for any signs of discolouration and make the Customer aware of the possible problem.
The fire must only be installed into a fire surround with a (150centigrade rating).
- j)** Carry out a gas soundness check on the current installation prior to Installation.

We would recommend that if you come across known problems in your area that you add them to the above survey points for future reference.

If you are unsure of any aspect of the Installation seek expert advice.

5. - INSTALLATION REQUIREMENTS

THIS APPLIANCE MUST BE INSTALLED AND SERVICED BY A PROPERLY QUALIFIED, (IN ACCORDANCE WITH LOCAL & NATIONAL CODES), INSTALLATION ENGINEER.

It is the Law in the UK that All gas appliances are installed by a competent person in accordance with the GAS SAFETY (INSTALLATION AND USE) REGULATIONS 1998 (As amended), the relevant British Standards for Installation work, Building Regulations, Codes of Practice and these Instructions. In the UK a Registered Installer is deemed competent. In the Republic of Ireland, all Irish Standards, Local Codes and Bord Gais recommendations should be adhered to.

The Installation should also be carried out in accordance with the following where relevant:

1. BS5871 Part 2 2. BS5440 Parts 1 & 2 3. BS6461 Parts 1 & 2 4. BS6891 5. BS8303 6. BS EN 1856 7. BS715
Building Regulations and Standards issued as relevant by the Department of the Environment or the Scottish Development Department.

In the Republic of Ireland Installation should be carried out in accordance with IS813, ICP3, IS327, Building Regulations, Codes of Practice, these Manufacturers Instructions and any Rules In Force.

Particular Reference should be made to the Ventilation Requirements, for the UK this Appliance would not normally require any additional purpose provided ventilation, for the Republic of Ireland ventilation should be in accordance with IS813 Domestic Gas Installations.

Failure to comply with the above could leave the Installer Liable to Prosecution and Invalidate the Warranty.

IMPORTANT

BEFORE PROCEEDING WITH THE INSTALLATION READ THESE INSTRUCTIONS CAREFULLY. THESE INSTRUCTIONS SHOULD BE LEFT WITH THE USER FOR SAFE KEEPING AND FUTURE SERVICING. PRIOR TO INSTALLATION ENSURE THAT THE GAS TYPE AND PRESSURE ARE AS STATED ON THE APPLIANCE DATA BADGE.

6. - APPLIANCE DATA

- a. Gas Type: See Data Plate (Natural Gas at 20mbar or Propane at 37mbar).
- b. Burner Pressure: Natural Gas 18.0mbar cold. Propane 35.8mbar cold.
- c. Control System: Manual or High Level (Push Button) or Thermatronic (Fully Sequential) Control System operated by Handset pointed at Receiver.
- d. Fire Safety: Oxygen Depletion & Flame Failure Device.
- e. Ignition: Manual-Integral Piezo Igniter, High Level-Integral Piezo Igniter, Thermatronic-Full Sequential Control.
- f. Inlet Connection: 8mm Compression Fitting to Gas Isolation Elbow.
- g. Category: I2H & I3P.
- h. Injector: Natural Gas (G20) - 480 Multi hole. Propane (G31) - 230 Single hole.
- i. Heat Input: High: Natural Gas (G20) - 6.95kW Gross (6.26kW Nett). Propane (G31) - 6.5kW Gross (6.0kW Nett).
- j. Heat Input: Low: Natural Gas (G20) - 2.66kW Gross (2.4kW Nett). Propane (G31) - 2.17Kw Gross (2.0kW Nett).
- k. Efficiency Class: 1. The Efficiency of this appliance has been measured as specified in BS7977-1:2009+A1 2013 and the results obtained were Natural Gas 66.4% Gross (73.7% Nett), Propane 66.4% Gross (72.1% Nett). The test data has been certified by BSi Group (0558) and can be used in the UK Government's Standard Assessment Procedure (SAP) for Energy Rating of Dwellings.
- l. Heat Output: High: Natural Gas (G20) - 4.61kW. Propane (G31) - 4.32kW
- m. Heat Output: Low: Natural Gas (G20) - 1.5kW. Propane (G31) - 1.2kW
- n. Pilot ODS Type: Natural Gas (G20) - P448 or NG9033 or NG9090. Propane (G31) - P449 or LPG9025.
- o. Nitrous Oxide (NOx): 130mg/kWh.

7a. - APPLIANCE DIMENSIONS

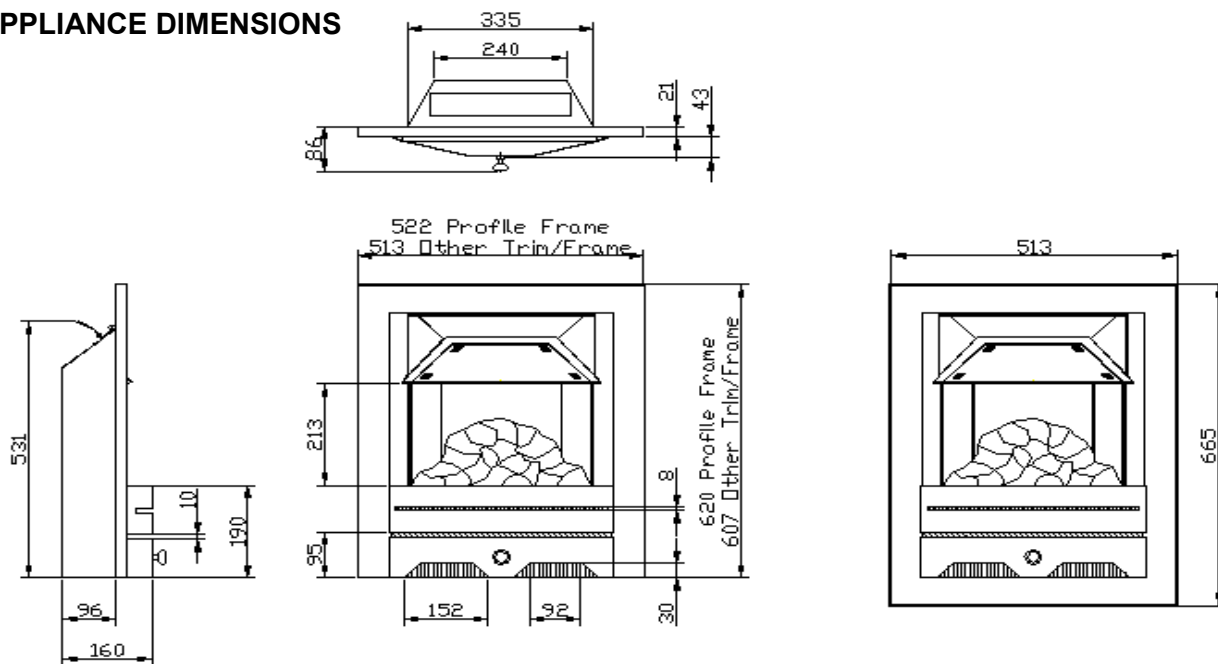

With 3 sided frame for fireplace use.

Additional detail for "Hole in the Wall" frames

Designs may vary; the diagram above is to show important dimensions

7b. - FRAME & TRIM DIMENSIONS (Other Optional Trim Styles)

The following Frames and Trim are supplied separately with their own Instructions.

The Arc Trim and Cast Trim are supplied with fixing brackets.

The Arc Trim (Fireplace Version) can be installed with or without the Arc Frame (Fireplace Version).

The Arc Trim (Hole in Wall Version) is for Wall Mounted fire applications and can be used with or without the Arc Frame (Hole in the Wall Version).

Also See Flat Area Requirements For Each Trim Type

Art Frame (Hole in Wall Version)

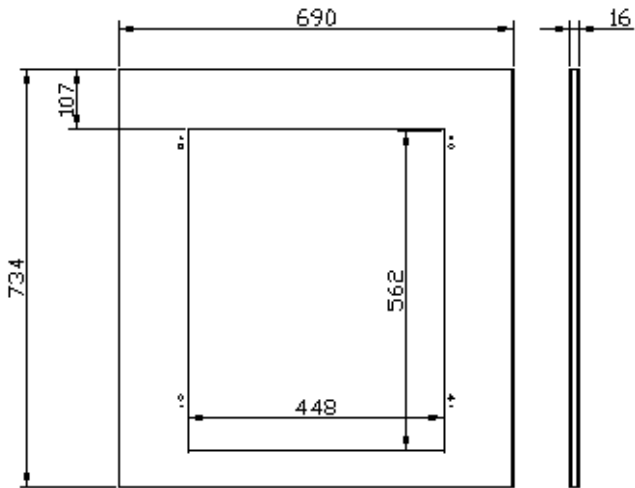

Arc Frame (Fireplace Version)

Minimum Flat Area = 695mm(h) by 675mm(w)

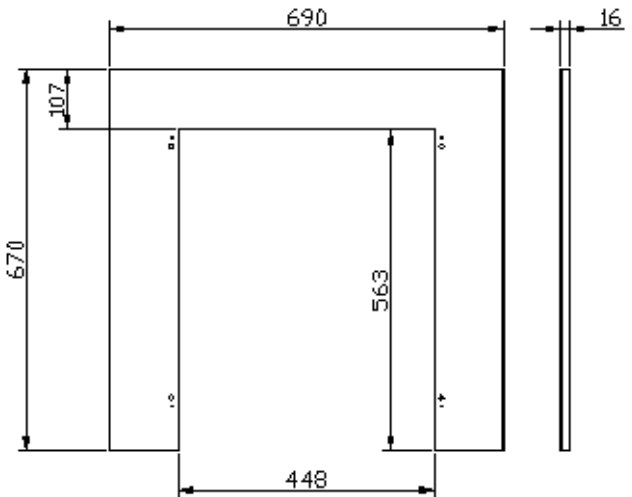

Arc Trim for use with or without the Arc Frame (Hole in Wall Version)

Minimum Flat Area = 545mm(h) by 615mm(w)

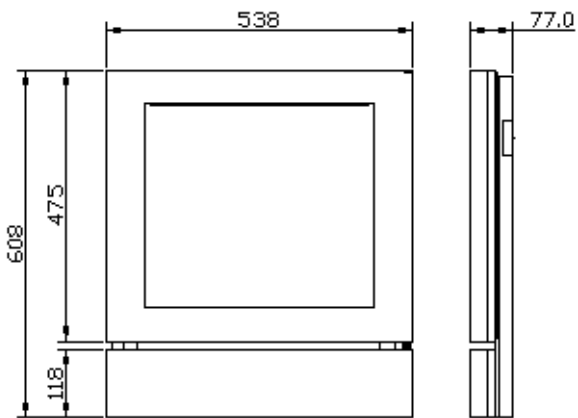

Arc Trim for use with or without the Arc Frame (Fireplace Version)

Minimum Flat Area = 545mm(h) by 615mm(w)

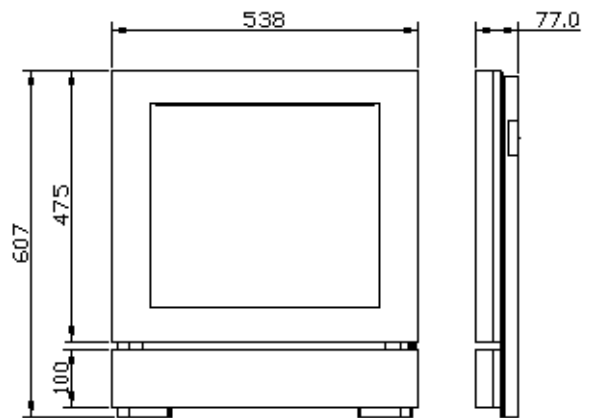

Cast Trim for Hearth/Fireplace Installations

Minimum Flat Area = 630mm (h) by 535mm(w)

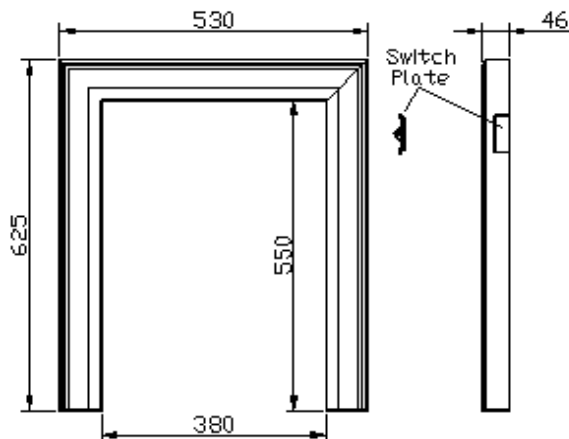

8. - FRET REQUIREMENTS

!IMPORTANT NOTE! THE FRET CAN AFFECT THE SAFE OPERATION OF THE FIRE

These checks MUST be made before selecting a suitable Fret

- The Important Minimum Open Area's (for airflow) of the Fret are shown in the diagram, with the minimum dimensions .
- The Minimum Open Area at the base of the Ash Pan Cover is 5200mm sq equally shared between two openings, they must be at the base of the Ash Pan Cover.
- The Minimum Open Area in the Fender area (above Ash Pan Cover) is 7500mm sq which can be provided through one or more slots.
- The correct height to the Upper most part of the Fret must be 190mm, to align with the Fuel Bed.
- The opening for the Ash Pan Cover area must be 85mm minimum height to allow access for operation of the Controls.
- The Fret will have to be curved at the back and must be checked to ensure it does not foul the Matrix of the Fuel Bed. It should also touch the Trim.

TOTAL OPEN AREA AT FENDER = 7500mm sq
TOTAL OPEN AREA AT ASHPAN = 5200mm sq

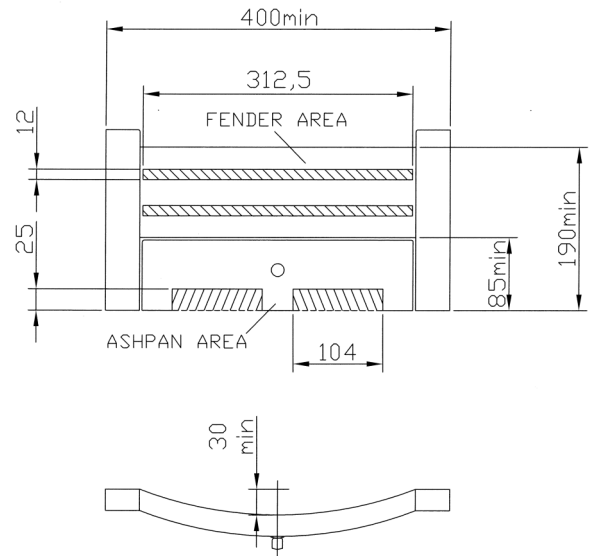

THE SHADED AREAS ARE THE MINIMUM SIZED OPENINGS

9. - FLUE REQUIREMENTS

These checks MUST be made before constructing the Builders Opening

The Appliance is suitable for Installation into the following types of Flue:

- Conventional Stone/Brick Built Flue (Class 1) with a minimum cross sectional dimension of 175mm (7") with a minimum effective height of 3 meters.
- The flue **MUST** be free of any obstructions. Any dampers or restrictors **MUST** be removed. Some dampers are impractical to be removed; therefore they **MUST** be fixed in some way in the **OPEN** position.
- The chimney/flue should be swept if it has been used for solid fuel.
- A Flue Lined with a 5" Flexible Flue Liner connected to a Register Plate fitted and sealed at the top of the Builders Opening with a minimum effective height of 3 meters.
- A Pre-cast Flue with Starter Blocks conforming to BS1289: 1975, 1986, or 1989 or BS EN1858 and having a minimum cross sectional flue of 198mm by 67mm and Starter Blocks providing 115mm deep by 304mm wide with a minimum height of 555mm. No part of the Pre-cast Flue must be less than 63mm.
- The Fire may be used in conjunction with a Fully Sealed Rebated 150C rated or Equivalent Purpose Built Fire Surround.
- Any Pre-Cast Flue must be Sound and Free from Obstructions (Mortar Fangs or Protrusions into the Flue Way) and have an effective height of over 3 meters.
- For Pre-cast Flues - ensure the walls are dry lined over the route of the flue and no dabs or battens are in direct contact with the flue blocks otherwise wall cracking will occur as detailed in BS 5440 Pt 1 2008.
- A Purpose Designed Flue Box to BS715 fitted with a 5" twin walled flue with a minimum effect height of 3 meters to BS EN 1856. Details are available from your authorised supplier.
- Ensure that only one fireplace is served by the flue system.
- Ensure that the chimney/flue is continuous from inlet to termination.
- Ensure that the chimney/flue is structurally sound, so that combustion products do NOT come into contact with combustible materials outside the chimney.
- CHECK FLUE PULL.** Apply a smoke match or smoke generator to the flue opening at hearth level and observe smoke. If there is a definite flow into the flue aperture, proceed with installation. If there is not a definite flow into the flue aperture, preheat the flue for approximately 10 minutes and re-test. If there is not a definite flow towards the flue aperture the flue may need attention. **DO NOT FIT THE APPLIANCE, SEEK EXPERT ADVICE.**

10. - VENTILATION

- No additional purpose provided ventilation is normally required for the fire when installed in the UK; however this **must** be confirmed by the Spillage Test, see Section 18.2.
- For other Countries refer to National Regulations and Local Codes.
- This appliance is fitted with an oxygen depletion sensing system, which automatically shuts off the gas supply to the fire if the oxygen level in the room is depleted, due to lack of primary air, or obstructed flue that would lead to incomplete combustion of the gas. It **must not** be tampered with and only replaced with a genuine Nu-Flame ODS Pilot.

11. - GAS SUPPLY

It Is Recommended to Check The Next Section as Building Work May Affect the Gas Supply Routing.

- a. Carry out a gas soundness test before working on the gas supply.
- b. Gas supply provision should be made in accordance with the latest Gas Safety (Installation and Use) Regulations as amended.
- c. Confirm that the fire has been supplied for the correct gas to be used by checking the Data Badge in the base of the fire.
- d. A route for a concealed gas supply is provided through a hole in the rear of the fire, at a position of 95mm to the left of the centre of the fire and 49mm up from the base of the Fireplace/Builders opening. An isolation elbow is provided at the control inlet. Your 8mm gas supply pipe needs to protrude through the back of the convector box by approximately 105mm to achieve a neat connection onto the back of the isolator elbow on the burner. (This applies to All Control Options.)
- e. Where the gas supply passes through walls, floors, voids, concrete and wall cavities the supply should be sleeved.
- f. Determine the gas supply pipe size required taking into account any other gas appliances.
- g. Determine where the gas supply pipe needs to terminate and fit the 8mm compression isolation/pressure test elbow provided.
- h. In common with all other gas appliances, dirt and debris in the gas system can block the valve and gas injectors on this appliance, and faults caused by this are not covered by the guarantee.
Therefore it is important that all gas pipes **must** be purged of both air and debris.
- i. If you suspect that there may still be dirt and/or debris in the gas system, fit a filter in the pipeline, before the gas isolation/pressure test elbow.
- J. Do **not** use jointing compound on any compression fittings on the fire. The use of jointing compound on the compression joints on this appliance will possibly invalidate the guarantee, as it can get into the control mechanism and cause a malfunction.
- k. Seal off the isolation/pressure test elbow and check all gas connections for gas soundness before proceeding to fit the fire.

! IMPORTANT NOTE ! Always reseal the pressure test point and check that it is gas tight. (This accounts for a lot of recalls.)

The Installation Application Options Are:

Sections 12 - 15 are for the various Installation Applications - Only one will apply.

! IMPORTANT NOTE ! The chosen installation should have been predetermined and arranged before installing the fire.

Ensure you refer to the section relevant to your requirement.

- 12.0 Installation into a Class 1 or Lined Flue with a 150°C rated Fire Surround fitted into a Suitable Fireplace Opening or 16” Chairbrick.
- 13.0 Installation into a Pre-cast Flue Fireplace. (Rebated Fire Surround Rated 150°C or Purpose Built Surround Extension.)
- 14.0 Installation into a BS 715 Shallow Flue Box with Twin Wall 5”Flue, False Chimney Breast with either a 150°C rated Fire Surround or part way up the wall as a Hole in the Wall Installation with Slips & Shelf.
- 15.0 Installation into a Hole in the Wall application with a Class 1 or Lined Flue requiring a Purpose made Builders Opening.

12. CLASS 1 OR LINED FLUE FIRE SURROUND APPLICATION

FIREPLACE CONSTRUCTION

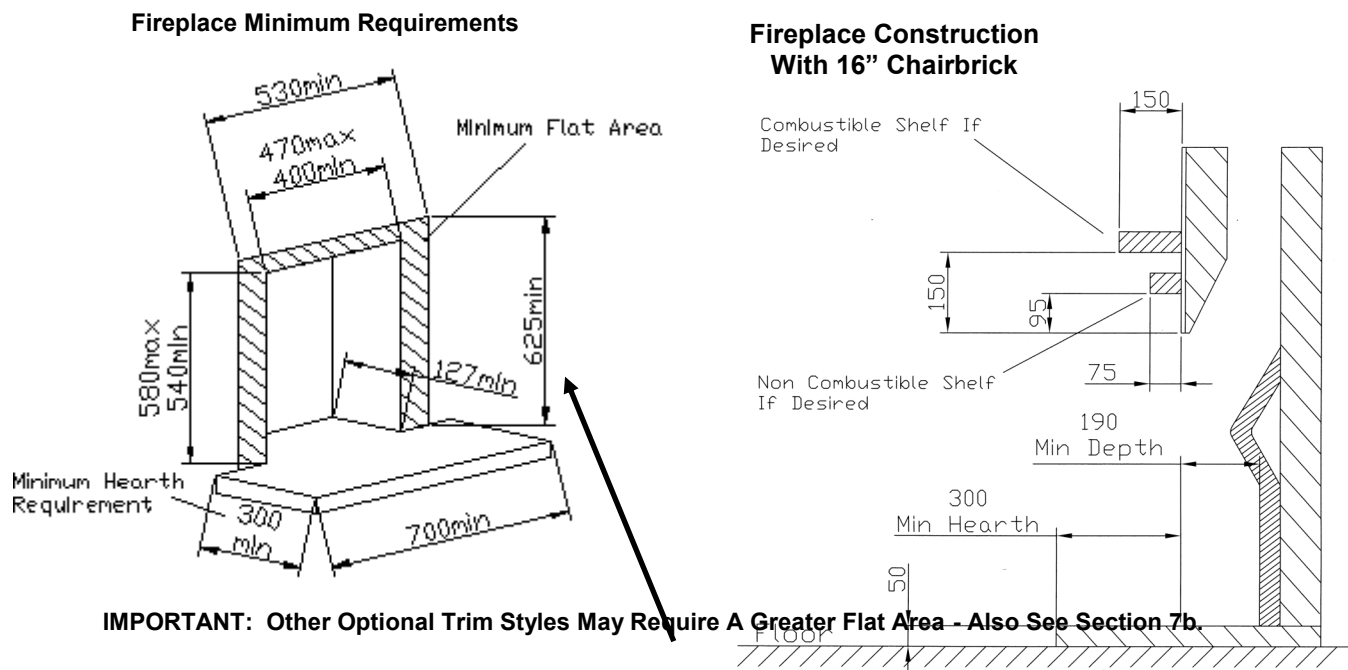

There must be no combustible materials inside the fireplace opening.

12.2 - FIRE SURROUND REQUIREMENTS (See diagram in Section 12.1)

- If the Fire is to be fitted into a purpose made Fire Surround it must have a temperature rating of 150°C.
- Where the depth available is greater than 127mm the minimum width can be reduced correspondingly to a minimum of 350mm.
- Where the fire is to be fitted into an existing 16" chairbrick a depth of 190mm is required to allow sufficient volume for Debris, if sufficient depth is not available the rear of the Chairbrick should be removed or extra depth added to the front.
- The Fire requires a non-combustible hearth of at least 12mm thick.
- The surface of the hearth must stand at least 50mm above the floor and level with the fireplace opening.
- The hearth must project at least 300mm in front of the fireplace opening and 150mm either side (700mm minimum hearth width).
- The base of the fireplace must be flat, level and square to the face of the fireplace opening.
- The Surround must cater for a minimum flat surface around the Fireplace Opening allowing 625mm high by 530mm wide. This is essential in order to achieve a good seal between the face of the surround and the sealing flanges of the fire.
- The Fire Surround must be fully sealed to the Fireplace Opening to ensure a good flue seal.
- The Fireplace Opening should have provision for a gas supply through the rear, see Section 11 Gas Supply.
- The High Level and Thermatronic Control Systems are fitted with Electronic Equipment, which is sensitive to dampness and high humidity so it is very **important** that any rendering/building work is allowed to thoroughly dry out before Installation.

! IMPORTANT NOTE ! Dry lined walls – ensure that any air gaps between the back of the plasterboard and wall are sealed around the builders opening or fireplace as this can affect flue pull and wall staining.

12.3 - CLEARANCES TO COMBUSTIBLE MATERIALS AND SHELVES (Ref: Diagram in Section 12.1)

- A **non combustible** shelf can be fitted above the fire and should be positioned at least 95mm above the builders opening. We recommend the depth of the shelf should be a maximum of 75mm as anything deeper will reduce convection air and the efficiency of the fire. For deeper non-combustible shelves they must be raised a further 25mm for every extra 25mm of depth.
- A 150mm **combustible** shelf can be fitted above the fire but must be positioned at least 150mm above the builders opening. For deeper combustible shelves they must be raised a further 25mm for every extra 25mm of depth.
- Any combustible sidewall must be at least 500mm from the inside of the builders/fireplace opening, however with a combustible fire surround it can be 150mm from the inside of the builders/fireplace opening provided it does not protrude more than 150mm and must be increased by 25mm for every extra 25mm of depth.
- With all heating appliances, soft furnishings, decorations and wall coverings may discolour or scorch if placed too close.
- No combustible material, e.g. curtains must be closer than 500mm to the builders opening.
- Any combustible wall claddings (wall paper) must be cut back to a height of 750mm and 300 mm either side of the Fireplace Opening.
- Due to the heat output of The Energis Slimline Vista+ it is **not recommended** to use blown vinyl wall covering around the fire.

NOW PROCEED TO SECTION 16 - FIXING THE FIRE.

13.1 - EXISTING MINIMUM PRE-CAST FLUE FIREPLACE REQUIREMENTS

**13. INSTALLATION INTO A PRE-CAST FLUE
(Rebated Fire Surround Rated 150°C or Purpose Built Surround Extension)
FIREPLACE CONSTRUCTION**

! IMPORTANT NOTE !

THERE ARE NUMERIOUS DIFFERENT SIZES OF PRE-CAST FLUE FIREPLACES AND THE FOLLOWING DETERMINES THE MINIMUM REQUIREMENTS AND THE ADDITIONAL BUILDING WORK REQUIRED.

**Pre-Cast Fireplaces
Minimum Requirements**

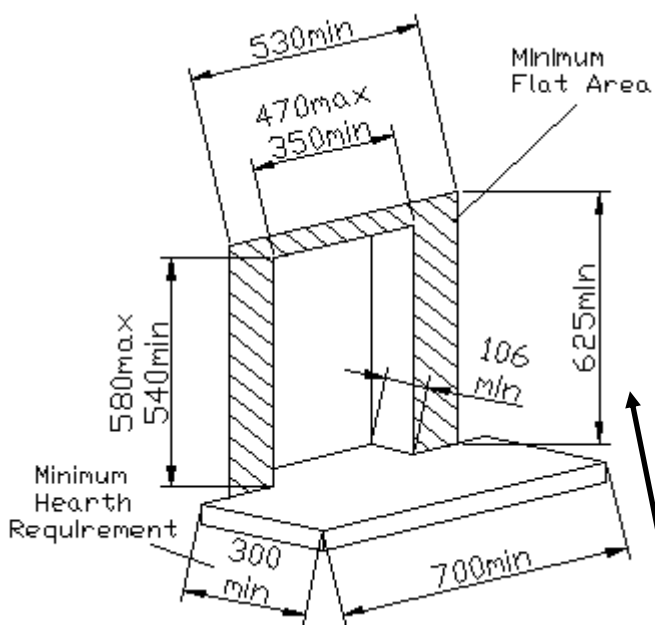

**Pre-Cast Flue Application
Rebated Fire Surround or
Equivalent**

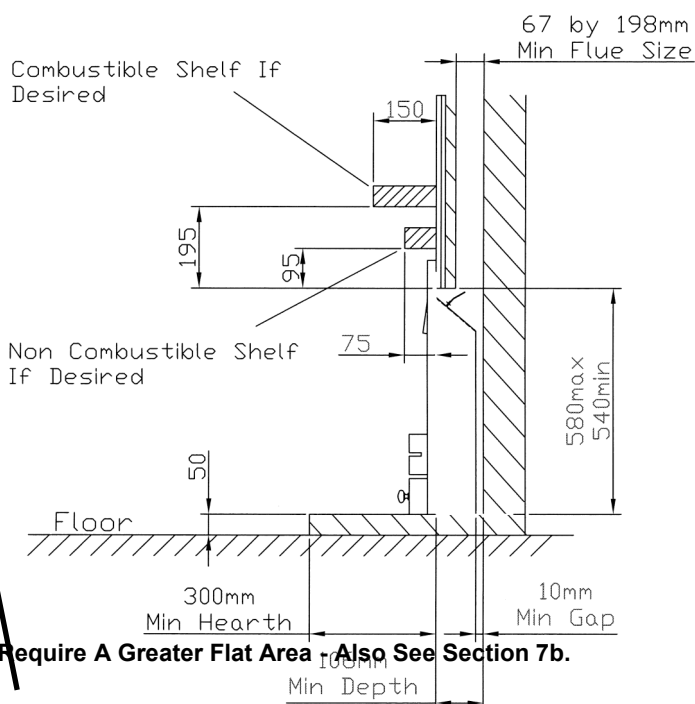

IMPORTANT: Other Optional Trim Styles May Require A Greater Flat Area - Also See Section 7b.

**Pre Cast Flue Fireplace
Depth Construction**

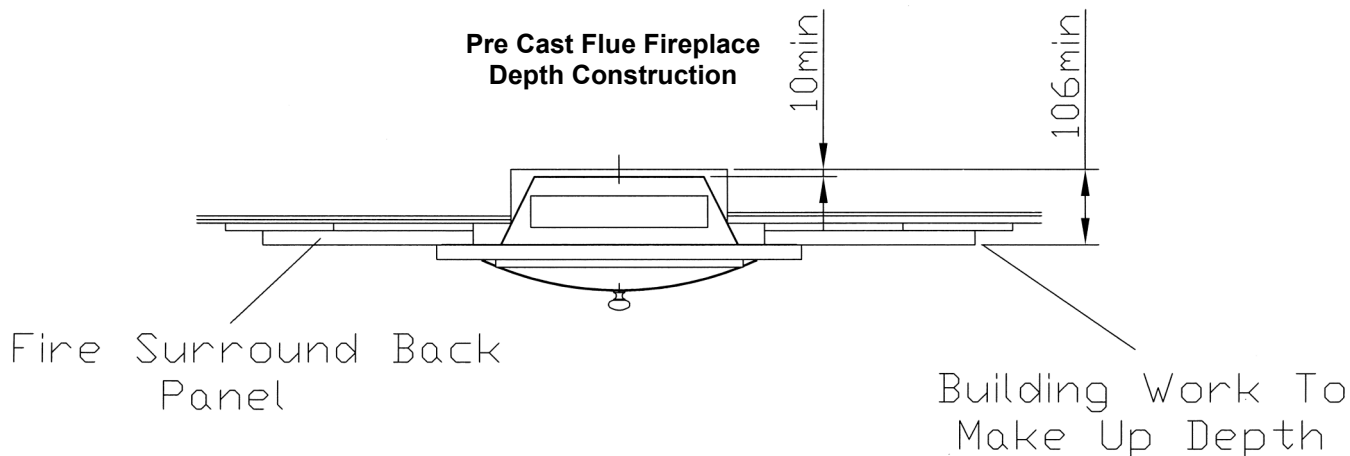

There must be no combustible materials inside the builders opening.

13.2 - FIREPLACE MINIMUM REQUIREMENTS (See diagram in Section 13.1)

With the Majority of Pre-Cast Flue Fireplaces there will be insufficient depth-width and building work with either a Purpose Made Non-Combustible Fire Surround or Rebated Fire Surround Will be Required to Create the Necessary Fireplace Prior to Installation.

Prior to any Building work and to provide adequate flow conditions to the flue, ensure the Minimum Pre-Cast Flue Requirements are available as detailed in a) & b), also make reference to the Diagrams.

- a. The Minimum Pre-cast Flue Size is 67mm deep by 198mm wide with Starter Blocks providing a Minimum Depth of 115mm by 305mm wide. No part of the Flue must be less than 63mm.
- b. The height of the Pre-cast Fireplace opening must be between 540mm and 580mm. If the Starter Blocks have not been provided down to Floor level then building work will be required.
- c. Where the Pre- cast Flue Fireplace with Starter Blocks provide less than the minimum depth of 106mm and width of 305mm a purpose built extension will be required. This Extension must be made of Non Combustible materials and fully sealed to the Existing Fireplace.
- d. The 106mm of depth required caters for a 10mm gap at the rear of the fire to allow for debris build-up.
- e. With the minimum depth it may be necessary to rebate/sink the Eye Bolts to prevent the heads fouling on the back of the fire. See Section 16.2 g.
- f. If the Fire is to be fitted with a purpose made Rebated Fire Surround it must have a temperature rating of 150°C.
- g. The Fire Surround must be fully sealed to the Fireplace Opening to ensure a good flue seal.
- h. The Fire requires a non-combustible hearth of at least 12mm thick.
- i. The surface of the hearth must stand at least 50mm above the floor and level with the fireplace opening.
- j. The hearth must project at least 300mm in front of the fireplace opening and 150mm either side (700mm minimum hearth width).
- k. The base of the fireplace must be flat, level and square to the face of the fireplace opening.
- l. The Surround must cater for a minimum flat surface around the Fireplace Opening allowing 625mm high by 530mm wide. This is essential in order to achieve a good seal between the face of the surround and the sealing flanges of the fire.
- m. The Fireplace Opening should have provision for a gas supply through the rear, see Section 11 Gas Supply.
- n. The High Level and Thermostat control systems are fitted with Electronic Equipment, which is sensitive to dampness and high humidity so it is very **important** that any rendering/building work is allowed to thoroughly dry out before Installation.

! IMPORTANT NOTE ! Dry lined walls – ensure that any air gaps between the back of the plasterboard and wall are sealed around the builders opening or fireplace as this can affect flue pull and wall staining.

Pre-Cast Flues – ensure the walls are dry lined over the route of the flue and no dabs or battens are in direct contact with the flue blocks otherwise wall cracking will occur as detailed in BS 5440 Pt 1 2008.

13.3 - CLEARANCES TO COMBUSTIBLE MATERIALS AND SHELVES (Ref: Diagram in Section 13.1)

- a. A **non-combustible** shelf can be fitted above the fire and should be positioned at least 95mm above the builders opening. We recommend the depth of the shelf should be a maximum of 75mm as anything deeper will reduce convection air and the efficiency of the fire. For deeper non-combustible shelves they must be raised a further 25mm for every extra 25mm of depth.
- b. A 150mm **combustible** shelf can be fitted above the fire but must be positioned at least 150mm above the builders opening. For deeper combustible shelves they must be raised a further 25mm for every extra 25mm of depth.
- c. Any combustible sidewall must be at least 500mm from the inside of the builders/fireplace opening, however with a combustible fire surround it can be 150mm from the inside of the builders/fireplace opening provided it does not protrude more than 150mm and must be increased by 25mm for every extra 25mm of depth.
- d. With all heating appliances, soft furnishings, decorations and wall coverings may discolour or scorch if placed too close.
- e. No combustible material, e.g. curtains must be closer than 500mm to the builders opening.
- f. Any combustible wall claddings (wall paper) must be cut back to a height of 750mm and 300 mm either side of the Fireplace Opening.
- g. Due to the heat output of the Energis Slimline Vista+ it is **not recommended** to use blown vinyl wall covering around the fire.

NOW PROCEED TO SECTION 16 - FIXING THE FIRE.

14.1 - FALSE CHIMNEY BREAST CONSTRUCTION

14. BS715 SHALLOW FLUE BOX WITH TWIN WALL 5" FLUE – FALSE CHIMNEY BREAST CONSTRUCTION WITH FIRE SURROUND OR HOLE IN THE WALL APPLICATIONS

BS715 Shallow Flue Box Application

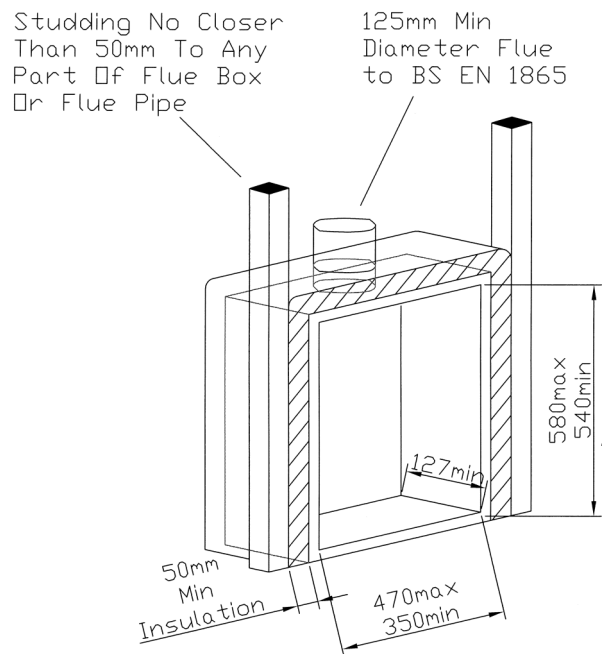

BS715 Flue Box Hole In The Wall Construction

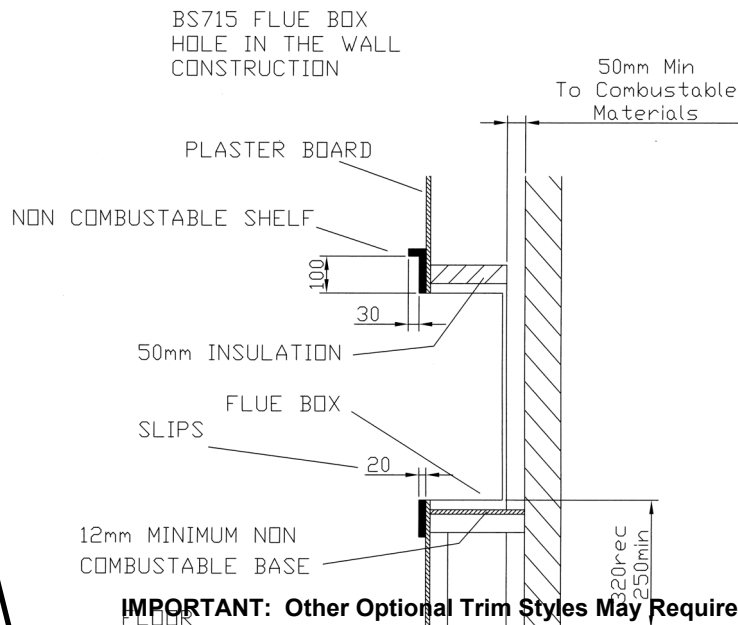

There must be no combustible materials used inside the flue box.

14.2 – BS 715 FLUE BOX BUILT INTO A FALSE CHIMNEY BREAST WITH FIRE SURROUND OR HOLE IN THE WALL INSTALLATION WITH REQUIREMENTS (See diagrams above).

A BS 715 Flue Box can be built into a false chimney breast and installed at floor level with a suitable Fire Surround.

or
The Fire can be Built-In part way up the wall to create a Hole in the Wall Installation, however it is essential to use marble, slate or stone slips, fitted around the builders opening. The slips must have a temperature rating of 150°C and be 20mm (min) thick by 100mm (min) wide.

In order to direct the flow of heated air away from the wall we recommend that a non combustible shelf (lip) is fitted above the top slip, protruding 30mm – see diagram.

For Hole in the Wall fires it is recommended that a means, (tactile separator/shelf or guard) is provided to give abrupt warning to a person moving inadvertently towards the fire.

- a. A suitable BS715 Shallow Flue Box should be used with the minimum dimensions quoted above.
- b. The base of the flue box must be level and square to the face of the fireplace opening.
- c. The Flue Box must sit on Non Combustible Material of at least 12mm Thick.
- d. The Flue Box can be placed against a Non Combustible wall at the rear, however if the wall is combustible it must be spaced 50mm from the wall.
- e. When building a False Chimney Breast No Combustible materials must be closer than 50mm to the Flue Box.
- f. No Combustible materials must be closer than 50mm to the Flue over its entire route through the Property.
- g. The Flue Box must be Insulated on its top and sides with 50mm thick Non Combustible Fibreglass Insulation or Equivalent.
- h. If plaster board is used in front of the flue box it must be sealed to the box with high temperature Silicone Sealant or an equivalent flexible sealant.
- i. If the Fire is to be fitted into a purpose made Fire Surround it must have a temperature rating of 150°C.
- j. For a Fire Surround the fire requires a non-combustible hearth of at least 12mm thick.
- k. The surface of the hearth must stand at least 50mm above the floor and level with the fireplace opening.
- l. The hearth must project at least 300mm in front of the fireplace opening and 150mm either side (700mm minimum hearth width).
- m. The Surround must cater for a minimum flat surface around the Fireplace Opening allowing 625mm high by 530mm wide. This is essential in order to achieve a good seal between the face of the surround and the sealing flanges of the fire.
- n. The Fire Surround must be fully sealed to the Fireplace Opening to ensure a good flue seal.
- o. In order to direct the flow of heated air away from the wall we recommend that a non combustible shelf (lip) is fitted above the top slip, protruding 30mm – see diagram in Section 14.1 on previous page.
- p. There must be a flat surface around the opening of sufficient area to enable the slips to be securely fitted. The slips should be fitted to the wall in such a way that they form a seal to stop air from the room being drawn behind the slips into the False Chimney Breast. We recommend a high temperature silicon sealant.
- q. The **recommended** height for the base of the Builders Opening is 320mm above floor level. The **minimum** height for the base of the Builders Opening is 250mm above floor level.
- r. The Fireplace Opening should have provision for a gas supply through the rear, see Section 11 Gas Supply.

- s. The High Level and Thermatronic control systems are fitted with Electronic Equipment, which is sensitive to dampness and high humidity so it is very **important** that any rendering/building work is allowed to thoroughly dry out before Installation.

! IMPORTANT NOTE ! Do not forget to take account of the difference in height of the base of the Flue Box when mounting the box on the floor; it must be level with the Hearth.

**14.3 - CLEARANCES TO COMBUSTIBLE MATERIALS AND SHELVES (Ref: Diagram on Previous Page)
The Requirement for Shelves for Hole in the Wall Installations is Detailed in the Above Section.**

- a. For Fire Surrounds a **non combustible** shelf can be fitted above the fire and should be positioned at least 95mm above the builders opening. We recommend the depth of the shelf should be a maximum of 75mm as anything deeper will reduce convection air and the efficiency of the fire. For deeper non-combustible shelves they must be raised a further 25mm for every extra 25mm of depth.
- b. For Fire Surrounds a 150mm **combustible** shelf can be fitted above the fire but must be positioned at least 195mm above the builders opening. For deeper combustible shelves they must be raised a further 25mm for every extra 25mm of depth.
- c. Any combustible sidewall must be at least 500mm from the inside of the builders/fireplace opening, however with a combustible fire surround it can be 150mm from the inside of the builders/fireplace opening provided it does not protrude more than 150mm and this must be increased by 25mm for every extra 25mm of depth.
- d. With all heating appliances, soft furnishings, decorations and wall coverings may discolour or scorch if placed too close.
- e. No combustible material, e.g. curtains must be closer than 500mm to the builders opening.
- f. Any combustible wall claddings (wall paper) must be cut back to a height of 750mm and 300 mm either side of the Fireplace Opening.
- g. Due to the heat output of the Energis Slimline Vista+ it is **not recommended** to use blown vinyl wall covering around the fire.

NOW PROCEED TO SECTION 16 - FIXING THE FIRE.

15.1 - SLIPS & WALL COVERINGS

15. HOLE IN THE WALL APPLICATIONS INTO CLASS 1 or LINED FLUE BUILDERS OPENING

It is essential to use marble, slate or stone slips, fitted around the builders opening. The slips must have a temperature rating of 150°C and be 20mm (min) thick and typically form a border round the opening of 100mm. In order to direct the flow of heated air away from the wall we recommend that a non combustible shelf (lip) is fitted above the top slip, protruding 30mm beyond the front face of the slip – see diagram in Section 15.3 on the following page.

With any form of heating appliance convection air will rise up through the fire carrying particles of dust that will in time result in varying degrees of wall staining. The non-combustible shelf is designed to minimise this by deflecting the airflow away from the wall. However, over time some staining might occur and we therefore suggest not using patterned paper around the fire.

Due to the heat output of the Energis Slimline Vista+ it is **not recommended** to use blown vinyl wall covering around the fire.

Where the Chimney Breast is made of Stone or Slate or other Suitable Non Combustible Material with NO wall coverings then Slips are Not Required but the Dimensions of the Builders Opening must be as shown below and a Flat Surface of at least 65mm must be provided around the opening for sealing.

For Hole in the Wall fires it is recommended that a means (tactile separator/shelf or guard) is provided to give abrupt warning to a person moving inadvertently towards the fire.

15.2 - HOLE IN THE WALL APPLICATION (USING MARBLE SLATE OR STONE SLIPS & SHELF)

IMPORTANT: THE FLAT AREA AROUND THE BUILDERS OPENING WILL NEED TO TAKE ACCOUNT OF BOTH THE TRIM STYLE SEE 7b AND THE CHOSEN WIDTH OF THE SLIPS

Builders Opening for Hole in the Wall application (when using marble, slate or stone slips)

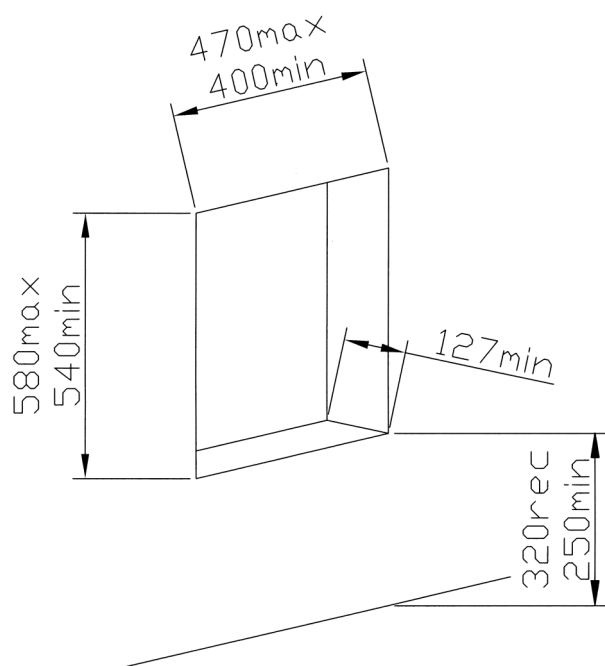

- It is recommended that a qualified builder constructs the builders opening.
- It is recommended that a lintel is fitted above the builders opening.
- The builders opening must be constructed from Non-combustible materials.
- No** combustible materials must be present in the builders opening.
- The base of the builders opening must be flat, level and square to the wall and be at least 12mm thick.
- The builders opening should have provision for a gas supply through the rear, see Section 11 Gas Supply.
- There must be a flat surface around the builders opening of sufficient area to enable the slips to be securely fitted. The slips should be fitted to the wall in such a way that they form a seal to stop air from the room being drawn behind the slips into the builders opening. We recommend a high temperature silicon sealant.
- The **recommended** height for the base of the Builders Opening is 320mm above floor level. The **minimum** height for the base of the Builders Opening is 250mm above floor level.
- High Level and Thermatronic controlled models are fitted with Electronic Equipment, which are sensitive to dampness and high humidity so it is very **important** that any rendering/ building work is allowed to thoroughly dry out before Installation.

IMPORTANT NOTE !

Dry lined walls – ensure that any air gaps between the back of the plasterboard and wall are sealed around the builders opening or fireplace as this can affect flue pull and wall staining.

Hole in the Wall Installation into Class 1 or Lined Flue

15.3 - CLEARANCES TO COMBUSTIBLE MATERIALS

- Any combustible sidewall must be at least 500mm from the inside of the builders/fireplace opening.
- With all heating appliances, soft furnishings, decorations and wall coverings may discolour or scorch if placed too close.
- No combustible material, e.g. curtains must be closer than 500mm to the builders opening.

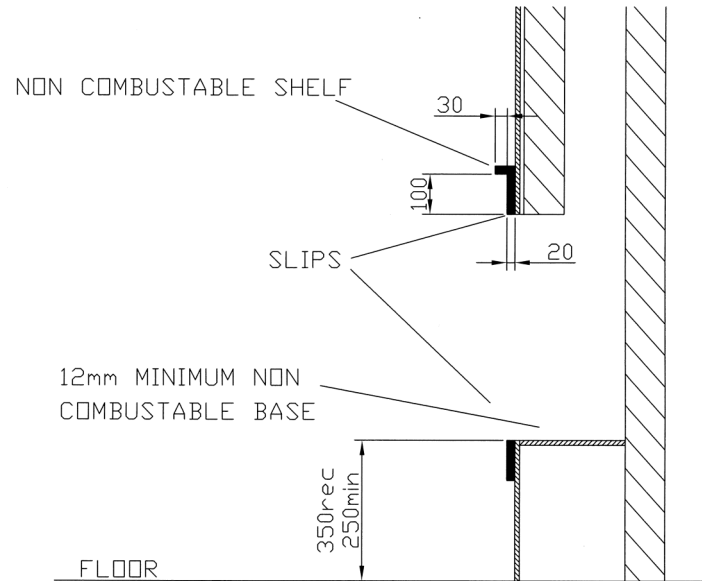

NOW PROCEED TO SECTION 16 - FIXING THE FIRE.

16. FIXING THE FIRE

16.1 - FITTING THE SILICONE SEALING STRIP



It is very important that a good seal is achieved between the back of the Fire's outer frame and the front of the fireplace back panel for safety reasons and to achieve maximum efficiency. Take the self adhesive silicone sealing strip from the fitting kit and neatly apply to the back flanges of the Fire's outer frame, cutting to the appropriate lengths as required. To ensure there is a good seal between the base of the fire and the bottom of the fireplace opening apply a 350mm length of self adhesive silicone sealing strip under the base of the fire at the front edge.

Fit Silicone Sealing Strip to back flanges of outer frame

Fit 350mm length of Silicone Sealing Strip under the base of the fire at the front edge

Note: Where the fire has been ordered with any of the Optional Trims or Frames in Section 7b see the next page for fitting fixing brackets and foam seal. Otherwise proceed to 16.3 Fitting the Fire

16.3 - FITTING THE FIRE - references should be made to the drawings overleaf.

! IMPORTANT NOTE ! TAKE GREAT CARE WHEN WORKING INSIDE THE FIRE NOT TO MARK THE CERAMIC LINING PANELS.

- a. Using a Dust Sheet or equivalent protect the area around the Fire Installation.
- b. Remove the Fire from the box and lay it on its back.
- c. With the High Level and Thermatronic Control Systems remove the Control Heat Shield, which is secured with a single screw at the base of the fire on the left side.
- d. Now remove the Burner/Control Assembly by removing the 2 screws at the front of the fire taking care not to mark the liners. Slide the Burner Assembly forward and if the fire is fitted with the High Level or Thermatronic Control it will also be necessary to carefully slide out the Battery/Receiver Box and, in the case of the Thermatronic Control, carefully pull the Infrared Sensor off its Velcro Pad.
- e. Remove the Debris Plate at the back by removing the 4 screws allowing access through the Debris Opening for fitting the Gas Supply.
- f. There are fixing holes in the front flanges which can be used if there is sufficient strong material for fixing, however we recommend the cable fixing system which is supplied to secure the unit into the fireplace. The cable fixing system will also pull the unit tight back into the fireplace to make a good seal. This is very important to ensure efficient and safe operation of the fire.
- g. There are a number of options for the Cable fixing system in different installation applications therefore please read the options first before proceeding.
 - i. For Builders Opening applications and with reference to the diagram overleaf use the 2 cables supplied; 1 to be used each side of the unit. Working 27mm up from the base of the Builders Opening and at 200mm centres drill the lower holes and then at 455mm up from the base but at 250mm centres drill the upper holes. Secure the 4 Eyebolts supplied with the Raw plugs to the back of the fireplace.
 - ii. For Pre-cast Flue applications where the minimum depth is found it may be necessary to sink/rebate the Eye Bolts to ensure the heads do not foul on the back of the fire.
 - iii. For Chairbrick applications and to prevent the cables fouling on the Knee of the Chairbrick the Upper Eye Bolts should be secured to the side walls of the Chairbrick. Positioned at same height as the standard option above but with the upper eye bolts 100mm in from the front. See Diagrams below and on next page.

IMPORTANT: ENSURE THE MATERIAL THE EYEBOLT/RAWPLUG IS FIXED INTO IS SOLID AND SOUND. If the fixing is not sound the Rawplug/Eyebolt will be pulled out and the fire will not be sealed to the Fireplace Opening.

Note: With the minimum depth fireplace enclosure it may be necessary to sink the Eye Bolt Heads into the Brickwork.

- h. With the Eye Bolts now in position there are 2 cable attachment tabs on the top of the main casing; 1 each side at the rear. Feed a cable outward through each cable attachment point.
- i. Feed the cables through the eyebolts on either side and then through the holes in the back of the fire near the base.
- j. Slide the Fire **part way** into the fireplace (leaving it sticking out approximately 50mm) ensuring the gas supply pipe and isolation/pressure test elbow clears through the Debris Opening in the rear of the Fire.
- k. Slide the Fire fully home ensuring that the sealing strips on the rear of the Fire outer frame stay in position to make a seal against the fireplace back panel. While sliding the unit into the fireplace opening pull on the excess cable.
- l. Locate the supply pipe into the slot in the Debris Opening and replace the Debris Plate.
- m. The Cable Fix Adjuster and Lock Screw can now be fitted onto the cable and tightened up to tension the fire back into the fireplace. The fire should be secure and not liable to movement.

Surplus fixing cable MUST NOT be cut off and must be tucked back through the central hole in the Back of the Fire. This is particularly important with the Electronic Control Systems to keep the cables away from any electronics.
- n. If any of the silicone sealing strips are not compressed and/or if there are gaps they must be filled with a suitable sealant, ideally high temperature silicone or fireclay. Refit the Burner/Controls Assembly with the 2 screws and with the High Level and Thermatronic Systems reconnect the switch wire to its Battery box. Then for the High Level and Thermatronic Control Systems refit the Battery/Receiver Box at the left hand side. Then refit the Heat Shield above the Battery/Receiver Box and secure with the screw removed earlier.

Important: Ensure the Heat Shield has been fitted with the High Level and Thermatronic Control Systems.

- o. Connect the isolation/pressure test elbow to the control valve and with it fully open check the joint for gas soundness.
- p. Check that all gas connections are sound. The appliance has been factory tested; however the connections may have been disturbed in transit or storage.

! TIP ! Ensure the Red Bulb on the Infrared Sensor is facing Forward as this can prevent the Handset from working.

! IMPORTANT NOTE ! Always reseal the pressure test point and check that it is gas tight. (This accounts for a lot of recalls.)

Cable Fixing Positions in a Chairbrick

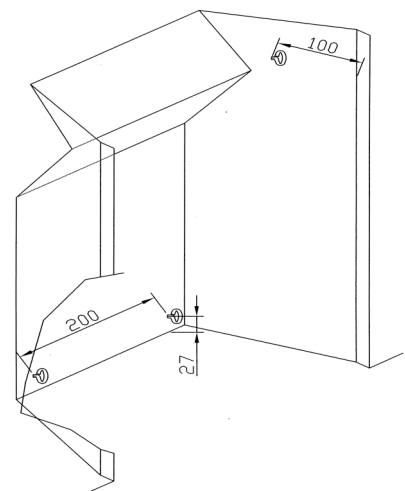

16.2 - OPTIONAL FRAMES, TRIMS AND CAST TRIM

(FITTING FIXING BRACKETS FOR TRIM & FRAMES WITH SILICONE SEALING STRIP)

Identify the Arc Trim or Frame Type below and fit the fixing brackets as described.

Fitting the Fire with either of the Arc Frames (Fireplace or Hole in the Wall Version).

Step 1

Take the Frame and the Silicone Sealing Foam provided and apply it to the rear flange of the Frame as shown.

Note: For the Hole in the Wall Version the foam will be applied all around the Frame.

For the Fireplace Version the foam will just applied around the sides and top.

Ensure the wall/surface is flat and will allow a good seal to be achieved by the sealing foam, any gaps must be sealed.

Important: To ensure the fire operates **Safely** and **Efficiently** the Frame **must** be sealed to the wall/surface.

Step 2

The Frames can now be either screwed directly to the wall through the holes provided or secured with the fire by the Cable Fixing System described in these Instructions for the type of Installation being carried out in the appropriate Section.

We recommend the Cable Fixing method as damage caused by drilling a Fire Surround could result in cracking. Nu-Flame will not accept responsibility for any damage that may occur both during fitting or at a later date.

For Cable fixing first secure the Fire, (with foam attached as described in the previous Section 15.2), to the Frame with the screws provided and then follow the Installation Instructions for the type of Installation being carried out in the appropriate Section.



Arc Trims (Fireplace & Hole in the Wall Versions)

(Fitting Arc Trim fire fixing brackets)

The Fixing Brackets and Screws will be supplied with the Fronts and are the same for both Arc Trim Types

Take the 2 brackets and screws supplied and fix to the fire through the 4 holes, (2 each side), on the top flange as shown.

The Brackets are supplied with slots for adjustment which can be adjusted when the Front is fitted.

Note: The Arc Trim Will Be Fitted Later at 18.3.

Now proceed to 16.3.



Cast Trim

(Fitting Cast Trim fire fixing brackets)

If the Cast Trim is to be fitted to a High Level 2 or 3 Button Model then remove the Switch Plate on the upper right side by removing the single screw.

Step 1

Take the 4 brackets and screws supplied and fix the 2 top brackets through the 4 holes, (2 each side), in the top flange as shown.

The Brackets are supplied with slots for adjustment which can be adjusted when the Trim is fitted.



Step 2

Then take the 2 bottom brackets and locate in the slot and then fix at the bottom left and right corners with the 2 screws supplied, (1 each side), as shown.

Note: The Cast Trim Will Be Fitted Later at 18.3.

Now proceed to 16.3.

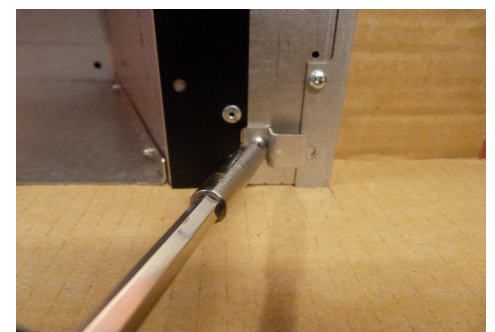

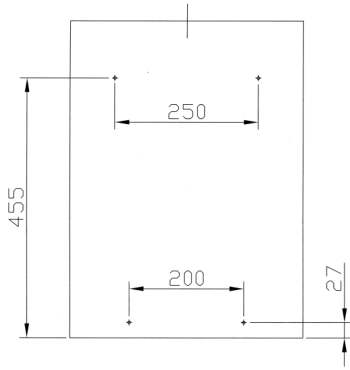

Hole Positions in back of Fireplace Opening

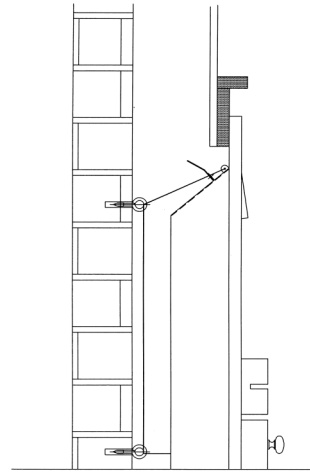

Side View of Cable Fixing System

17. - ARRANGEMENT OF THE FUEL EFFECT

Remove all the Fuel Effect parts, you will see there are 5 different sizes and shapes of Coals some are lettered for identification.

**Health & Safety Advice
Refractory Ceramic Fibre (RCF)**

Advice when working with Fuel Bed Components including Installing, Servicing and Disposal.

The Fuel Effect parts and possible Linings of this fire are made from Refractory Ceramic Fibre (R.C.F.) a Class 2 Carcinogen which is a material designed for this Application. Excessive exposure to these types of materials may cause temporary irritation to eyes, skin and respiratory tract. Therefore take care when handling these articles to ensure dust is kept to a minimum.

It is not necessary to wear protective clothing when handling these articles but we do recommend you follow the normal hygiene rules of not smoking, eating or drinking in the work area, and always wash your hands before eating or drinking.

To minimise the release of RCF fibres during installation and servicing a HEPA filtered vacuum is recommended to remove any dust accumulated in and around the fire both before and after working on it.

When Servicing and if replacing these parts we do not recommend they are broken up but are sealed within a heavy duty polythene Bag and labelled as "RCF waste". This is not classified as "hazardous waste" and may be disposed of at a local licensed landfill site.

There are 3off Oblong 'D' Large Coals, 2off Square 'E' Coals, 3off Triangle Coals, 8off Medium 'C' Square Coals and 3off Small 'B' Coals.

There are also Left & Right Hand Matrix's halves. Refer to the wording and diagrams.

! TIP ! Take care not to damage liner panels.

- a. Fit the Left and Right Matrix halves. You may notice small white marks on the Matrix. This is part of the production process.



! TIP ! When fitting the

- b. **Coals Layout**
Fit 2off Oblong 'D' Large Coals centrally up against the Rear Board at the back of the Fire.



Coals leave gaps between as this helps achieve the best effect.

- c. **Coals Layout**
Fit 2off Medium 'C' Square Coals, 1 each in the far left and right hand corners.



d. Coals Layout

Fit 2 off Square 'E' Coals at the Front Left and Right Corners.



e. Coals Layout

Fit 3 off Triangular Coal along the Front of the Matrix.



f. Coals Layout

Fit 2 off Medium 'C' Square Coals at the rear corners on top of the 'C' coals fitted at stage 'c' as shown.



g. Coals Layout

Fit 1 off Oblong 'D' Large Coal centrally on top of the Centre Triangle Coal just fitted.



h. Coals Layout

Fit 2 off Medium 'C' Square Coals at the back centrally on top of the Oblong 'D' Large Coals as shown.

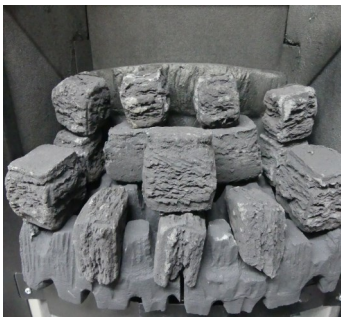

i. Coals Layout

Fit 2off Medium 'C' Square Coals one either Side of the front central Oblong 'D' Coal as shown.



j. Coals Layout

Fit 3off Small 'B' Coals, on top of the front coals 1off central and 2off towards the sides as shown.



k. Once the fire is first lit it may be necessary to adjust some of the Coals to improve the effect.

l. When first lit the flames will be quite tall and yellow; this is quite normal as production process materials are burnt off.

Important

Make the Customer aware that they will notice that after the first use the fuel bed components, Coals Matrix & Liners will change colour and this is quite normal and part of the overall effect of simulating a real coal fire.

18. - TESTING, COMMISSIONING & USE

! IMPORTANT NOTE ! During its first period of use any protective coatings and oils will burn out of the fire and it is wise to ventilate the room for the first hour; also advise the customer that this may persist for the first few days until the fire is fully burnt-in.

18.1 - LIGHTING THE FIRE

- a. Reference to Section 2 in the Users Instructions 'Lighting & Controlling the Fire' will show how to light and operate the fire.
- b. Check that the supply pressure to the fire is at the pressures required, 20mbar Natural Gas G20 when set at high.

! IMPORTANT NOTE ! Ensure that the pressure test point used is sealed and gas tight.

18.2 - TESTING FOR SPILLAGE

Note: Different sized Restrictors are supplied for Natural Gas and Propane Gas Fires.

a. There are 4 Restrictors supplied with the fire as follows:

2 Restrictors for Natural Gas marked Slim Vista+ NG - A and Slim Vista+ NG - B. (NG for Natural Gas Only)

2 Restrictors for Propane Installations marked Slim Vista+ P - A and Slim Vista+ P - B. (P for Propane Only).

The Restrictors Marked 'B' are for flue effective heights greater than 3meters but less than 4 meters high.

The Restrictors Marked 'A' are for flue effective heights greater than 4 meters high, where the flue has a good flue pull from cold.

A restrictor must not be fitted with Pre-cast Flue applications.

Without Restrictor



With Restrictor Fitted

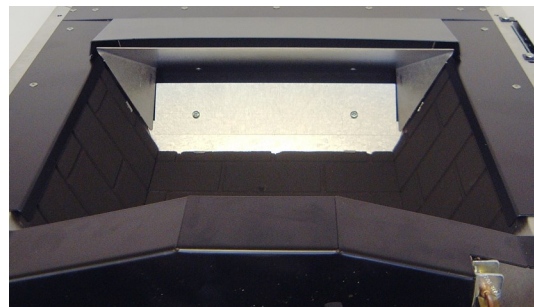

The restrictor is fitted over the outlet duct on the inside of the fire with the 2 # No.8 x 10mm pointed self tapping screws provided, see above.

- b. Once the fire is operational the installer must check for spillage. Close all doors and windows. Carry out the lighting procedure and turn the fire to high. Allow to warm up for 5 minutes and then using a lit smoke match, joss stick or similar, place centrally just under the edge of the canopy as shown below. The majority of the smoke must be drawn under the Fire Canopy. Some small whiffs of smoke may be expelled and this is quite normal. Be careful not to introduce too much smoke (i.e. by using a pellet). A smoke match tube can be used to make holding of the match easier. See following diagram.

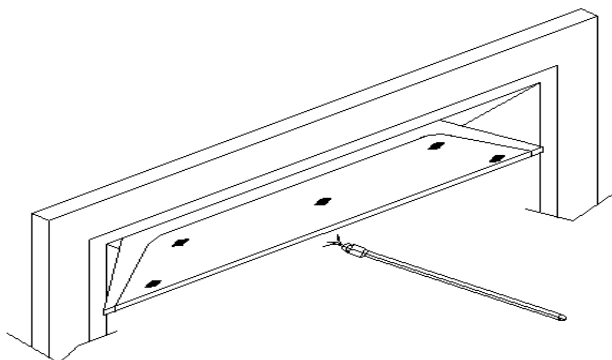

- c. Repeat the test with doors and windows to the premises/room both open and closed, and with any extractor fans in the same room or adjacent rooms running at high. The fire should continue to clear its combustion products. Also operate any other flued appliance in the same or neighbouring rooms and ensure they continue to function satisfactorily as multiple flues can work against one another.
- d. If spillage is detected during this procedure, remove the restrictor if fitted and repeat the tests.
- e. If spillage is detected and no restrictor is fitted, let the fire operate for a further 10 minutes and re-check.
- f. If the fire continues to spill, it could indicate a faulty flue or lack of ventilation. If the problem cannot be rectified immediately, disconnect the fire, affix a label and advise the customer not to use it until the problem has been resolved.
- g. **It is an offence to use or allow the use of a dangerous appliance.**

18.3 - FITTING THE OUTER TRIM & FRAME OPTIONS

(Some Trim/Fronts & Frame options are supplied separately with their own fitting Instructions and Brackets)

- a. **The Flat & Profile Outer Trims** are supplied with the fire and held in place with 4 strong Magnets, one at each corner, ensure they are in place at the corners.

Note: With Profile Frames the top Magnets must be on the metal top corner plates.

- b. To fit simply fit over the fire engaging on the magnets and slide to centralize onto the Fire.

Note : If the Trim is not positioned centrally it may not be held correctly at each corner.

The Arc Trim (Fireplace & Surround Versions) are fitted by hooking the Trim into the slots in the top brackets on the fire and then centralise before fixing at the bottom corners with the 2 long screws provided, (1 each side).

If the Front is found to be loose then the brackets on the fire are slotted to provide adjustment.

The Cast Trim is fitted by sliding it downward over the fire to hook onto the top brackets and engage into the lower brackets on the fire.

Important: The Cast Tim is quite heavy so it is important to ensure is secure by pulling at the top and then the bottom ensuring it is located in both sets of brackets.

If the Trim is found to be loose then the brackets on the fire are slotted to provide adjustment.

Note: A gap between the wall and frame is correct.

18.4 - FIREGUARDS

- a. A fireguard is not supplied with the appliance however it is recommended that a fireguard conforming to BS 7977 is fitted if the fire is to be used in the presence of young children, the elderly, the infirm and pets.
- b. For Hole in the Wall fires it is recommended that a means, (tactile separator/shelf or guard) is provided to give abrupt warning to a person moving inadvertently towards the fire.

19 - BRIEFING THE CUSTOMER

- a. The installer should brief the customer on the Operation of the Control System fitted (specifically the position for viewing the pilot for lighting, when applicable); operation of the Coal-Coke System (if applicable) and all aspects of the User Instructions.
- b. The instructions should be handed to the customer for their safe keeping and future servicing.
- c. For Customers who have purchased either of the 2 or 3 Button High Level Control explain and demonstrate that the batteries should be replaced with good quality batteries annually as the side switch may stop working part way through a season.
- d. For Customers who have purchased the Thermatronic Control explain and demonstrate that the batteries in the receiver and Handset should be replaced with good quality ones annually as the fire may stop working part way through the season.
- e. The customer should be briefed on the need for regular servicing; this will normally be once a year.
- f. Advise the customer that, apart from batteries for the High Level and Thermatronic Systems, there are no user replaceable parts in the fire but for servicing and spares to contact the local Nu-Flame Stockist.
- g. Advise the customer that under no circumstances must the fire be used if the glass panel is broken chipped, cracked or damaged.
- h. Advise the customer about the importance of checking and maintaining the Carbon Monoxide Alarm safety device.

! IMPORTANT !

ADVISE THE CUSTOMER THAT THE GLASS WILL BE BECOME VERY HOT DURING OPERATION

THE MUST NOT BE USED IF THE GLASS PANEL IS BROKEN CHIPPED, CRACKED OR DAMAGED

20 - SERVICING

The Matrix in the fire is a Moulded Ceramic Fibre component incorporating Silicone Binders and you may notice that it develops cracks during operation. This is natural shrinkage caused by exposure to high temperatures and is quite normal for the material and will in no way affect the operation of the fire.

20.1 - GENERAL

Note: Servicing must be carried out by a registered installer.

- a. The fire does not have to be removed for Servicing.
- b. Check the operation and ignition of the fire before servicing.
- c. Ensure the fire is cold before proceeding.
- d. Lay a dust sheet on the floor before proceeding.
- e. Carry out a gas soundness test before servicing.
- f. Taking great care not to mark the liners, remove the Ceramic Coals and the Matrix. (The presence of white marks and/or surface cracking/crazing on the matrix is quite normal.)
- g. Pull off the Outer Trim/Frame, (Locate the 4 magnets), and turn off the gas supply to the fire at the isolation/pressure test elbow.
- h. If any parts need replacement, use only genuine parts supplied by Nu-Flame Ltd. Some components may look similar to those used in other gas fire, but these are not necessarily the same due to performance variations and must not be used.
This applies particularly to the ODS Pilot, Gas Control System and Ceramics.
- i. Disconnect the gas pipe to the control.

! TIP ! Being Magnetic The 4 Trim Magnets can be easily misplaced,. Locate them immediately.

Remind the Customer that in the interests of Safety they MUST maintain their Carbon Monoxide Alarm.

20.2 - ANNUAL SERVICING

Carry out the operations in 20.1 General before proceeding

! IMPORTANT NOTE ! TAKE GREAT CARE WHEN WORKING INSIDE THE FIRE NOT TO MARK THE CERAMIC LINING PANELS.

- a. Referring to the Section 17, 'Arrangement of the Fuel Effect' and working in reverse order, remove the Coals and the Matrix.
(The presence of white marks and/or surface cracking/crazing on the matrix is quite normal.)
- b. With the High Level and Thermatronic Control Systems remove the Control Heat Shield, which is secured with a single screw at the base of the fire on the left side.
- c. Now remove the Burner/Control Assembly by removing the 2 screws at the front of the fire taking care not to mark the liners. Slide the Burner Assembly forward and if the fire is fitted with the High Level or Thermatronic Control it will also be necessary to carefully slide out the Battery/Receiver Box and, in the case of the Thermatronic Control, carefully pull the Infrared Sensor off its Velcro Pad. This will now allow access to all gas carrying parts for maintenance checks, fault finding and or replacement.
Take care when removing the Burner - DO NOT lift it out holding the Burner Top
- d. Remove the Debris Plate by removing the 4 screws allowing access through the Debris Opening and clear away any Debris.
- e. Brush clean the burner and pilot area of dust or debris; check that the aeration hole in the pilot is clear of dust, fluff, lint.
- f. Refit in reverse order; brushing the coals/pebbles clean of any soot, checking gas soundness, ignition and spillage as detailed in the relevant sections.

ALWAYS CONDUCT A GAS SOUNDNESS AND SPILLAGE CHECK AFTER SERVICING.

ALWAYS RESEAL THE PRESSURE TEST POINT AND CHECK THAT IT IS GAS TIGHT. (This accounts for a lot of recalls.)

ALWAYS CHECK THAT THE CONTROL SYSTEM IS WORKING CORRECTLY. (This accounts for a lot of recalls.)

21 - FAULT FINDING GUIDE, SYMPTOMS AND POSSIBLE CAUSES

Important : In instances where it is indicating that the main control system needs changing, (specifically the 3 Button High Level or Thermatronic Control Systems), you should investigate returning the whole Burner Control Assembly to Nu-Flame for rectification as this could be the least cost option.

- a. Prior to any Servicing ensure that you have carried out the procedures in Section 20.1 General (Servicing).
- b. Check the supply pressure at the isolation elbow.
- c. **Important :** With the High Level and Thermatronic Systems always change the batteries before carrying out any Fault Finding

21.1 - RESETTING THE ELECTRONIC CONTROL (Applies Only to Thermatronic RF System Only)

Full Reset - If a new handset is obtained the control system will need to learn the handset's unique code via a Full Reset. Also, if the fire is not working and the Basic Reset (described on page 6) has not worked a Full Reset can be carried out:

- a. Remove the Ash Pan Cover and locate the electronic Receiver Box.
- b. Locate the Reset Hole on the side of the Receiver and using a pen press and hold in the Reset button until you hear two beeps.
- c. The first beep is short and the second beep is long. After the second beep release the Reset Button.
- d. Now on the Handset, within the next 20 seconds press and hold the Small Flame Button until you hear two additional short beeps confirming the code is set in the Receiver.
- e. If you hear one long beep the Code as not been set so repeat the procedure.
- f. If the Handset still does not work check the wiring and or replace the Receiver and Handset .

21.2 - NO SPARK IGNITION

- a. Replace the batteries in the Receiver and Handset (The 3 Button High Level Switch as Receiver Batteries only).
- b. Check there is no dust/debris shorting out the electrode or blocking gas from the pilot.
- c. Check the condition of the Ignition lead and ensure it is connected to both the ignition electrode and /or High Level Control or receiver. Check that the Ignition lead is not trapped and or shorting, replace if required. For the Manual System this will involve a new control. For the High Level Control an the Thermatronic System a separate ignition lead is available.
- d. Check that gas is flowing from the pilot during the ignition sequence. Clean or Replace as required.
- e. For the 3 Button High Level Control & Thermatronic Radio Frequency versions only, listen to the control to hear if the pilot gas solenoid is opening. Change the Receiver and High Level Switch or the Handset (which ever applies) at the same time and/or gas control. Refer to Diagram for Cable connections in Section 22.

21.3 - PILOT GOES OUT AFTER FIRST LIGHTING

- a. Check there is no debris blocking the flame to the thermocouple.
- b. Check the thermocouple is tightly connected to the control.
- c. Change the pilot assembly as a new thermocouple may be required.
- d. With the Manual System or 2 Button High Level Control change the Controls.
- e. For the 3 Button High Level Control & Thermatronic Radio Frequency versions only, listen to the control to hear if the pilot gas solenoid is opening. Change the Receiver and High Level Switch or the Handset (which ever applies) at the same time and/or gas control. Refer to Diagram for Cable connections in Section 22.
- f. Also see Section 21.4

21.4 - PILOT LIGHTS BUT MAIN BURNER DOES NOT LIGHT

- a. With All Control Systems listen to hear if gas is flowing into the main burner.
- b. Check there is no dust or debris blocking the flame from the pilot to the main burner.
- c. With the 2 Button High Level Control check that both Control Knobs are in the on position, fully turned anti clockwise. Also check 'e' before determining the action required.
- d. With the 3 Button High Level & Thermatronic System check if the main control knob on the control is turning to the high setting and listen to hear if the valve is opening. If not change the Handset & Switch (which ever applies) and at the same time the gas control.
For removal of the 3 Button Switch refer to 'f' and also refer to the Diagram for Cable connections in Section 22. Also check 'g' (below) before considering replacing any parts. You should also consider the **Important** note in 21.1.
- e. With the 2 Button High Level Control it is possible for the Main Burner to light when first lit after lighting the Pilot but then the Push Buttons do not operate the control. Operate the bottom button and listen to see if the Control Knob turns. If it does not then change the batteries, if still a problem change the Switch Assembly as detailed in 'f'.
- f. For removal/replacement of the 2 & 3 Button Switches first remove the 2 screws retaining the Switch Shield, remove the 2 screws retaining the Switch Assembly. Disconnect the push on wire connections at the control. Remove the switch and wires and replace with a new component in reverse order.
- g. All Control Systems have a Pressure Test Point to allow the Burner Pressure to be checked to confirm if gas is flowing from the control. On the Manual Control it is visible at the front left of the control. On the High Level Controls it is on the left of the control and on the Thermatronic it is at the front of the Control and is the left/rear Pressure Test Point.
- h. Check if the main injector is blocked. Clean or Replace.

21.5 - PILOT FLAME SHORTENS, OR GOES OUT WHEN MAIN BURNER IS SELECTED

- a. Monitor the supply pressure at the isolation elbow as the main burner lights. If pressure drops, check gas pipe sizing, quality of pipe bending. Check for debris in the gas supply and or gas filter if fitted.
- b. Check that another appliance is not affecting the gas supply pressure.

21.6 - POOR FLAME PICTURE

- a. Check the supply pressure is correct at the isolation elbow. If the pressure is low, check gas pipe sizing, quality of pipe bending. Check for debris in the gas supply and or gas filter if fitted.
- b. All Control Systems have a pressure point to allow the Burner Pressure to be checked. On the Manual Control it is visible at the front left of the control. On High Level Control it is on the left of the control and on the Thermatronic it is at the front of the Control and is the left/rear Pressure Test Point. You may wish to check 'c' first.
- c. With the High Level Controls check the Buttons are operating correctly see Sections 21.3 & 21.4.
- d. Check that another appliance is not affecting the gas supply pressure.
- e. Check there is not a flue/ventilation problem – carry out a spillage test.
- f. Check fuel bed layout as detailed in Section 17.

21.7 - FIRE OPERATES FOR A WHILE THEN GOES OUT

- a. Check the supply pressure is correct at the isolation elbow with all other gas appliances working. If the pressure is low or fluctuating up and down check gas pipe sizing, quality of pipe bending. Check for debris in the gas supply, pilot pipe and or gas filter if fitted.
- b. Carry out a spillage test from cold. Look for signs of Discoloured Walls or Trims as this may be an indication of a Downdraught Problem.
- c. Establish how long the fire stays alight then repeat the Spillage Test around this time.
- d. For the Thermatronic System check that the Control is functioning correctly as detailed in Section 21.2 specifically the Thermocouple Electrical Connections and Pilot Flame size.
Downdraught problems can be related to the condition of the flue, chimney termination or geographical location; so if a Flue Problem is thought likely but no problem is found during the investigation isolate the fire and seek expert advice.

21.8 - THERMATRONIC RADIO FREQUENCY CONTROL SYSTEM DOES NOT OPERATE

- a. Check the Control is being operated correctly - see Section 2.2
- b. Check for error messages and check batteries - see Section 2.3
- c. Reset the Mertik Maxitrol Logic Circuits - see Section 21.1

21.9 - HIGH LEVEL PUSH BUTTON CONTROLS DO NOT OPERATE

- a. Change the batteries then see if the push buttons now operate.
- b. The Switch and Receiver/Battery Box should be replaced.

Important : In instances where it is indicating that the main control system needs changing, (specifically the 3 Button High Level or Thermatronic Control Systems), you should investigate returning the whole Burner Control Assembly to Nu-Flame for rectification as this could be the least cost option.

ALWAYS CONDUCT A GAS SOUNDNESS AND SPILLAGE CHECK AFTER SERVICING.

ALWAYS RESEAL THE PRESSURE TEST POINTS YOU HAVE USED AND CHECK THAT THEY ARE GAS TIGHT.

(This accounts for a lot of recalls.)

ALWAYS CHECK THAT THE CONTROL SYSTEM IS WORKING CORRECTLY. (This accounts for a lot of recalls.)

ENERGIS SLIMLINE VISTA+ (Natural Gas)

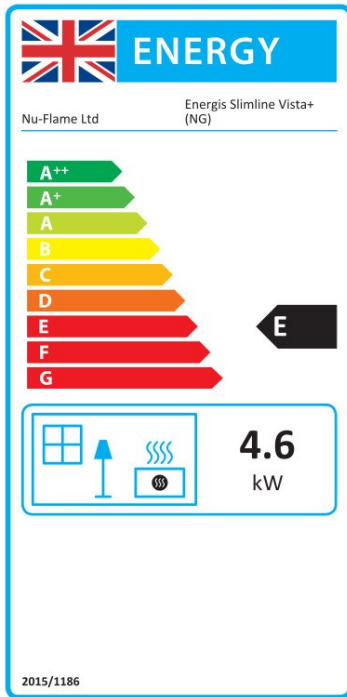

Supplier	Nu-Flame Limited
Model	Energis Slimline Vista+ (NG)
Energy Efficiency Class	E
Direct Heat Output	4.6kW
Energy Efficiency Index	62.7
Useful Energy Efficiency at Maximum	73.7%
Useful Energy Efficiency at Minimum	62.5%

The fire must be Installed & serviced by a properly qualified (in accordance with Local & National Codes) Installation Engineer and in accordance with these Installation Instructions

ENERGIS SLIMLINE VISTA+ (Propane)

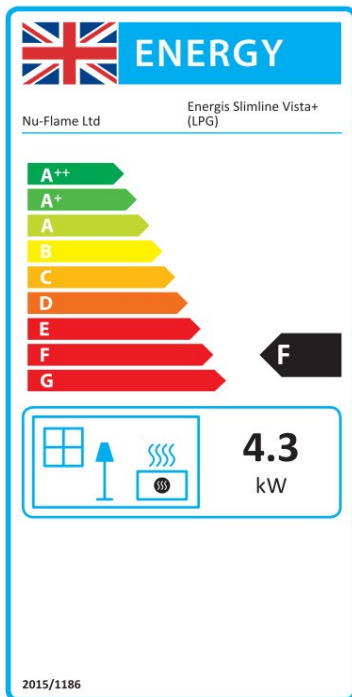

Supplier	Nu-Flame Limited
Model	Energis Slimline Vista+ LPG)
Energy Efficiency Class	F
Direct Heat Output	4.3kW
Energy Efficiency Index	61.1
Useful Energy Efficiency at Maximum	72.1%
Useful Energy Efficiency at Minimum	62.5%

The fire must be Installed & serviced by a properly qualified (in accordance with Local & National Codes) Installation Engineer and in accordance with these Installation Instructions

ENERGIS SLIMLINE VISTA+ (Natural Gas)

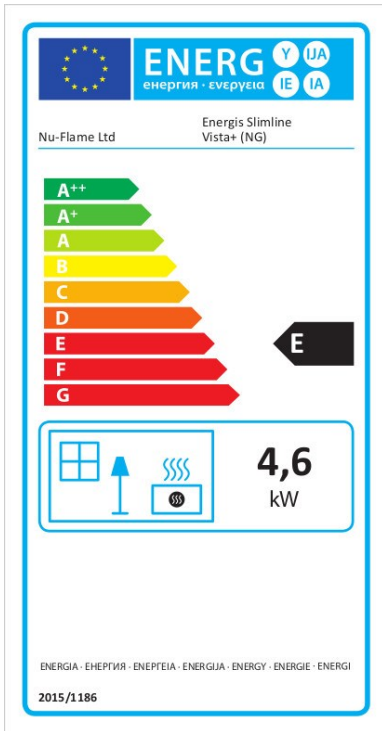

Supplier	Nu-Flame Limited
Model	Energis Slimline Vista+ (NG)
Energy Efficiency Class	E
Direct Heat Output	4.6kW
Energy Efficiency Index	62.7
Useful Energy Efficiency at Maximum	73.7%
Useful Energy Efficiency at Minimum	62.5%
<p>The fire must be Installed & serviced by a properly qualified (in accordance with Local & National Codes) Installation Engineer and in accordance with these Installation Instructions</p>	

ENERGIS SLIMLINE VISTA+ (Propane)

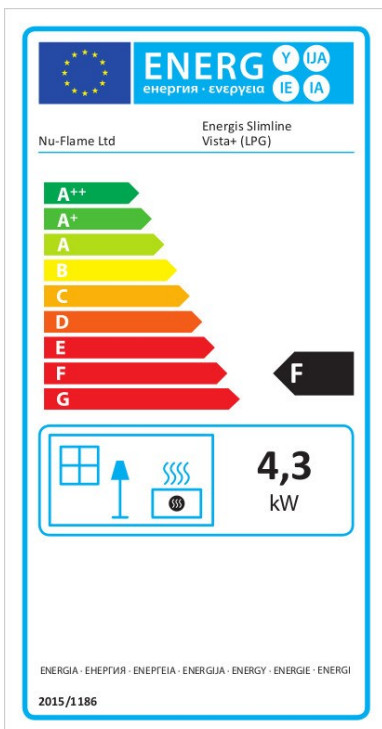

Supplier	Nu-Flame Limited
Model	Energis Slimline Vista+ LPG)
Energy Efficiency Class	F
Direct Heat Output	4.3kW
Energy Efficiency Index	61.1
Useful Energy Efficiency at Maximum	72.1%
Useful Energy Efficiency at Minimum	62.5%
<p>The fire must be Installed & serviced by a properly qualified (in accordance with Local & National Codes) Installation Engineer and in accordance with these Installation Instructions</p>	

UK Declaration of Conformity

Name of the Client : Nu-Flame Ltd
Address of the Client : Unit 4
: Kimpton Trade & Business Centre
: Minden Road
: Sutton
: Surrey
: SM3 9PF

Telephone : 020 8641 9992

Manufacturing Location : As above

This declaration of conformity is issued under the sole responsibility of the manufacturer above for:

Product : Energis Slimline Vista+

Certificate Number : UKCA 744503

The object of the declaration described above is in conformity with relevant harmonized legislation

Regulation 2016/426 on gas appliances as brought into UK law and amended.

The following harmonised standards and technical specification have been applied:

BS 7977-1: 2009 + A1: 2013 Specification for safety and rational use of energy of domestic gas appliances – Part 1: Radiant/convectors

Where the Essential Requirements of the GAR have been met and approved by Notified Body:

Responsible Test House : BSI Group
Address : Holywell Park
: Ashby Road
: Loughborough
: LE11 3AQ
: United Kingdom

Authorized Signature of Manufacturer:



Date of Issue: 19th April 2021

EU Declaration of Conformity

Name of the Client : Nu-Flame Ltd
Address of the Client : Unit 4
: Kimpton Trade & Business Centre
: Minden Road
: Sutton
: Surrey
: SM3 9PF

Telephone : 020 8641 9992

Manufacturing Location : As above

This declaration of conformity is issued under the sole responsibility of the manufacturer above for:

Product : Energis Slimline Vista+

Certificate Number : CE688450

The object of the declaration described above is in conformity with relevant harmonized legislation

Gas Appliance Regulation (EU) 2016/426

The following harmonised standards and technical specification have been applied:

BS 7977-1: 2009 + A1: 2013 Specification for safety and rational use of energy of domestic gas appliances – Part 1: Radiant/convectors

Where the Essential Requirements of the GAR have been met and approved by Notified Body:

Responsible Test House : BSI Group
Address : Holywell Park
: Ashby Road
: Loughborough
: LE11 3AQ
: United Kingdom

Authorized Signature of Manufacturer:



Date of Issue: 21st April 2018

24. - DIAGRAM OF INFRARED CONTROL SYSTEM

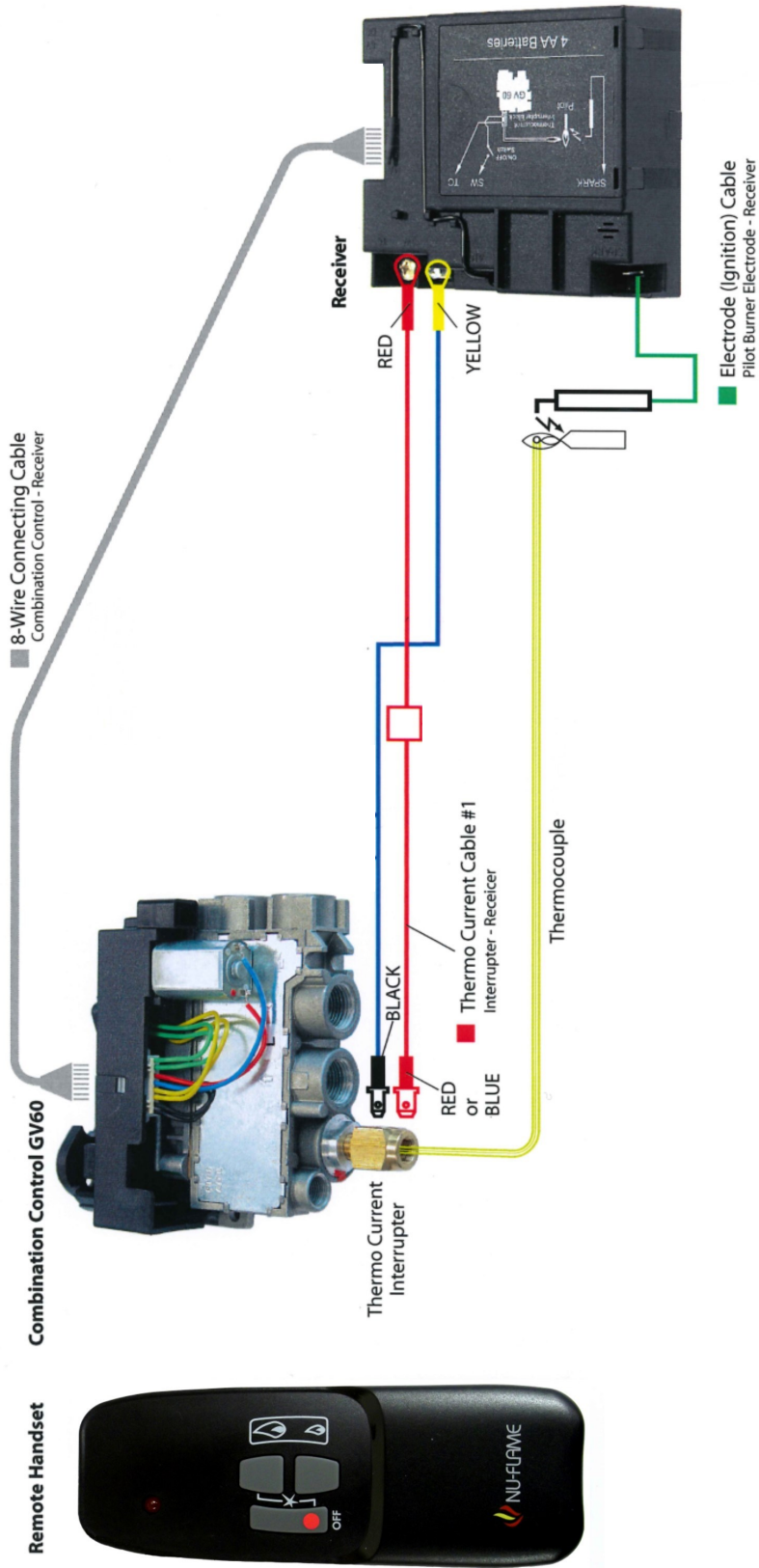



Telephone 020 8254 6802

Nu-Flame Warranty and Repair Procedure for The Energis Slimline Vista+

Nu-Flame fires are guaranteed for 1 year from the date of purchase. During that time our guarantee is to repair at our option, or replace at no charge a fire that proves to have faulty components or workmanship.

Telephone Help Line. In the event of a problem with a fire the first course of action should be to telephone our technical department on 020 8254 6802 during normal working hours 9 - 5.30 Monday - Friday (closed 1 - 1.30). If appropriate this should be done before the installer leaves site as we may well be able to resolve the problem over the phone and in any event it may well save the installer a return visit to site. If we are not able to resolve the problem over the phone we may ask you to return the fire, and will log your details and give you a return reference number.

Returning the Fire and parts thereof. After assessment we might consider it best to return part of the appliance, such as the burner only, for testing. In this example the burner can then be thoroughly inspected and any signs of installation faults can be reported back to you. After any repair work is carried out the flow rates can be checked and re-set if necessary in order to fully comply with CE approval. **Note:** It is a condition of the warranty that you do not return any parts to us unless we request you to do so. For example if we request that the burner only is returned and you send the entire appliance, the fuel bed and other items could be damaged or lost during the return delivery to us. We will not be liable for any such breakages, or losses

Under no circumstances should any attempt be made to repair the burner on site without our express knowledge and approval during the warranty period.

This guarantee is given subject to the following provisions:

1. That the installation is carried out by a GAS SAFE registered installer (we may require their registration details).
2. That the appliance is installed and used in accordance with our Installation & User instructions.
3. That the gas supply pressure at the appliance is not more than 3mbar below the gas pressure stated on the data plate when the appliance is running on high flame, with any other major gas appliances also running.
4. That the fireplace and flue system conform to relevant local codes, building regulations and British Standards.
5. This Guarantee is not transferable and relates to the original installation only.
6. The appliance has not been subject to misuse or accident or been modified or repaired by any person other than the authorised employee or authorised representative of Nu-Flame Ltd.
7. The Record Data section on the front of the Installation & Servicing Instructions is to be completed on installation.
8. Nu-Flame Ltd accepts no liability for any consequential loss or damage arising from the use or failure of the product or any information provided, including, but not limited to, economic or financial loss, damage to peripheral equipment or products, loss of use, productivity or time.
9. That the serial no. data plate on the burner is intact.

This guarantee in no way reduces your statutory rights.

This guarantee supersedes any previously published guarantees.

Chargeable Repairs During And After The Warranty Period

If a repair is chargeable during the warranty period, due to installation faults we will inform you and where possible give you a quote, or if this is not possible, a price guide before starting work. We cannot always give a firm cost until we commence the repair as it is not always possible to tell which components have been damaged.