



THE SLIMLINE RADIANT H.E.

**Heater Suitable For Natural Gas at Inlet Pressure 20mbar
or Propane at Inlet Pressure 37mbar**

USE, INSTALLATION & SERVICING INSTRUCTIONS

**ALL INSTRUCTIONS MUST BE LEFT WITH THE USER FOR
SAFE KEEPING**

MANUFACTURED by:
Nu-Flame Limited
Unit 4, Kimpton Trade & Business Centre
Minden Road, Sutton, Surrey SM3 9PF
Tel: 020 8254 6802
Fax: 020 8641 9992
Email: sales@nu-flame.co.uk

Country of Destination - GB & IE

CONTENTS

Section No	Subject	Page
User Section		
-	Contents Page	2
-	Box Contents	2
-	Fitting Kit Contents	3
1	Important Notes	4
2	Lighting & Controlling the Fire	5
3	Cleaning the Fire	7
4	Servicing	7
Installation Section		
-	Record Data	7
5	Installation Requirements	8
6	Appliance Data	8
7	Appliance Dimensions	8
8	Fret Requirements	9
9	Flue Requirements	9
10	Ventilation	9
11	Gas Supply	10
<i>Sections 12 - 15 are for the various installation applications - Ensure you refer to the section relevant to your requirement</i>		
12	Class 1 & Lined Flue Fire Surround Application Fireplace Construction	11
13	Pre-Cast Fireplace Application - Fireplace Construction (Rebated or Purpose Built Fire Surround & Construction)	12
14	BS715 Shallow Flue Box with 5" Twin Wall Flue Application (Fireplace or Hole in the Wall Construction)	14
15	Hole in the Wall Application into Class 1 & Lined Flue Builders Opening Construction	16
16	Fixing the Fire	17
17	Arrangement of the Fuel Effect	19
18	Testing, Commissioning & Use	21
19	Briefing the Customer	22
20	Servicing	22
21	Fault Finding Guide, Symptoms & Possible Cause	23
22	Diagram of Infrared Control System	25
-	Guarantee	26

BOX CONTENTS

The Fire comes in 1 box containing the Fire with chosen Control and Fitting kit (see next page for fitting kit contents) plus the chosen Fuel Bed Components (Coals or Pebbles), and Fret if ordered may come in a separate box.

THE SLIMLINE RADIANT H.E. FITTING KIT CONTENTS:

Cable Fixing Kit (2 # cables and fittings, 4 # eyebolts, 4 # screws and 4 # plastic plugs).

1 # Flue Restrictor.

2 # No8 x 10mm pointed self tapping screws for the restrictor.

4 # Magnets for holding Front Trim on.

1 # 2,050mm length of 6mm x 4mm self adhesive silicone sealing strip.

1 # 10mm Back Nut & olive to connect 8mm copper pipe gas supply to the burner (via the isolation elbow).

1 # Set of Instructions / Warranty.

THE SLIMLINE RADIANT H.E.

USER INSTRUCTIONS

1. - IMPORTANT NOTES

- a. This appliance must be installed by a properly qualified (in accordance with National & Local Regulations) Installation Engineer.
- b. The connection of this appliance and ventilation requirements (if any) are to be according to National & Local Codes.
- c. This appliance does not normally require any purpose provided additional ventilation, however if it has been found necessary to add a vent periodically check that it is free from obstruction.
- d. Consult all Instructions before Installation and Use.
- e. Do not throw rubbish on, or attempt to burn any materials on this appliance. Any Debris or Foreign Matter must be removed from the fire.
- f. The outer parts of this fire will become hot during use, cloths or combustible items must not be placed close to or on the fire. We recommend that a Fireguard conforming to BS8423 should be used for protection of Young Children the Elderly, Infirm and Pets.
- g. For Fires Installed above floor level, (Hole in the wall Fires), it is recommended that a means, (tactile separator/shelf or guard) is provided to give abrupt warning to a person moving inadvertently towards the fire.
- h. The appliance should be Serviced Annually in accordance with the Gas Safety & Uses Regulations.
- i. Where the flue has been used for Solid Fuel it must be swept before Installation.
- j. If at any time you smell gas or fumes turn the fire off and contact your Installer.
- k. These Instructions must be left with the User for future reference.
- l. During its first period of use any protective coatings and oils will burn out of the appliance and it is wise to ventilate the room for the first hour of use.
- m. This appliance is fitted with an oxygen depletion sensing system, which automatically shuts off the gas supply to the fire if the oxygen level in the room is depleted, due to lack of primary air, or obstructed flue (blocked chimney) that would lead to incomplete combustion of the gas. It must not be tampered with and only replaced with a genuine Nu-Flame ODS.
- n. In the event that the fire shuts down for any reason, attempt to restart it. If there is a continuing problem, call in a properly qualified specialist engineer.
- o. There are no user replaceable parts in the appliance apart from the batteries, if a High Level or Thermatronic Electronic Control System was ordered.
- p. The chimney should be regularly checked to ensure that all the products of combustion are entering the flue & that there is no build up of soot. If there is, the appliance must be serviced.
- q. Coal or Pebble fuel effects, manufactured from refractory fibre, are supplied with this appliance. Do not use real coals or pebbles as this is dangerous. If the simulated fuel bed components need renewing please obtain suitable replacements from a Nu-Flame Stockist.
- r. The fire must be installed in accordance with the rules in force and these Instructions it must be installed into a fireplace or builders opening as detailed in these Instructions.
- s. No combustible materials e.g. curtains must be closer than 500mm to the fire.
- t. For Fire Surround Applications a 150mm (6") combustible shelf can be fitted above the fire provided it is 150mm above the Fireplace Opening.
- u. The Fire can be installed into a suitably designed fire surround with a 150°C Rating.
- v. Explain to the customer that over time some wall staining will occur above the fire and this is due primarily to particles of dust present in the hot convection air circulating up and over the fire/surround and sticking to the wall.

It is quite normal for the fire to make popping and burbling sounds when in use, as would a solid fuel fire.

2. - LIGHTING & CONTROLLING THE FIRE

General

The fire is available with 4 Control Options: a Manual Control (Fire is lit and adjusted manually), a side Trim fitted 2 Button High Level Control (Fire when lit can be controlled with the Push Buttons), a side Trim fitted 3 Button High Level Control (Fire can be lit and controlled with the Push Buttons) or Thematronic Radio Frequency Electronic Control System (Fire is lit and operated with the Handset). Some Models also have a Coal / Coke Effect Lever System see 2.7

2.1 - LIGHTING & CONTROLLING THE FIRE – MANUAL CONTROL

Remove the Ash Pan Cover to get access to the Control Knob used to operate the Fire.

- Switching On/Ignition.** Depress the control knob & turn counter clockwise. Gas will flow to the Pilot Burner (Pilot Burner is visible looking down through the glass at the left side), the Piezo Igniter will give off first one, then, as you turn, a second high voltage spark & the Pilot Burner will Light. (More than one attempt may have to be made on first lighting.) Keep the Control Knob depressed for approximately 10 seconds to heat up the Thermocouple. Turn the Control Knob fully counter clockwise to release gas to the Main Burner.
- Control of Gas Flow.** Turning the Control Knob clockwise reduces the gas flow from Maximum to the Pre-Set Minimum Setting. Turning between Maximum & Minimum does not actuate the Piezo Igniter. The Control Valve can only be turned on to the Pilot setting by depressing the control knob & turning it to the pre-selected pilot position.
- Switching Off.** Press the Control Knob in at the Pilot Position & turn Clockwise to Off.

2.2 - LIGHTING & CONTROLLING THE FIRE – 2 BUTTON HIGH LEVEL CONTROL

Requires Pilot Ignition First.

The side trim positioned High Level Control System is a battery operated gas fire control system that uses push buttons linked to a main control at the base of the fire. This control system is used with an oxypilot and has all the safety features required by law and CE approval. Once the fire is lit by operating the Control behind the Ash Pan Cover the settings can be controlled by the 2 Push Buttons on the upper right side of the Trim.

Using the System

Remove the Ash Pan Cover to get access to the Control Knob used to operate the Fire.

- Switching On/Ignition.** Depress the right control knob & turn counter clockwise. Gas will flow to the Pilot Burner (Pilot Burner is visible looking through the fender, under the flue bed, at the front right hand corner), the integral Piezo Igniter will also give off a high voltage spark & the Pilot Burner will Light. (More than one attempt may have to be made on first lighting.) Keep the Control Knob depressed for approximately 10 seconds to heat up the Thermocouple. Turn the Control Knob fully counter clockwise to release gas to the Main Burner.
- Control of Gas Flow Using the Side Trim Push Buttons.** Press the lowest button to gradually reduce the gas flow from Maximum to the Pre-Set Minimum Setting, you will hear the motor turning the control. Keeping the Lower Button depressed will eventually turn the main burner off leaving the pilot alight. To relight the main burner or increase the heat setting from low, press the Upper Button to achieve settings between low and high. When the fire has reached high the control under the fire will click repeatedly, release the button.
- Switching Off.** Remove the Ash Pan Cover and turn the right Control Knob Clockwise to Off.
- Battery Replacement .** The Batteries should be replaced every season, you will notice they need changing as gradually the Push Buttons cease to operate the Control.
- Changing the Batteries.** Remove the Ash Pan Cover and you will find the Battery Box on the left hand side. Pull towards the front taking care not to strain the connecting wire. Using a small screw driver remove the screw, slide off the cover and take out the Batteries. Replace with 4 x AA good quality alkaline batteries, operate the Push Buttons to check the Batteries are fitted correctly.

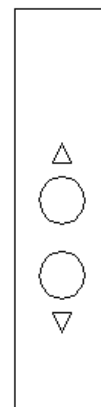

Note: Only Change The Batteries When The Fire Is Cold

2.3 - LIGHTING & CONTROLLING THE FIRE - 3 BUTTON HIGH LEVEL CONTROL

The 3 Button High Level Control Lights the Pilot and Controls the Fire.

The side trim positioned High Level Control System is a battery operated gas fire control system that uses push buttons linked to a main control at the base of the fire. This control system is used with an oxypilot and has all the safety features required by law and CE approval.

Note: The Centre Button is both the Ignition and Off Button.

Using the System

- Ignition.** Simultaneously press and hold the Centre Button until a short acoustic signal confirms that the sequence has begun, then release the buttons. Continuous audible signals confirm that ignition is in progress. When pilot ignition is confirmed the motor will open the valve to maximum flame height – this takes about 30 seconds. When the fire is first operated and on occasions when the fire has not been used for some time the Pilot may not light after pressing the Centre Ignition Button even though the acoustic sound may have been heard. On these occasions it may be necessary to repeat the sequence a number of times to light the pilot. This is quite normal.
- Flame Height Adjustment.** Press the bottom down arrow button until the flame height is at the desired position. If you try to go beyond the preset low flame minimum height the fire will turn off leaving the pilot burner alight (This is the standby position). You will learn from experience the minimum preset flame height.
- Relighting the Fire.** To relight the fire from the standby position, or to increase the flame height from low flame, press the top up arrow. Please note that you can have the flame height anywhere between maximum and preset low. For fine adjustment simply tap the up or down arrows.
- Switching Off.** Press the centre button.



- e. **Battery Replacement.** The Batteries should be replaced every season, you will notice they need changing as gradually the Push Buttons cease to operate the Control.
- f. **Changing the Receiver Batteries.** To change the Receiver Batteries remove the Ash Pan Cover and locate the electronic receiver box, underneath the fire on the left hand side. Slide open the plastic cover to gain access to the battery compartment. You can detach the Receiver by pulling it off its Velcro Pad to make access easier but remember to put it back in the same position. Replace with 4 x AA good quality alkaline batteries, operate the Push Buttons to check the Batteries are fitted correctly.

Note: Only Change The Batteries When The Fire Is Cold

2.4 - LIGHTING & CONTROLLING THE FIRE - THERMATRONIC RF CONTROL

The Thermatronic Control System is a battery operated gas fire control system that uses a microprocessor to provide the working sequences needed by the fire, and when used with an oxypilot has all the safety features required by law and CE approval. Commands are accepted by the microprocessor when buttons are pressed. An audible beep means that the command is received, and the push button should immediately be released.

Using the System

Control can only be achieved if the Handset is pointed at the Fire.

The red light will flash each time you press the Handset.

- a. **Ignition.** Simultaneously press and hold the red button and the right upper button (linked by line) until a short acoustic signal confirms that the sequence has begun, then release the buttons. Continuous audible signals confirm that ignition is in progress. When pilot ignition is confirmed the motor will open the valve to maximum flame height – this takes about 30 seconds.
- b. **Flame Height Adjustment.** Press the small flame button until the flame height is at the desired position. If you try to go beyond the preset low flame minimum height the main burner will turn off leaving the pilot burner alight (this is the standby position). You will learn from experience the preset low flame minimum height.
- c. **Relighting the Fire.** To relight the fire from the standby position, or to increase the flame height from low flame press and hold the large flame button until the desired flame height is achieved. Please note that you can have the flame height anywhere between maximum and preset low. For fine adjustment simply tap the small or large flame buttons.
- d. **Switching Off.** Press the red/off button on the Handset.



2.5 - GENERAL

- a. Battery replacement is recommended at the beginning of each heating season, or when an acoustic error message sounds during ignition.
- b. Error Message – Long signals (0.8 second tone – 0.2 second break) during ignition – probable cause - batteries in electronic receiver box are nearly discharged.
- c. Error Message – 5 second continuous tone – probable cause – cable disconnected or on/off switch on valve is in off position.
- d. Batteries - Electronic Receiver Box - 4 x AA good quality alkaline - Handset - 1 x PP3 good quality alkaline.
- e. To change the Handset battery slide open the plastic panel on the back of the Handset.
- f. To change the Receiver Batteries remove the Ash Pan Cover and locate the electronic receiver box, underneath the fire on the left hand side. Slide open the plastic cover to gain access to the battery compartment. You can detach the Receiver by pulling it off its Velcro Pad to make access easier but remember to put it back in the same position.

Note: Only Change The Batteries When The Fire Is Cold

2.6 - RESETTING THE MERTIK MAXITROL LOGIC CIRCUITS

ONLY APPLIES TO THE THERMATRONIC HAND HELD RADIO FREQUENCY CONTROL

Basic Reset - It sometimes happens that (such as when the handset buttons are pressed out of sequence) the fire stops working because the logic circuits get confused and need to be reset.

To do this, simply remove the 4 x AA batteries from the Receiver Box (see section 2.5f above), wait for 1 minute and then refit the batteries. Wait for another minute and then point the handset at the fire and press the red/off button. Wait for another minute and then start the fire as normal. If the fire does not start repeat the resetting procedure. If the fire still does not work a Full Reset can be tried.

Full Reset - If you obtain a new handset the control system will need to learn the handset's unique code via a Full Reset. Also, if the fire is not working and the Basic Reset has not worked a Full Reset can be carried out:

Remove the Ash Pan Cover and locate the electronic Receiver Box.

Locate the Reset Hole on the side of the Receiver and using a pen press and hold in the Reset button until you hear two beeps.

The first beep is short and the second beep is long. After the second beep release the Reset Button.

Now on the Handset, within the next 20 seconds press and hold the Small Flame Button until you hear two additional short beeps confirming the code is set in the Receiver.

If you hear one long beep the Code as not been set so repeat the procedure.

If after carrying out the above procedure the situation is not corrected it will be necessary to contact your Installer.

Note: For the Installation/Service Engineer - Resetting of the Handset & Control System is also covered in Section 21.1 page 23.

2.7.- COAL-COKE EFFECT LEVER

Note : This Feature is **not used** on either the Natural Gas Pebble Fire or the Propane Fires.

The Natural Gas Coal Fire Model is fitted with a control lever to enable different flame effects to be created. With the lever pushed-in the flames will be quite yellow replicating a Coal Fire Flame Effect. With the lever pulled-out the flames will be more blue replicating a Coke Fire Flame Effect. **The Coke Fire Flame Effect setting provides the hottest and most efficient Heat Output for the Fire.**

- a. Remove the Ash Pan and at the upper centre of the opening you will see the black Coal-Coke Lever. Push the lever in for the Coal Effect setting, pull the lever out for the Coke Effect setting.

! IMPORTANT ! On the Coal Setting, the Yellow Flames may cause some sooty deposits to form and to reduce this we recommend changing to the hottest Coke Setting.

! TIP ! On the Coke Setting the Fire Produces More Heat and is operating at its most Efficient Heat Setting.

3. - CLEANING THE FIRE

- a. Allow to cool before cleaning.
- b. The outer surfaces of the fire can be cleaned with a damp cloth and lightly polished with a duster, do **not** use abrasive cleaners. For Stainless Steel finishes we recommend a small amount of Baby Oil.

4. - SERVICING

- a. The fire should be Serviced Annually in accordance with the Gas Safety & Uses Regulations.
- b. This fire contains no User Serviceable Parts apart from the batteries which are only used with the High Level and Thermatronic Control System options.
- c. Servicing must be carried out by a Registered Installer.
- d. For Servicing or Spare Parts contact your Installer quoting the Fire Name, Model and Serial Number, which can be found on the Data Badge. To find the Data Badge/Plate; with the fire cool remove the Ash Pan Cover, the Data Badge can be found at the base next to the Control Knob.
- e. In the event that the fire shuts down due to any reason, attempt to restart it. If there is a continuing problem, call in a properly qualified specialist engineer.
- f. The Matrix in the fire is a Moulded Ceramic Fibre component incorporating Silicone Binders and you may notice that it develops cracks during operation. This is natural shrinkage caused by exposure to high temperatures and is quite normal for the material and will in no way affect the operation of the fire.

THE SLIMLINE RADIANT H.E. INSTALLATION & SERVICING INSTRUCTIONS

RECORD DATA TO BE COMPLETED & KEPT BY USER:

PLACE OF PURCHASE DATE

ADDRESS & TEL. NO.
.....
.....

APPLIANCE SERIAL NO.

INSTALLED BY GAS SAFE REG. NO.

5. - INSTALLATION REQUIREMENTS

THIS APPLIANCE MUST BE INSTALLED AND SERVICED BY A PROPERLY QUALIFIED, (IN ACCORDANCE WITH LOCAL & NATIONAL CODES), INSTALLATION ENGINEER.

It is the Law in the UK that All gas appliances are installed by a competent person in accordance with the GAS SAFETY (INSTALLATION AND USE) REGULATIONS 1998 (As amended), the relevant British Standards for Installation work, Building Regulations, Codes of Practice and these Instructions. In the UK a Registered Installer is deemed competent. In the Republic of Ireland, all Irish Standards, Local Codes and Bord Gais recommendations should be adhered to.

The Installation should also be carried out in accordance with the following where relevant:

1. BS5871 Part 2 2. BS5440 Parts 1 & 2 3. BS6461 Parts 1 & 2 4. BS6891 5. BS8303 6. BS EN 1856 7. BS715
Building Regulations and Standards issued as relevant by the Department of the Environment or the Scottish Development Department.

In the Republic of Ireland Installation should be carried out in accordance with IS813, ICP3, IS327, Building Regulations, Codes of Practice, these Manufacturers Instructions and any Rules In Force.

Particular Reference should be made to the Ventilation Requirements, for the UK this Appliance would not normally require any additional purpose provided ventilation, for the Republic of Ireland ventilation should be in accordance with IS813 Domestic Gas Installations.

Failure to comply with the above could leave the Installer Liable to Prosecution and Invalidate the Warranty.

IMPORTANT

BEFORE PROCEEDING WITH THE INSTALLATION READ THESE INSTRUCTIONS CAREFULLY. THESE INSTRUCTIONS SHOULD BE LEFT WITH THE USER FOR SAFE KEEPING AND FUTURE SERVICING. PRIOR TO INSTALLATION ENSURE THAT THE GAS TYPE AND PRESSURE ARE AS STATED ON THE APPLIANCE DATA BADGE.

6. - APPLIANCE DATA

- a. Gas Type: See Data Plate (Natural Gas at 20mbar or Propane at 37mbar).
- b. Burner Pressure: Natural Gas 18.0mbar cold. Propane 35.8mbar cold.
- c. Control System: Manual or High Level (Push Button) or Thermatronic (Fully Sequential) Control System operated by Handset pointed at Receiver.
- d. Fire Safety: Oxygen Depletion & Flame Failure Device.
- e. Ignition: Manual-Integral Piezo Igniter, High Level-Integral Piezo Igniter, Thermatronic-Full Sequential Control.
- f. Inlet Connection: 8mm Compression Fitting to Gas Isolation Elbow.
- g. Category: I2H & I3P.
- h. Injector: Natural Gas (G20) - 480 Multi hole. Propane (G31) - 210 Single hole.
- i. Heat Input: High: Natural Gas (G20) - 6.95kW Gross (6.26kW Nett). Propane (G31) - 6.65kW Gross (6.12kW Nett).
- j. Heat Input: Low: Natural Gas (G20) - 2.0kW Gross (1.8kW Nett). Propane (G31) - 2.0Kw Gross (1.8kW Nett).
- k. Efficiency Class: 2. The Efficiency of this appliance has been measured as specified in BS7977-1:2009 and the results obtained were Natural Gas 61.2% Gross (67.9% Nett), Propane 61.2% Gross (67.9% Nett). The test data has been certified by BSi Group (0087) and can be used in the UK Government's Standard Assessment Procedure (SAP) for Energy Rating of Dwellings.
- l. Heat Output: High: Natural Gas (G20) - 4.3kW. Propane (G31) - 4.1kW
- m. Heat Output: Low: Natural Gas (G20) - 1.1kW. Propane (G31) - 1.1kW
- n. Pilot ODS Type: Natural Gas (G20) - P448 or NG9033 or NG9090. Propane (G31) - P449 or LPG9025.

7. - APPLIANCE DIMENSIONS

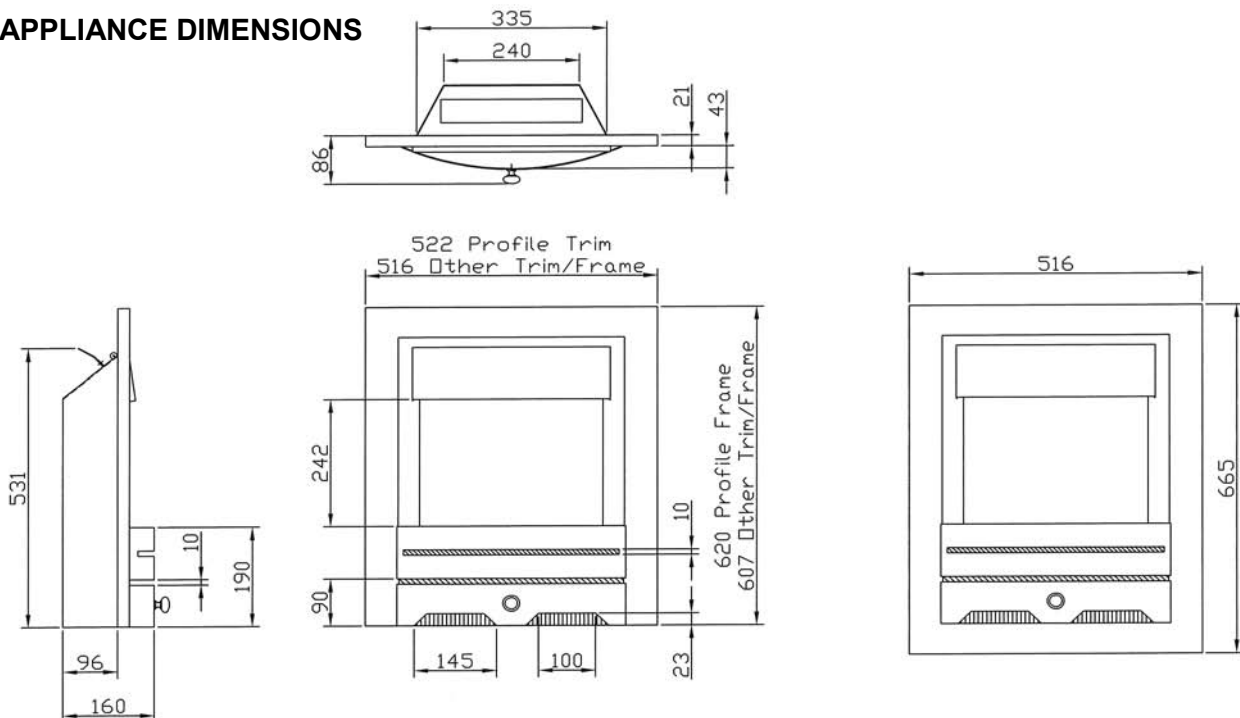

With 3 sided frame for fireplace use.

Additional detail for "Hole in the Wall" frames

Designs may vary; the diagram above is to show important dimensions

8. - FRET REQUIREMENTS

!IMPORTANT NOTE! THE FRET CAN AFFECT THE SAFE OPERATION OF THE FIRE

These checks MUST be made before selecting a suitable Fret

- The Important Minimum Open Area's (for airflow) of the Fret are shown in the diagram, with the minimum dimensions .
- The Minimum Open Area at the base of the Ash Pan Cover is 5200mm sq equally shared between two openings, they must be at the base of the Ash Pan Cover.
- The Minimum Open Area in the Fender area (above Ash Pan Cover) is 7500mm sq which can be provided through one or more slots.
- The correct height to the Upper most part of the Fret must be 190mm, to align with the Fuel Bed.
- The opening for the Ash Pan Cover area must be 85mm minimum height to allow access for operation of the Controls.
- The Fret will have to be curved at the back and must be checked to ensure it does not foul the Matrix of the Fuel Bed. It should also touch the Trim.

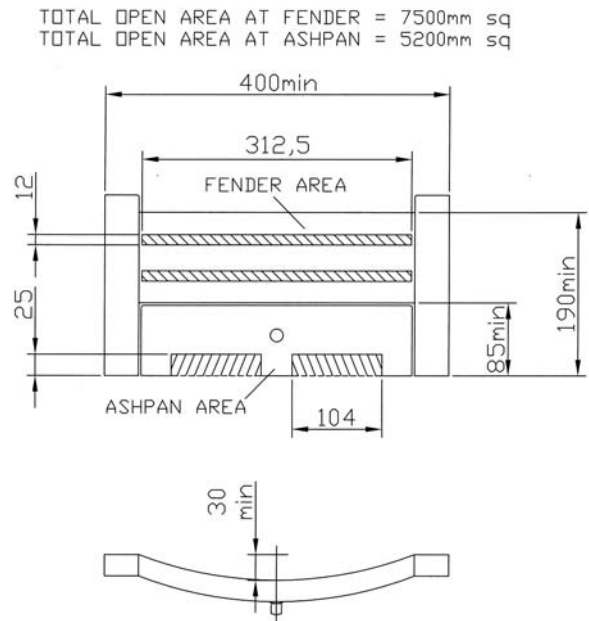

THE SHADED AREAS ARE THE MINIMUM SIZED OPENINGS

9. - FLUE REQUIREMENTS

These checks MUST be made before constructing the Builders Opening

The Appliance is suitable for Installation into the following types of Flue:

- Conventional Stone/Brick Built Flue (Class 1) with a minimum cross sectional dimension of 175mm (7") with a minimum effective height of 3 meters.
- The flue **MUST** be free of any obstructions. Any dampers or restrictors **MUST** be removed. Some dampers are impractical to be removed; therefore they **MUST** be fixed in some way in the **OPEN** position.
- The chimney/flue should be swept if it has been used for solid fuel.
- A Flue Lined with a 5" Flexible Flue Liner connected to a Register Plate fitted and sealed at the top of the Builders Opening with a minimum effective height of 3 meters.
- A Pre-cast Flue with Starter Blocks conforming to BS1289: 1975, 1986, or 1989 or BS EN1858 and having a minimum cross sectional flue of 198mm by 67mm and Starter Blocks providing 115mm deep by 304mm wide with a minimum height of 555mm. No part of the Pre-cast Flue must be less than 63mm.
- The Fire may be used in conjunction with a Fully Sealed Rebated 150C rated or Equivalent Purpose Built Fire Surround.
- Any Pre-Cast Flue must be Sound and Free from Obstructions (Mortar Fangs or Protrusions into the Flue Way) and have an effective height of over 3 meters.
- For Pre-cast Flues - ensure the walls are dry lined over the route of the flue and no dabs or battens are in direct contact with the flue blocks otherwise wall cracking will occur as detailed in BS 5440 Pt 1 2008.
- A Purpose Designed Flue Box to BS715 fitted with a 5" twin walled flue with a minimum effect height of 3 meters to BS EN 1856. Details are available from your authorised supplier.
- Ensure that only one fireplace is served by the flue system.
- Ensure that the chimney/flue is continuous from inlet to termination.
- Ensure that the chimney/flue is structurally sound, so that combustion products do NOT come into contact with combustible materials outside the chimney.
- CHECK FLUE PULL.** Apply a smoke match or smoke generator to the flue opening at hearth level and observe smoke. If there is a definite flow into the flue aperture, proceed with installation. If there is not a definite flow into the flue aperture, preheat the flue for approximately 10 minutes and re-test. If there is not a definite flow towards the flue aperture the flue may need attention.

DO NOT FIT THE APPLIANCE, SEEK EXPERT ADVICE.

10. - VENTILATION

- No additional purpose provided ventilation is normally required for the fire when installed in the UK; however this **must** be confirmed by the Spillage Test, see Section 18.2.
- For other Countries refer to National Regulations and Local Codes.
- This appliance is fitted with an oxygen depletion sensing system, which automatically shuts off the gas supply to the fire if the oxygen level in the room is depleted, due to lack of primary air, or obstructed flue that would lead to incomplete combustion of the gas. It **must not** be tampered with and only replaced with a genuine Nu-Flame ODS Pilot.

11. - GAS SUPPLY

It Is Recommended to Check The Next Section as Building Work May Affect the Gas Supply Routing.

- a. Carry out a gas soundness test before working on the gas supply.
- b. Gas supply provision should be made in accordance with the latest Gas Safety (Installation and Use) Regulations as amended.
- c. Confirm that the fire has been supplied for the correct gas to be used by checking the Data Badge in the base of the fire.
- d. A route for a concealed gas supply is provided through a hole in the rear of the fire, at a position of 95mm to the left of the centre of the fire and 49mm up from the base of the Fireplace/Builders opening. An isolation elbow is provided at the control inlet. Your 8mm gas supply pipe needs to protrude through the back of the convector box by approximately 105mm to achieve a neat connection onto the back of the isolator elbow on the burner. (This applies to All Control Options.)
- e. Where the gas supply passes through walls, floors, voids, concrete and wall cavities the supply should be sleeved.
- f. Determine the gas supply pipe size required taking into account any other gas appliances.
- g. Determine where the gas supply pipe needs to terminate and fit the 8mm compression isolation/pressure test elbow provided.
- h. In common with all other gas appliances, dirt and debris in the gas system can block the valve and gas injectors on this appliance, and faults caused by this are not covered by the guarantee.
Therefore it is important that all gas pipes **must** be purged of both air and debris.
- i. If you suspect that there may still be dirt and/or debris in the gas system, fit a filter in the pipeline, before the gas isolation/pressure test elbow.
- j. Do **not** use jointing compound on any compression fittings on the fire. The use of jointing compound on the compression joints on this appliance will possibly invalidate the guarantee, as it can get into the control mechanism and cause a malfunction.
- k. Seal off the isolation/pressure test elbow and check all gas connections for gas soundness before proceeding to fit the fire.

! IMPORTANT NOTE !

Always reseal the pressure test point and check that it is gas tight. (This accounts for a lot of recalls.)

***Sections 12 - 15 are for the various Installation Applications -
Only one will apply.***

***! IMPORTANT NOTE ! The chosen installation should have
been predetermined and arranged before installing the fire.***

Ensure you refer to the section relevant to your requirement.

The Installation Application Options Are:

- 12.0 Installation into a Class 1 or Lined Flue with a 150°C rated Fire Surround fitted into a Suitable Fireplace Opening or 16" Chairbrick.
- 13.0 Installation into a Pre-cast Flue Fireplace. (Rebated Fire Surround Rated 150°C or Purpose Built Surround Extension.)
- 14.0 Installation into a BS 715 Shallow Flue Box with Twin Wall 5" Flue, False Chimney Breast with either a 150°C rated Fire Surround or part way up the wall as a Hole in the Wall Installation with Slips & Shelf.
- 15.0 Installation into a Hole in the Wall application with a Class 1 or Lined Flue requiring a Purpose made Builders Opening.

12. CLASS 1 OR LINED FLUE FIRE SURROUND APPLICATION

FIREPLACE CONSTRUCTION

12.1 - FIRE SURROUND APPLICATIONS

Fireplace Minimum Requirements

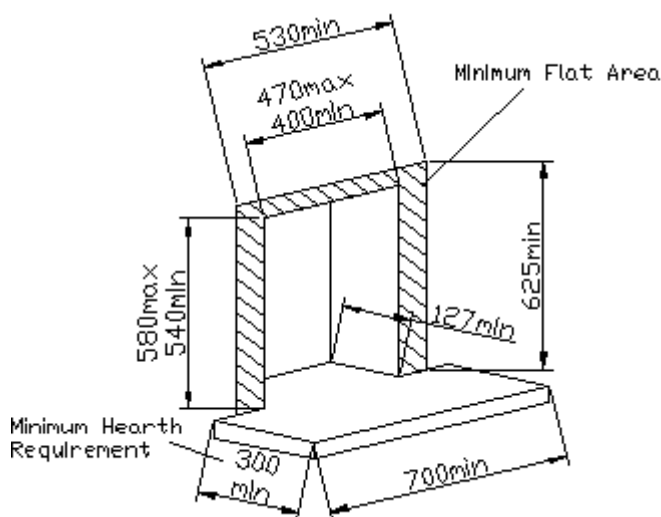

Fireplace Construction With 16" Chairbrick

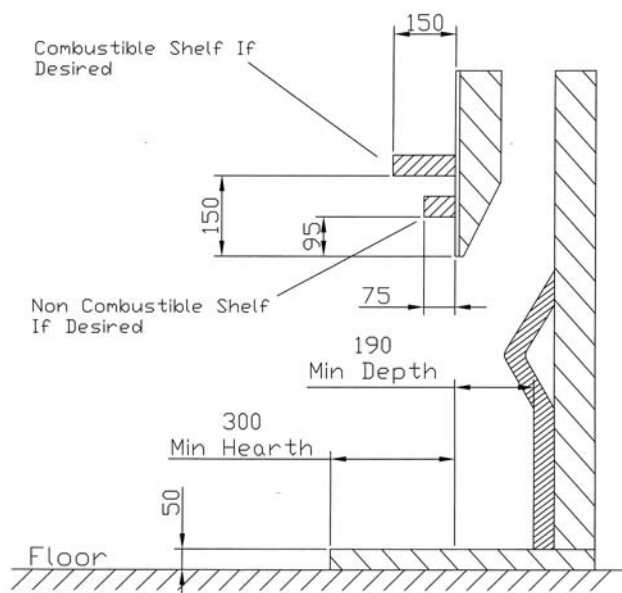

There must be no combustible materials inside the fireplace opening.

12.2 - FIRE SURROUND REQUIREMENTS (See diagram in Section 12.1)

- If the Fire is to be fitted into a purpose made Fire Surround it must have a temperature rating of 150°C.
- Where the depth available is greater than 127mm the minimum width can be reduced correspondingly to a minimum of 350mm.
- Where the fire is to be fitted into an existing 16" chairbrick a depth of 190mm is required to allow sufficient volume for Debris, if sufficient depth is not available the rear of the Chairbrick should be removed or extra depth added to the front.
- The Fire requires a non-combustible hearth of at least 12mm thick.
- The surface of the hearth must stand at least 50mm above the floor and level with the fireplace opening.
- The hearth must project at least 300mm in front of the fireplace opening and 150mm either side (700mm minimum hearth width).
- The base of the fireplace must be flat, level and square to the face of the fireplace opening.
- The Surround must cater for a minimum flat surface around the Fireplace Opening allowing 625mm high by 530mm wide. This is essential in order to achieve a good seal between the face of the surround and the sealing flanges of the fire.
- The Fire Surround must be fully sealed to the Fireplace Opening to ensure a good flue seal.
- The Fireplace Opening should have provision for a gas supply through the rear, see Section 11 Gas Supply.
- The High Level and Thermatronic Control Systems are fitted with Electronic Equipment, which is sensitive to dampness and high humidity so it is very **important** that any rendering/building work is allowed to thoroughly dry out before Installation.

! IMPORTANT NOTE ! Dry lined walls – ensure that any air gaps between the back of the plasterboard and wall are sealed around the builders opening or fireplace as this can affect flue pull and wall staining.

12.3 - CLEARANCES TO COMBUSTIBLE MATERIALS AND SHELVES (Ref: Diagram in Section 12.1)

- A **non combustible** shelf can be fitted above the fire and should be positioned at least 95mm above the builders opening. We recommend the depth of the shelf should be a maximum of 75mm as anything deeper will reduce convection air and the efficiency of the fire. For deeper non-combustible shelves they must be raised a further 25mm for every extra 25mm of depth.
- A 150mm **combustible** shelf can be fitted above the fire but must be positioned at least 150mm above the builders opening. For deeper combustible shelves they must be raised a further 25mm for every extra 25mm of depth.
- Any combustible sidewall must be at least 500mm from the inside of the builders/fireplace opening, however with a combustible fire surround it can be 150mm from the inside of the builders/fireplace opening provided it does not protrude more than 150mm and must be increased by 25mm for every extra 25mm of depth.
- With all heating appliances, soft furnishings, decorations and wall coverings may discolour or scorch if placed too close.
- No combustible material, e.g. curtains must be closer than 500mm to the builders opening.
- Any combustible wall claddings (wall paper) must be cut back to a height of 750mm and 300mm either side of the Fireplace Opening.
- Due to the heat output of The Slimline Radiant H.E. it is **not recommended** to use blown vinyl wall covering around the fire.

NOW PROCEED TO SECTION 16 - FIXING THE FIRE.

**13. INSTALLATION INTO A PRE-CAST FLUE
(Rebated Fire Surround Rated 150°C or Purpose Built Surround Extension)
FIREPLACE CONSTRUCTION**

13.1 - EXISTING MINIMUM PRE-CAST FLUE FIREPLACE REQUIREMENTS

! IMPORTANT NOTE ! THERE ARE NUMERIOUS DIFFERENT SIZES OF PRE-CAST FLUE FIREPLACES AND THE FOLLOWING DETERMINES THE MINIMUM REQUIREMENTS AND THE ADDITIONAL BUILDING WORK REQUIRED.

**Pre-Cast Fireplaces
Minimum Requirements**

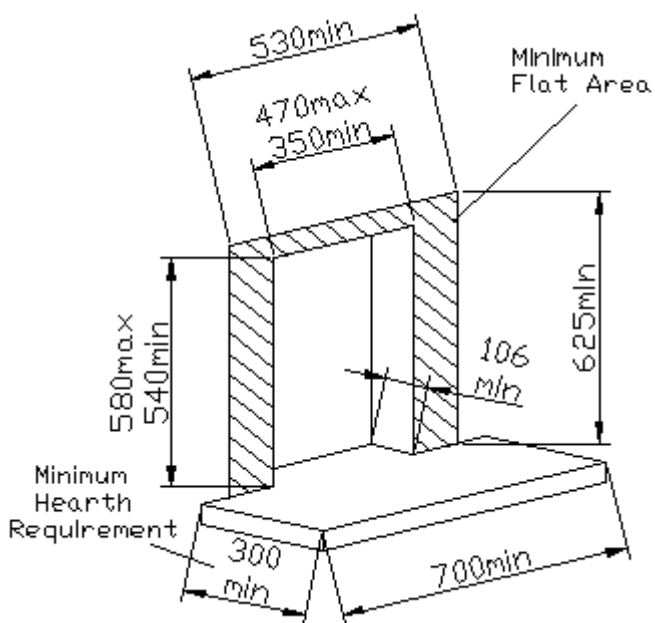

**Pre-Cast Flue Application
Rebated Fire Surround or
Equivalent**

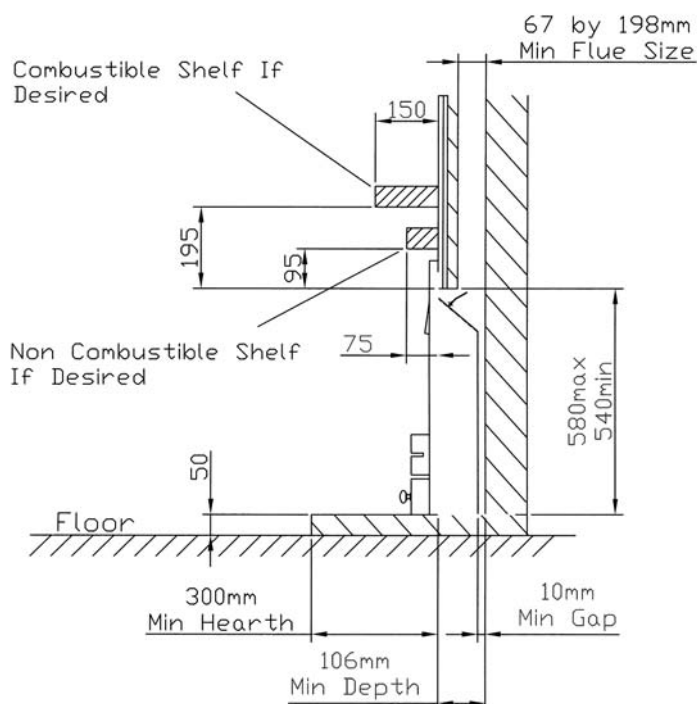

**Pre Cast Flue Fireplace
Depth Construction**

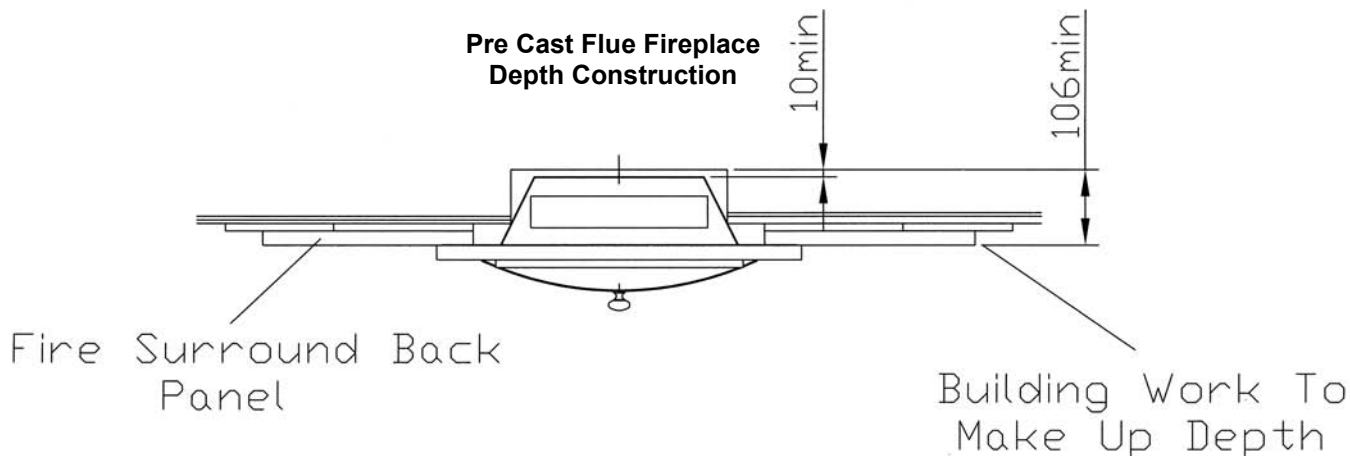

There must be no combustible materials inside the builders opening.

13.2 - FIREPLACE MINIMUM REQUIREMENTS (See diagram in Section 13.1)

With the Majority of Pre-Cast Flue Fireplaces there will be insufficient depth-width and building work with either a Purpose Made Non-Combustible Fire Surround or Rebated Fire Surround Will be Required to Create the Necessary Fireplace Prior to Installation.

Prior to any Building work and to provide adequate flow conditions to the flue, ensure the Minimum Pre-Cast Flue Requirements are available as detailed in a) & b), also make reference to the Diagrams.

- a. The Minimum Pre-cast Flue Size is 67mm deep by 198mm wide with Starter Blocks providing a Minimum Depth of 115mm by 305mm wide. No part of the Flue must be less than 63mm.
- b. The height of the Pre-cast Fireplace opening must be between 540mm and 580mm. If the Starter Blocks have not been provided down to Floor level then building work will be required.
- c. Where the Pre- cast Flue Fireplace with Starter Blocks provide less than the minimum depth of 106mm and width of 305mm a purpose built extension will be required. This Extension must be made of Non Combustible materials and fully sealed to the Existing Fireplace.
- d. The 106mm of depth required caters for a 10mm gap at the rear of the fire to allow for debris build-up.
- e. With the minimum depth it may be necessary to rebate/sink the Eye Bolts to prevent the heads fouling on the back of the fire. See Section 16.2 g.
- f. If the Fire is to be fitted with a purpose made Rebated Fire Surround it must have a temperature rating of 150°C.
- g. The Fire Surround must be fully sealed to the Fireplace Opening to ensure a good flue seal.
- h. The Fire requires a non-combustible hearth of at least 12mm thick.
- i. The surface of the hearth must stand at least 50mm above the floor and level with the fireplace opening.
- j. The hearth must project at least 300mm in front of the fireplace opening and 150mm either side (700mm minimum hearth width).
- k. The base of the fireplace must be flat, level and square to the face of the fireplace opening.
- l. The Surround must cater for a minimum flat surface around the Fireplace Opening allowing 625mm high by 530mm wide. This is essential in order to achieve a good seal between the face of the surround and the sealing flanges of the fire.
- m. The Fireplace Opening should have provision for a gas supply through the rear, see Section 11 Gas Supply.
- n. The High Level and Thermatronic control systems are fitted with Electronic Equipment, which is sensitive to dampness and high humidity so it is very **important** that any rendering/building work is allowed to thoroughly dry out before Installation.

! IMPORTANT NOTE ! Dry lined walls – ensure that any air gaps between the back of the plasterboard and wall are sealed around the builders opening or fireplace as this can affect flue pull and wall staining.

Pre-Cast Flues – ensure the walls are dry lined over the route of the flue and no dabs or battens are in direct contact with the flue blocks otherwise wall cracking will occur as detailed in BS 5440 Pt 1 2008.

13.3 - CLEARANCES TO COMBUSTIBLE MATERIALS AND SHELVES (Ref: Diagram in Section 13.1)

- a. A **non-combustible** shelf can be fitted above the fire and should be positioned at least 95mm above the builders opening. We recommend the depth of the shelf should be a maximum of 75mm as anything deeper will reduce convection air and the efficiency of the fire. For deeper non-combustible shelves they must be raised a further 25mm for every extra 25mm of depth.
- b. A 150mm **combustible** shelf can be fitted above the fire but must be positioned at least 150mm above the builders opening. For deeper combustible shelves they must be raised a further 25mm for every extra 25mm of depth.
- c. Any combustible sidewall must be at least 500mm from the inside of the builders/fireplace opening, however with a combustible fire surround it can be 150mm from the inside of the builders/fireplace opening provided it does not protrude more than 150mm and must be increased by 25mm for every extra 25mm of depth.
- d. With all heating appliances, soft furnishings, decorations and wall coverings may discolour or scorch if placed too close.
- e. No combustible material, e.g. curtains must be closer than 500mm to the builders opening.
- f. Any combustible wall claddings (wall paper) must be cut back to a height of 750mm and 300 mm either side of the Fireplace Opening.
- g. Due to the heat output of The Slimline Radiant H.E. it is **not recommended** to use blown vinyl wall covering around the fire.

NOW PROCEED TO SECTION 16 - FIXING THE FIRE.

14. BS715 SHALLOW FLUE BOX WITH TWIN WALL 5" FLUE – FALSE CHIMNEY BREAST CONSTRUCTION WITH FIRE SURROUND OR HOLE IN THE WALL APPLICATIONS

14.1 - FALSE CHIMNEY BREAST CONSTRUCTION

BS715 Shallow Flue Box Application

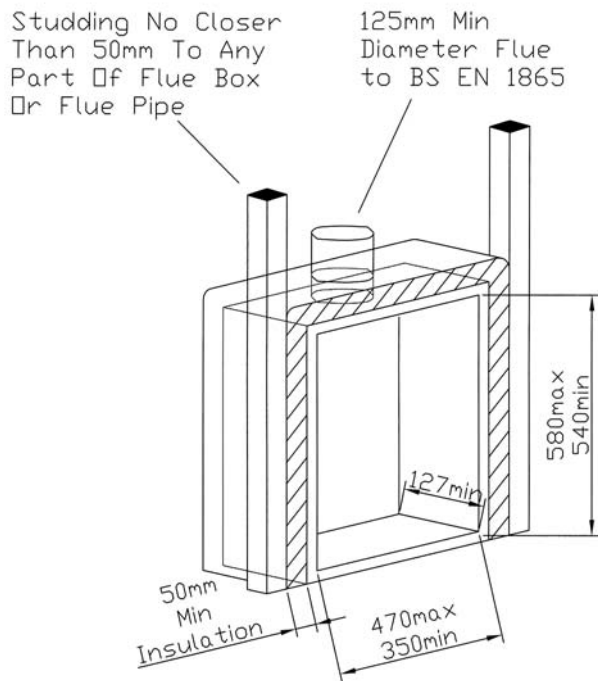

BS715 Flue Box Hole In The Wall Construction

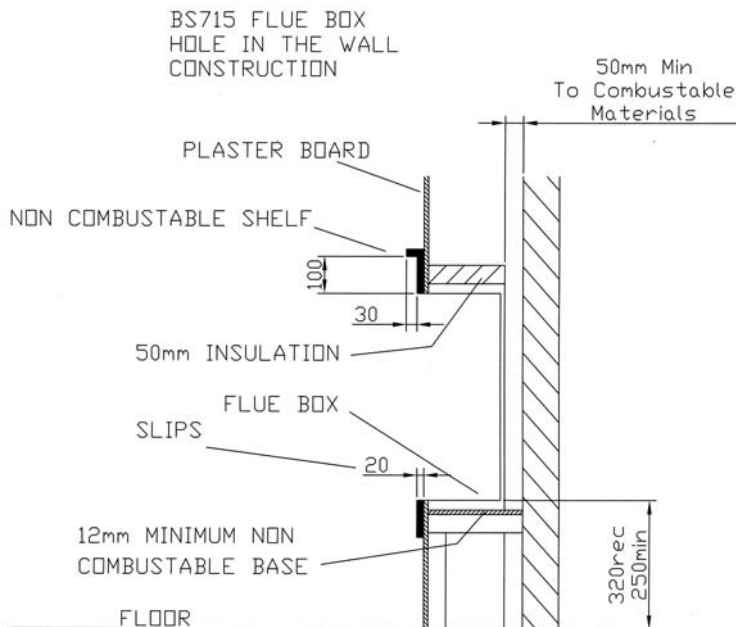

There must be no combustible materials used inside the flue box.

14.2 – BS 715 FLUE BOX BUILT INTO A FALSE CHIMNEY BREAST WITH FIRE SURROUND OR HOLE IN THE WALL INSTALLATION WITH REQUIREMENTS (See diagrams above).

A BS 715 Flue Box can be built into a false chimney breast and installed at floor level with a suitable Fire Surround.
or

The Fire can be Built-In part way up the wall to create a Hole in the Wall Installation, however it is essential to use marble, slate or stone slips, fitted around the builders opening. The slips must have a temperature rating of 150°C and be 20mm (min) thick by 100mm (min) wide.

In order to direct the flow of heated air away from the wall we recommend that a non combustible shelf (lip) is fitted above the top slip, protruding 30mm – see diagram.

For Hole in the Wall fires it is recommended that a means, (tactile separator/shelf or guard) is provided to give abrupt warning to a person moving inadvertently towards the fire.

- a. A suitable BS715 Shallow Flue Box should be used with the minimum dimensions quoted above.
- b. The base of the flue box must be level and square to the face of the fireplace opening.
- c. The Flue Box must sit on Non Combustible Material of at least 12mm Thick.
- d. The Flue Box can be placed against a Non Combustible wall at the rear, however if the wall is combustible it must be spaced 50mm from the wall.
- e. When building a False Chimney Breast No Combustible materials must be closer than 50mm to the Flue Box.
- f. No Combustible materials must be closer than 50mm to the Flue over its entire route through the Property.
- g. The Flue Box must be Insulated on its top and sides with 50mm thick Non Combustible Fibreglass Insulation or Equivalent.
- h. If plaster board is used in front of the flue box it must be sealed to the box with high temperature Silicone Sealant or an equivalent flexible sealant.
- i. If the Fire is to be fitted into a purpose made Fire Surround it must have a temperature rating of 150°C.
- j. For a Fire Surround the fire requires a non-combustible hearth of at least 12mm thick.
- k. The surface of the hearth must stand at least 50mm above the floor and level with the fireplace opening.
- l. The hearth must project at least 300mm in front of the fireplace opening and 150mm either side (700mm minimum hearth width).
- m. The Surround must cater for a minimum flat surface around the Fireplace Opening allowing 625mm high by 530mm wide. This is essential in order to achieve a good seal between the face of the surround and the sealing flanges of the fire.
- n. The Fire Surround must be fully sealed to the Fireplace Opening to ensure a good flue seal.
- o. In order to direct the flow of heated air away from the wall we recommend that a non combustible shelf (lip) is fitted above the top slip, protruding 30mm – see diagram in Section 14.1 on previous page.
- p. There must be a flat surface around the opening of sufficient area to enable the slips to be securely fitted. The slips should be fitted to the wall in such a way that they form a seal to stop air from the room being drawn behind the slips into the False Chimney Breast. We recommend a high temperature silicon sealant.

- q. The **recommended** height for the base of the Builders Opening is 320mm above floor level. The **minimum** height for the base of the Builders Opening is 250mm above floor level.
- r. The Fireplace Opening should have provision for a gas supply through the rear, see Section 11 Gas Supply.
- s. The High Level and Thermatronic control systems are fitted with Electronic Equipment, which is sensitive to dampness and high humidity so it is very **important** that any rendering/building work is allowed to thoroughly dry out before Installation.

! IMPORTANT NOTE ! Do not forget to take account of the difference in height of the base of the Flue Box when mounting the box on the floor; it must be level with the Hearth.

**14.3 - CLEARANCES TO COMBUSTIBLE MATERIALS AND SHELVES (Ref: Diagram on Previous Page)
The Requirement for Shelves for Hole in the Wall Installations is Detailed in the Above Section.**

- a. For Fire Surrounds a **non combustible** shelf can be fitted above the fire and should be positioned at least 95mm above the builders opening. We recommend the depth of the shelf should be a maximum of 75mm as anything deeper will reduce convection air and the efficiency of the fire. For deeper non-combustible shelves they must be raised a further 25mm for every extra 25mm of depth.
- b. For Fire Surrounds a 150mm **combustible** shelf can be fitted above the fire but must be positioned at least 195mm above the builders opening. For deeper combustible shelves they must be raised a further 25mm for every extra 25mm of depth.
- c. Any combustible sidewall must be at least 500mm from the inside of the builders/fireplace opening, however with a combustible fire surround it can be 150mm from the inside of the builders/fireplace opening provided it does not protrude more than 150mm and this must be increased by 25mm for every extra 25mm of depth.
- d. With all heating appliances, soft furnishings, decorations and wall coverings may discolour or scorch if placed too close.
- e. No combustible material, e.g. curtains must be closer than 500mm to the builders opening.
- f. Any combustible wall claddings (wall paper) must be cut back to a height of 750mm and 300 mm either side of the Fireplace Opening.
- g. Due to the heat output of The Slimline Radiant H.E. it is **not recommended** to use blown vinyl wall covering around the fire.

NOW PROCEED TO SECTION 16 - FIXING THE FIRE.

15. HOLE IN THE WALL APPLICATIONS INTO CLASS 1 or LINED FLUE BUILDERS OPENING

15.1 - SLIPS & WALL COVERINGS

It is essential to use marble, slate or stone slips, fitted around the builders opening. The slips must have a temperature rating of 150°C and be 20mm (min) thick and typically form a border round the opening of 100mm. In order to direct the flow of heated air away from the wall we recommend that a non combustible shelf (lip) is fitted above the top slip, protruding 30mm beyond the front face of the slip – see diagram in Section 15.3 on the following page.

With any form of heating appliance convection air will rise up through the fire carrying particles of dust that will in time result in varying degrees of wall staining. The non-combustible shelf is designed to minimise this by deflecting the airflow away from the wall. However, over time some staining might occur and we therefore suggest not using patterned paper around the fire.

Due to the heat output of The Slimline Radiant H.E. it is **not recommended** to use blown vinyl wall covering around the fire.

Where the Chimney Breast is made of Stone or Slate or other Suitable Non Combustible Material with NO wall coverings then Slips are Not Required but the Dimensions of the Builders Opening must be as shown below and a Flat Surface of at least 65mm must be provided around the opening for sealing.

For Hole in the Wall fires it is recommended that a means (tactile separator/shelf or guard) is provided to give abrupt warning to a person moving inadvertently towards the fire.

15.2 - HOLE IN THE WALL APPLICATION (USING MARBLE SLATE OR STONE SLIPS & SHELF)

Builders Opening for Hole in the Wall application (when using marble, slate or stone slips)

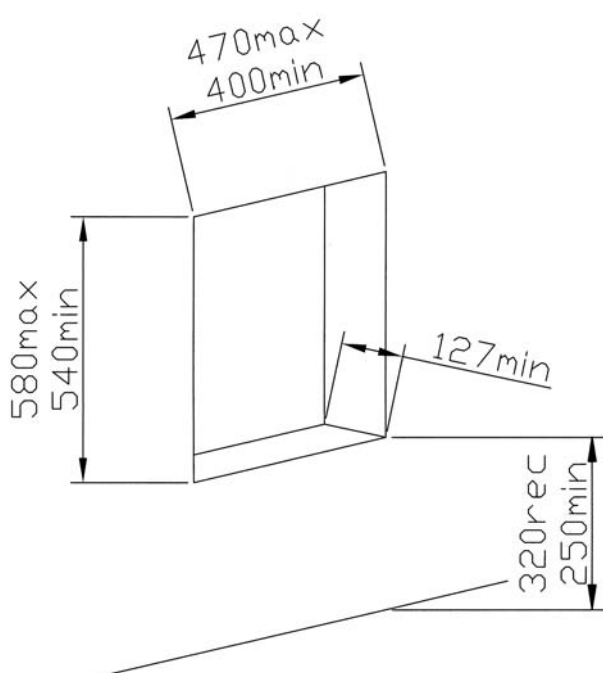

- It is recommended that a qualified builder constructs the builders opening.
- It is recommended that a lintel is fitted above the builders opening.
- The builders opening must be constructed from Non-combustible materials.
- No** combustible materials must be present in the builders opening.
- The base of the builders opening must be flat, level and square to the wall and be at least 12mm thick.
- The builders opening should have provision for a gas supply through the rear, see Section 11 Gas Supply.
- There must be a flat surface around the builders opening of sufficient area to enable the slips to be securely fitted. The slips should be fitted to the wall in such a way that they form a seal to stop air from the room being drawn behind the slips into the builders opening. We recommend a high temperature silicon sealant.
- The **recommended** height for the base of the Builders Opening is 320mm above floor level. The **minimum** height for the base of the Builders Opening is 250mm above floor level.
- High Level and Thermatronic controlled models are fitted with Electronic Equipment, which are sensitive to dampness and high humidity so it is very **important** that any rendering/ building work is allowed to thoroughly dry out before Installation.

IMPORTANT NOTE !

Dry lined walls – ensure that any air gaps between the back of the plasterboard and wall are sealed around the builders opening or fireplace as this can affect flue pull and wall staining.

Hole in the Wall Installation into Class 1 or Lined Flue

15.3 - CLEARANCES TO COMBUSTIBLE MATERIALS

- Any combustible sidewall must be at least 500mm from the inside of the builders/fireplace opening.
- With all heating appliances, soft furnishings, decorations and wall coverings may discolour or scorch if placed too close.
- No combustible material, e.g. curtains must be closer than 500mm to the builders opening.

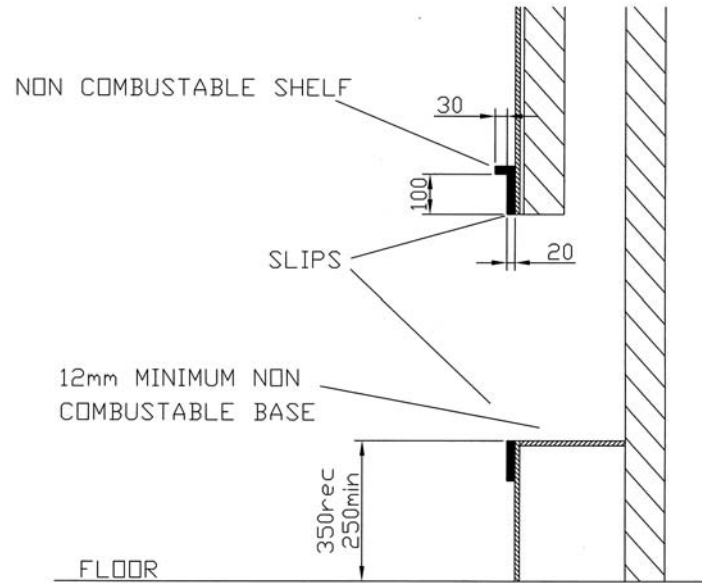

NOW PROCEED TO SECTION 16 - FIXING THE FIRE.

16. FIXING THE FIRE

16.1 - FITTING THE SILICONE SEALING STRIP

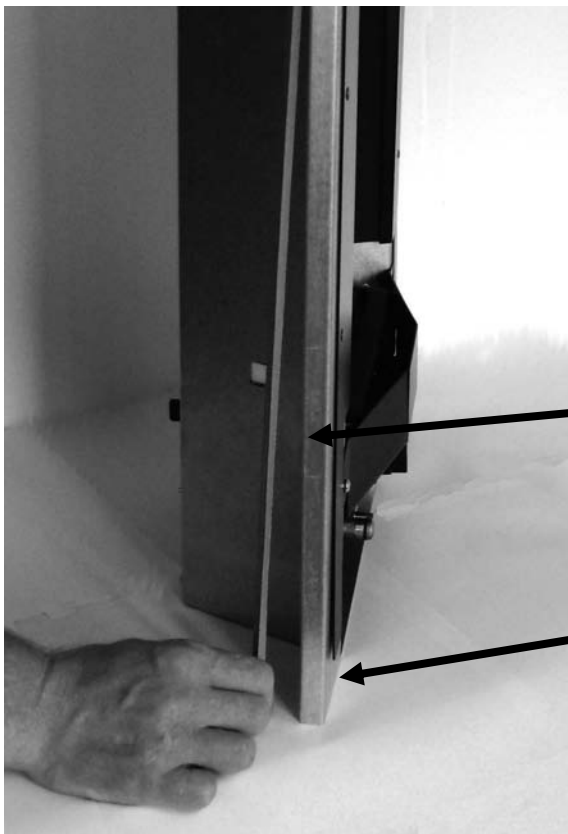

It is very important that a good seal is achieved between the back of the Fire's outer frame and the front of the fireplace back panel for safety reasons and to achieve maximum efficiency. Take the self adhesive silicone sealing strip from the fitting kit and neatly apply to the back flanges of the Fire's outer frame, cutting to the appropriate lengths as required. To ensure there is a good seal between the base of the fire and the bottom of the fireplace opening apply a 350mm length of self adhesive silicone sealing strip under the base of the fire at the front edge.

Fit Silicone Sealing Strip to back flanges of outer frame

Fit 350mm length of Silicone Sealing Strip under the base of the fire at the front edge

16.2 - FITTING THE FIRE - references should be made to the drawings overleaf.

! IMPORTANT NOTE ! TAKE GREAT CARE WHEN WORKING INSIDE THE FIRE NOT TO MARK THE CERAMIC LINING PANELS.

- a. Using a Dust Sheet or equivalent protect the area around the Fire Installation.
- b. Remove the Fire from the box and lay it on its back.
- c. With the High Level and Thermatronic Control Systems remove the Control Heat Shield, which is secured with a single screw at the base of the fire on the left side.
- d. Now remove the Burner/Control Assembly by removing the 2 screws at the front of the fire taking care not to mark the liners. Slide the Burner Assembly forward and if the fire is fitted with the High Level or Thermatronic Control it will also be necessary to carefully slide out the Battery/Receiver Box and, in the case of the Thermatronic Control, carefully pull the Infrared Sensor off its Velcro Pad.
- e. Remove the Debris Plate at the back by removing the 4 screws allowing access through the Debris Opening for fitting the Gas Supply.
- f. There are fixing holes in the front flanges which can be used if there is sufficient strong material for fixing, however we recommend the cable fixing system which is supplied to secure the unit into the fireplace. The cable fixing system will also pull the unit tight back into the fireplace to make a good seal. This is very important to ensure efficient and safe operation of the fire.
- g. There are a number of options for the Cable fixing system in different installation applications therefore please read the options first before proceeding.
 - i. For Builders Opening applications and with reference to the diagram overleaf use the 2 cables supplied; 1 to be used each side of the unit. Working 27mm up from the base of the Builders Opening and at 200mm centres drill the lower holes and then at 455mm up from the base but at 250mm centres drill the upper holes. Secure the 4 Eyebolts supplied with the Raw plugs to the back of the fireplace.
 - ii. For Pre-cast Flue applications where the minimum depth is found it may be necessary to sink/rebate the Eye Bolts to ensure the heads do not foul on the back of the fire.
 - iii. For Chairbrick applications and to prevent the cables fouling on the Knee of the Chairbrick the Upper Eye Bolts should be secured to the side walls of the Chairbrick. Positioned at same height as the standard option above but with the upper eye bolts 100mm in from the front. See Diagrams below and on next page.

IMPORTANT: ENSURE THE MATERIAL THE EYEBOLT/RAWPLUG IS FIXED INTO IS SOLID AND SOUND. If the fixing is not sound the Rawplug/Eyebolt will be pulled out and the fire will not be sealed to the Fireplace Opening.

Note: With the minimum depth fireplace enclosure it may be necessary to sink the Eye Bolt Heads into the Brickwork.

- h. With the Eye Bolts now in position there are 2 cable attachment tabs on the top of the main casing; 1 each side at the rear. Feed a cable outward through each cable attachment point.
- i. Feed the cables through the eyebolts on either side and then through the holes in the back of the fire near the base.
- j. Slide the Fire **part way** into the fireplace (leaving it sticking out approximately 50mm) ensuring the gas supply pipe and isolation/pressure test elbow clears through the Debris Opening in the rear of the Fire.
- k. Slide the Fire fully home ensuring that the sealing strips on the rear of the Fire outer frame stay in position to make a seal against the fireplace back panel. While sliding the unit into the fireplace opening pull on the excess cable.
- l. Locate the supply pipe into the slot in the Debris Opening and replace the Debris Plate.
- m. The Cable Fix Adjuster and Lock Screw can now be fitted onto the cable and tightened up to tension the fire back into the fireplace. The fire should be secure and not liable to movement.

Surplus fixing cable MUST NOT be cut off and must be tucked back through the central hole in the Back of the Fire. This is particularly important with the Electronic Control Systems to keep the cables away from any electronics.
- n. If any of the silicone sealing strips are not compressed and/or if there are gaps they must be filled with a suitable sealant, ideally high temperature silicone or fireclay. If any of the silicone sealing strips are not compressed and/or if there are gaps they must be filled with a suitable sealant, ideally high temperature silicone or fireclay. Refit the Burner/Controls Assembly with the 2 screws and with the High Level and Thermatronic Control System refit the Battery/Receiver Box at the left hand side, and then, for the Thermatronic, secure the Infrared Sensor onto the Velcro Pad. Then refit the Heat Shield above the Battery/Receiver Box and secure with the screw removed earlier.

Important: Ensure the Red Bulb on the Thermatronic Infrared Sensor is facing Forward.
Important: Ensure the Heat Shield has been fitted with the High Level and Thermatronic Control Systems.
- o. Connect the isolation/pressure test elbow to the control valve and with it fully open check the joint for gas soundness.
- p. Check that all gas connections are sound. The appliance has been factory tested; however the connections may have been disturbed in transit or storage.

! TIP ! Ensure the Red Bulb on the Infrared Sensor is facing Forward as this can prevent the Handset from working.

! IMPORTANT NOTE ! Always reseal the pressure test point and check that it is gas tight. (This accounts for a lot of recalls.)

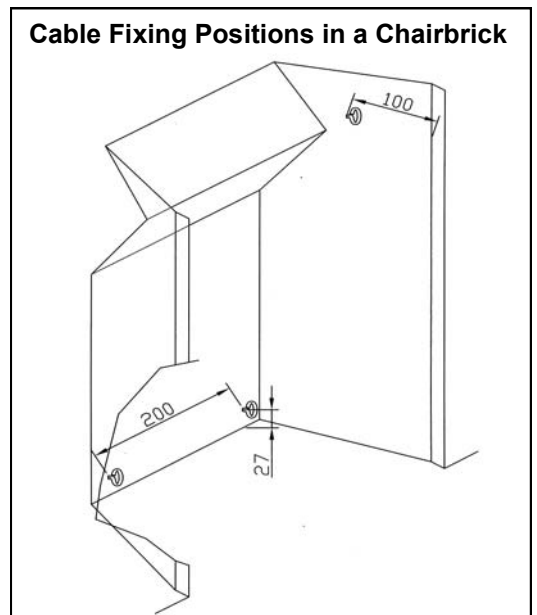

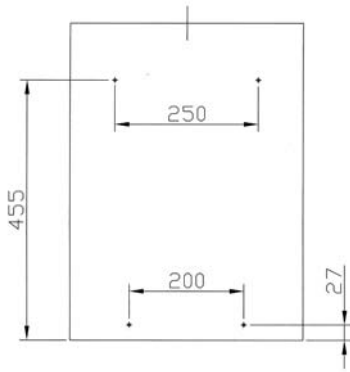

Hole Positions in back of Fireplace Opening

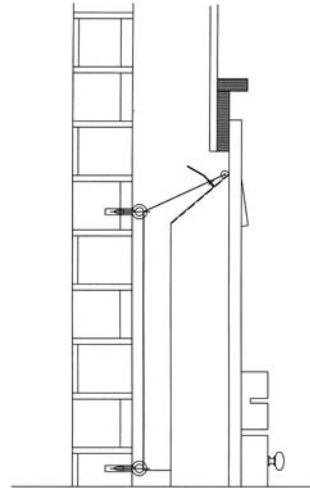

Side View of Cable Fixing System

17. - ARRANGEMENT OF THE FUEL EFFECT (COALS or PEBBLES as Ordered).

Remove all the Fuel Effect parts, you will see there are different sizes and shapes of either Coals or Pebbles, with 2 halves of a Matrix. Refer to the Coals or Pebbles diagrams.

! TIP ! Take care not to damage liner panels.

- a. Fit the 2 parts that form the Matrix. You may notice small white marks on the Matrix. This is part of the production process.



! TIP ! Pebbles only The Long Pebbles are marked Nos.3-7 for identification and have different textures and colours. All the Large Pebbles are Marked No. 1 and all the Small Pebbles are marked No.2. Both Large and Small Pebbles have different textures and colours

- b. **For Coals Layout**
Fit 2 Large Coals at the Rear of the Fire.
For Pebbles Layout
Choosing different textures and colours fit 2 large Pebbles at the rear of the Fire.



! TIP ! When fitting the Coals/Pebbles leave gaps between as this helps achieve the best effect.

- c. **For Coals Layout**
Fit 2 Small 'C' Coals, 1 to the far left corner and 1 to the far right corner of those fitted in b.
For Pebbles Layout
Choosing different textures and colours, fit 2 Small Pebbles, 1 to the far left corner and 1 to the far right corner of those fitted in b.



d. For Coals Layout

Fit 2 Triangular Coals in the Front Left and Right Corners of the Matrix.

For Pebbles Layout

Fit 2 Long Pebbles No.3 & No.7 in the Front Left and Right Corners.



e. For Coals Layout

Fit 3 Triangular Coals along the Front of the Matrix.

For Pebbles Layout

Fit 3 Long Pebbles Nos. 4, 5 & 6 along the Front of the Matrix, with their narrow ends inward.



f. For Coals Layout

Fit 1 Large Coal in the Centre of the Fuel Bed.

For Pebbles Layout

Fit 1 Large Pebble in the Centre of the Fuel Bed.



g. For Coals Layout

Fit 4 Small 'C' Coals, 2 either side of the Large Coal.

For Pebbles Layout

Fit 4 Small Pebbles, 2 either side of the Large Pebble.



h. For Coals Layout

Fit 2 Small 'C' Coals at the back of the Fuel Bed resting against the back.

For Pebbles Layout

Fit the remaining 2 Small Pebbles at the back of the Fuel Bed resting against the back.



You may now wish to exchange the different pebbles to achieve a better balance of textures and colours.

i. Once the fire is first lit it may be necessary to adjust some of the Coals/Pebbles to improve the effect.

j. When first lit the flames will be quite tall and yellow; this is quite normal as production process materials are burnt off.

18. - TESTING, COMMISSIONING & USE

- ! IMPORTANT NOTE !** During its first period of use any protective coatings and oils will burn out of the fire and it is wise to ventilate the room for the first hour; also advise the customer that this may persist for the first few days until the fire is fully burnt-in.

18.1 - LIGHTING THE FIRE

- Reference to Section 2 in the Users Instructions 'Lighting & Controlling the Fire' will show how to light and operate the fire.
- Check that the supply pressure to the fire is at the pressures required, 20mbar Natural Gas G20 when set at high.

- ! IMPORTANT NOTE !** Ensure that the pressure test point used is sealed and gas tight.

18.2 - TESTING FOR SPILLAGE

- A restrictor is supplied with the fire for flues that have an effective height greater than 3 meters. **The restrictor must not be fitted to Pre-cast Flue applications.** The restrictor is fitted over the outlet duct on the inside of the fire with the 2 # No8 x 10mm pointed self tapping screws provided, see below.

Without Restrictor

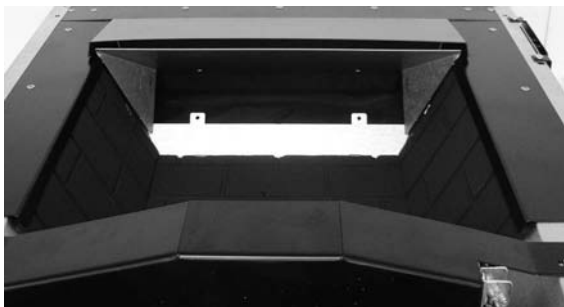

With Restrictor Fitted

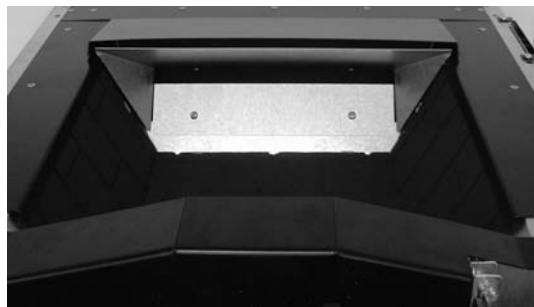

- Once the fire is operational the installer must check for spillage. Close all doors and windows. Carry out the lighting procedure and turn the fire to high. Allow to warm up for 5 minutes and then using a lit smoke match, joss stick or similar, place centrally just under the edge of the canopy as shown below. The majority of the smoke must be drawn under the Fire Canopy. Some small whiffs of smoke may be expelled and this is quite normal. Be careful not to introduce too much smoke (i.e. by using a pellet). A smoke match tube can be used to make holding of the match easier. See following diagram.

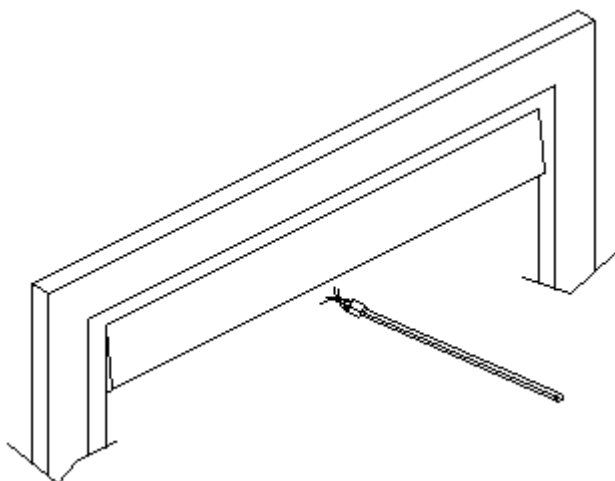

- Repeat the test with doors and windows to the premises/room both open and closed, and with any extractor fans in the same room or adjacent rooms running at high. The fire should continue to clear its combustion products. Also operate any other flued appliance in the same or neighbouring rooms and ensure they continue to function satisfactorily as multiple flues can work against one another.
- If spillage is detected during this procedure, remove the restrictor if fitted and repeat the tests.
- If spillage is detected and no restrictor is fitted, let the fire operate for a further 10 minutes and re-check.
- If the fire continues to spill, it could indicate a faulty flue or lack of ventilation. If the problem cannot be rectified immediately, disconnect the fire, affix a label and advise the customer not to use it until the problem has been resolved.
- It is an offence to use or allow the use of a dangerous appliance.**

18.3 - FITTING THE OUTER TRIM

- a. The Outer Trim is held in place with 4 strong Magnets, one at each corner, ensure they are in place. With Profile Frames the Magnets must be on the metal corner plates.
- b. To fit simply centralize the Trim and fit it onto the Fire. Note : If the Trim is not positioned centrally it may not be held correctly at each corner, however it can be slid from side to side to ensure it is located correctly.

NOTE for Trim Variants: Various Trim Options are available some have integral Frets and others are supplied with Separate Cast Frets. In all cases the Outer Frame is held as detailed above.

18.4 - FIREGUARDS

- a. A fireguard is not supplied with the appliance however it is recommended that a fireguard conforming to BS 7977 is fitted if the fire is to be used in the presence of young children, the elderly, the infirm and pets.
- b. For Hole in the Wall fires it is recommended that a means, (tactile separator/shelf or guard) is provided to give abrupt warning to a person moving inadvertently towards the fire.

19 - BRIEFING THE CUSTOMER

- a. The installer should brief the customer on the Operation of the Control System fitted (specifically the position for viewing the pilot for lighting, when applicable); operation of the Coal-Coke System (if applicable) and all aspects of the User Instructions.
- b. The instructions should be handed to the customer for their safe keeping and future servicing.
- c. For Customers who have purchased either of the 2 or 3 Button High Level Control explain and demonstrate that the batteries should be replaced with good quality batteries annually as the side switch may stop working part way through a season.
- d. For Customers who have purchased the Thermatronic Control explain and demonstrate that the batteries in the receiver and Handset should be replaced with good quality ones annually as the fire may stop working part way through the season.
- e. The customer should be briefed on the need for regular servicing; this will normally be once a year.
- f. Advise the customer that, apart from batteries for the High Level and Thermatronic Systems, there are no user replaceable parts in the fire but for servicing and spares to contact the local Nu-Flame Stockist.

20 - SERVICING

The Matrix in the fire is a Moulded Ceramic Fibre component incorporating Silicone Binders and you may notice that it develops cracks during operation. This is natural shrinkage caused by exposure to high temperatures and is quite normal for the material and will in no way affect the operation of the fire.

20.1 - GENERAL

Note: Servicing must be carried out by a registered installer.

- a. The fire does not have to be removed for Servicing.
- b. Check the operation and ignition of the fire before servicing.
- c. Ensure the fire is cold before proceeding.
- d. Lay a dust sheet on the floor before proceeding.
- e. Carry out a gas soundness test before servicing.
- f. Taking great care not to mark the liners, remove the Ceramic Coals or Pebbles and the Matrix. (The presence of white marks and/or surface cracking/crazing on the matrix is quite normal.)
- g. Pull off the Outer Trim/Frame, (Locate the 4 magnets), and turn off the gas supply to the fire at the isolation/pressure test elbow.
- h. If any parts need replacement, use only genuine parts supplied by Nu-Flame Ltd. Some components may look similar to those used in other gas fire, but these are not necessarily the same due to performance variations and must not be used.

This applies particularly to the ODS Pilot, Gas Control System and Ceramics.

- i. Disconnect the gas pipe to the control.

! TIP ! Being Magnetic The 4 Trim Magnets can be easily misplaced,. Locate them immediately.

20.2 - ANNUAL SERVICING

Carry out the operations in 20.1 General before proceeding

! IMPORTANT NOTE ! TAKE GREAT CARE WHEN WORKING INSIDE THE FIRE NOT TO MARK THE CERAMIC LINING PANELS.

- a. Referring to the Section 17, 'Arrangement of the Fuel Effect' and working in reverse order, remove the Coals or Pebbles and the Matrix. (The presence of white marks and/or surface cracking/crazing on the matrix is quite normal.)
- b. With the High Level and Thermatronic Control Systems remove the Control Heat Shield, which is secured with a single screw at the base of the fire on the left side.
- c. Now remove the Burner/Control Assembly by removing the 2 screws at the front of the fire taking care not to mark the liners. Slide the Burner Assembly forward and if the fire is fitted with the High Level or Thermatronic Control it will also be necessary to carefully slide out the Battery/Receiver Box and, in the case of the Thermatronic Control, carefully pull the Infrared Sensor off its Velcro Pad. This will now allow access to all gas carrying parts for maintenance checks, fault finding and or replacement.

Take care when removing the Burner - DO NOT lift it out holding the Burner Top

- d. Remove the Debris Plate by removing the 4 screws allowing access through the Debris Opening and clear away any Debris.
- e. Brush clean the burner and pilot area of dust or debris; check that the aeration hole in the pilot is clear of dust, fluff, lint.
- f. Refit in reverse order; brushing the coals/pebbles clean of any soot, checking gas soundness, ignition and spillage as detailed in the relevant sections.

ALWAYS CONDUCT A GAS SOUNDNESS AND SPILLAGE CHECK AFTER SERVICING.

ALWAYS RESEAL THE PRESSURE TEST POINT AND CHECK THAT IT IS GAS TIGHT. (This accounts for a lot of recalls.)

ALWAYS CHECK THAT THE CONTROL SYSTEM IS WORKING CORRECTLY. (This accounts for a lot of recalls.)

21 - FAULT FINDING GUIDE, SYMPTOMS AND POSSIBLE CAUSES

Important : In instances where it is indicating that the main control system needs changing, (specifically the 3 Button High Level or Thermatronic Control Systems), you should investigate returning the whole Burner Control Assembly to Nu-Flame for rectification as this could be the least cost option.

- a. Prior to any Servicing ensure that you have carried out the procedures in Section 20.1 General (Servicing).
- b. Check the supply pressure at the isolation elbow.
- c. **Important :** With the High Level and Thermatronic Systems always change the batteries before carrying out any Fault Finding

21.1 - RESETTING THE ELECTRONIC CONTROL (Applies Only to Thermatronic RF System Only)

Full Reset - If a new handset is obtained the control system will need to learn the handset's unique code via a Full Reset. Also, if the fire is not working and the Basic Reset (described on page 6) has not worked a Full Reset can be carried out:

- a. Remove the Ash Pan Cover and locate the electronic Receiver Box.
- b. Locate the Reset Hole on the side of the Receiver and using a pen press and hold in the Reset button until you hear two beeps.
- c. The first beep is short and the second beep is long. After the second beep release the Reset Button.
- d. Now on the Handset, within the next 20 seconds press and hold the Small Flame Button until you hear two additional short beeps confirming the code is set in the Receiver.
- e. If you hear one long beep the Code as not been set so repeat the procedure.
- f. If the Handset still does not work check the wiring and or replace the Receiver and Handset .

21.2 - NO SPARK IGNITION

- a. Replace the batteries in the Receiver and Handset (The 3 Button High Level Switch as Receiver Batteries only).
- b. Check there is no dust/debris shorting out the electrode or blocking gas from the pilot.
- c. Check the condition of the Ignition lead and ensure it is connected to both the ignition electrode and /or High Level Control or receiver. Check that the Ignition lead is not trapped and or shorting, replace if required. For the Manual System this will involve a new control. For the High Level Control an the Thermatronic System a separate ignition lead is available.
- d. Check that gas is flowing from the pilot during the ignition sequence. Clean or Replace as required.
- e. For the 3 Button High Level Control & Thermatronic Radio Frequency versions only, listen to the control to hear if the pilot gas solenoid is opening. Change the Receiver and High Level Switch or the Handset (which ever applies) at the same time and/or gas control. Refer to Diagram for Cable connections in Section 22.

21.3 - PILOT GOES OUT AFTER FIRST LIGHTING

- a. Check there is no debris blocking the flame to the thermocouple.
- b. Check the thermocouple is tightly connected to the control.
- c. Change the pilot assembly as a new thermocouple may be required.
- d. With the Manual System or 2 Button High Level Control change the Controls.
- e. For the 3 Button High Level Control & Thermatronic Radio Frequency versions only, listen to the control to hear if the pilot gas solenoid is opening. Change the Receiver and High Level Switch or the Handset (which ever applies) at the same time and/or gas control. Refer to Diagram for Cable connections in Section 22.
- f. Also see Section 21.4

21.4 - PILOT LIGHTS BUT MAIN BURNER DOES NOT LIGHT

- a. With All Control Systems listen to hear if gas is flowing into the main burner.
- b. Check there is no dust or debris blocking the flame from the pilot to the main burner.
- c. With the 2 Button High Level Control check that both Control Knobs are in the on position, fully turned anti clockwise. Also check 'e' before determining the action required.
- d. With the 3 Button High Level & Thermatronic System check if the main control knob on the control is turning to the high setting and listen to hear if the valve is opening. If not change the Handset & Switch (which ever applies) and at the same time the gas control.
For removal of the 3 Button Switch refer to 'f' and also refer to the Diagram for Cable connections in Section 22.
Also check 'g' (below) before considering replacing any parts. You should also consider the **Important** note in 21.1.
- e. With the 2 Button High Level Control it is possible for the Main Burner to light when first lit after lighting the Pilot but then the Push Buttons do not operate the control. Operate the bottom button and listen to see if the Control Knob turns. If it does not then change the batteries, if still a problem change the Switch Assembly as detailed in 'f'.
- f. For removal/replacement of the 2 & 3 Button Switches first remove the 2 screws retaining the Switch Shield, remove the 2 screws retaining the Switch Assembly. Disconnect the push on wire connections at the control. Remove the switch and wires and replace with a new component in reverse order.
- g. All Control Systems have a Pressure Test Point to allow the Burner Pressure to be checked to confirm if gas is flowing from the control. On the Manual Control it is visible at the front left of the control. On the High Level Controls it is on the left of the control and on the Thermatronic it is at the front of the Control and is the left/rear Pressure Test Point.
- h. Check if the main injector is blocked. Clean or Replace.

21.5 - PILOT FLAME SHORTENS, OR GOES OUT WHEN MAIN BURNER IS SELECTED

- a. Monitor the supply pressure at the isolation elbow as the main burner lights. If pressure drops, check gas pipe sizing, quality of pipe bending. Check for debris in the gas supply and or gas filter if fitted.
- b. Check that another appliance is not affecting the gas supply pressure.

21.6 - POOR FLAME PICTURE

- a. Check the supply pressure is correct at the isolation elbow. If the pressure is low, check gas pipe sizing, quality of pipe bending. Check for debris in the gas supply and or gas filter if fitted.
- b. All Control Systems have a pressure point to allow the Burner Pressure to be checked. On the Manual Control it is visible at the front left of the control. On High Level Control it is on the left of the control and on the Thermatronic it is at the front of the Control and is the left/rear Pressure Test Point. You may wish to check 'c' first.
- c. With the High Level Controls check the Buttons are operating correctly see Sections 21.3 & 21.4.
- d. Check that another appliance is not affecting the gas supply pressure.
- e. Check there is not a flue/ventilation problem – carry out a spillage test.
- f. Check fuel bed layout as detailed in Section 17.

21.7 - FIRE OPERATES FOR A WHILE THEN GOES OUT

- a. Check the supply pressure is correct at the isolation elbow with all other gas appliances working. If the pressure is low or fluctuating up and down check gas pipe sizing, quality of pipe bending. Check for debris in the gas supply, pilot pipe and or gas filter if fitted.
- b. Carry out a spillage test from cold. Look for signs of Discoloured Walls or Trims as this may be an indication of a Downdraught Problem.
- c. Establish how long the fire stays alight then repeat the Spillage Test around this time.
- d. For the Thermatronic System check that the Control is functioning correctly as detailed in Section 21.2 specifically the Thermocouple Electrical Connections and Pilot Flame size.
Downdraught problems can be related to the condition of the flue, chimney termination or geographical location; so if a Flue Problem is thought likely but no problem is found during the investigation isolate the fire and seek expert advice.

21.8 - THERMATRONIC RADIOA FREQUENCY CONTROL SYSTEM DOES NOT OPERATE

- a. Check the Control is being operated correctly - see Section 2.2
- b. Check for error messages and check batteries - see Section 2.3
- c. Reset the Mertik Maxitrol Logic Circuits - see Section 21.1

21.9 - HIGH LEVEL PUSH BUTTON CONTROLS DO NOT OPERATE

- a. Change the batteries then see if the push buttons now operate.
- b. The Switch and Receiver/Battery Box should be replaced.

Important : In instances where it is indicating that the main control system needs changing, (specifically the 3 Button High Level or Thermatronic Control Systems), you should investigate returning the whole Burner Control Assembly to Nu-Flame for rectification as this could be the least cost option.

ALWAYS CONDUCT A GAS SOUNDNESS AND SPILLAGE CHECK AFTER SERVICING.

ALWAYS RESEAL THE PRESSURE TEST POINTS YOU HAVE USED AND CHECK THAT THEY ARE GAS TIGHT.
(This accounts for a lot of recalls.)

ALWAYS CHECK THAT THE CONTROL SYSTEM IS WORKING CORRECTLY. (This accounts for a lot of recalls.)

MERTIK MAXITROL

© 2008 Mertik Maxitrol

GV60 and Mertik Maxitrol Cables with Layout Options

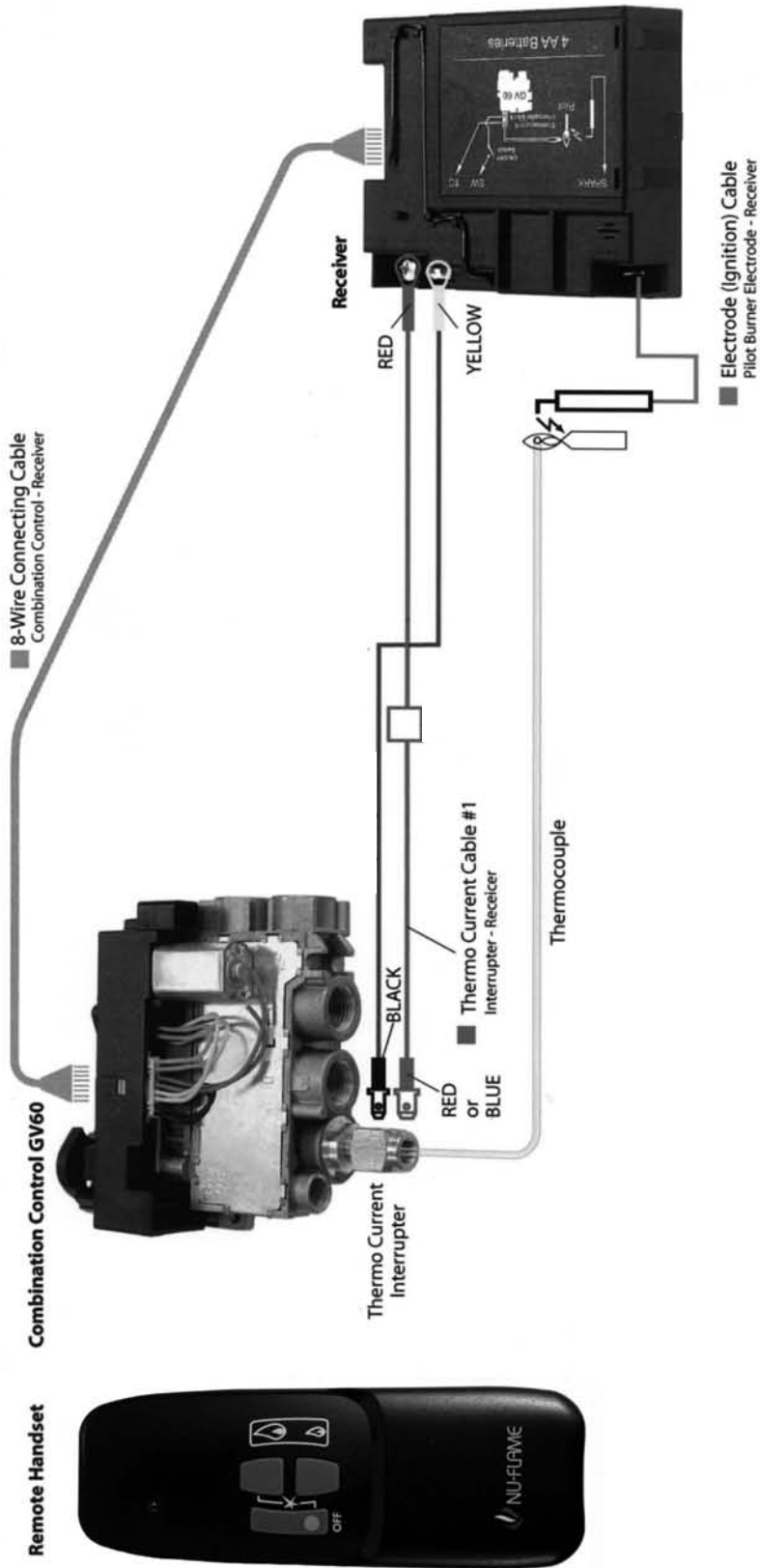



Telephone 020 8254 6802

Nu-Flame Warranty and Repair Procedure for The Slimline Radiant H.E

The Nu-Flame Slimline Radiant H.E. is guaranteed for 1 year from the date of purchase. During that time our guarantee is to send replacement parts for a fire that proves to have faulty components or workmanship. At our option we may decide to repair, or replace, at no charge a fire that proves to have faulty components or workmanship.

Telephone Help Line. In the event of a problem with a fire the first course of action should be to telephone our technical department on 020 8254 6802 during normal working hours 9 - 5.30 Monday - Friday (closed 1 - 1.30). If possible this should be done before the installer leaves site as we may well be able to resolve the problem over the phone, and, in any event it will save the installer a return visit to site. If we are not able to resolve the problem over the phone we will decide the most expedient way of resolving the problem and this is likely to be to send replacement parts. It is possible that we will ask you to return the fire or parts of the fire and if this is the case we will log your details and give you a return reference number.

Returning the Fire and parts thereof. After assessment we might consider it best to return part of the appliance, such as the burner only, for testing. In this example the burner can then be thoroughly inspected and any signs of installation faults can be reported back to you. After any repair work is carried out the flow rates can be checked and re-set if necessary in order to fully comply with CE approval. **Note:** It is a condition of the warranty that you do not return any parts to us unless we request you to do so. For example if we request that the burner only is returned and you send the entire appliance, the fuel bed and other items could be damaged or lost during the return delivery to us. We will not be liable for any such breakages, or losses

Under no circumstances should any attempt be made to repair the burner on site without our express knowledge and approval during the warranty period.

This guarantee is given subject to the following provisions:

1. That the installation is carried out by a GAS SAFE registered installer (we may require their registration details).
2. That the appliance is installed and used in accordance with our Installation & User instructions.
3. That the gas supply pressure at the appliance is not more than 3mbar below the gas pressure stated on the data plate when the appliance is running on high flame, with any other major gas appliances also running.
4. That the fireplace and flue system conform to relevant local codes, building regulations and British Standards.
5. This Guarantee is not transferable and relates to the original installation only.
6. The appliance has not been subject to misuse or accident or been modified or repaired by any person other than the authorised employee or authorised representative of Nu-Flame Ltd.
7. The Record Data section on the front of the Installation & Servicing Instructions is to be completed on installation.
8. Nu-Flame Ltd accepts no liability for any consequential loss or damage arising from the use or failure of the product or any information provided, including, but not limited to, economic or financial loss, damage to peripheral equipment or products, loss of use, productivity or time.
9. That the serial no. data plate on the burner is intact.

This guarantee in no way reduces your statutory rights.

This guarantee supersedes any previously published guarantees.

Chargeable Repairs During And After The Warranty Period

If a repair is chargeable during the warranty period, due to installation faults we will inform you and where possible give you a quote, or if this is not possible, a price guide before starting work. We cannot always give a firm cost until we commence the repair as it is not always possible to tell which components have been damaged.