



# **THE VITESSE B.F.**

**BALANCED FLUE INSET CONVECTION HEATER SUITABLE  
FOR NATURAL GAS & PROPANE**

**USE, INSTALLATION & SERVICING INSTRUCTIONS**

**ALL INSTRUCTIONS MUST BE LEFT WITH THE USER FOR  
SAFE KEEPING**

**Important**

**A Carbon Monoxide Alarm Complying With BS EN 50201 Must Be Provided  
In The Room Where The Gas Fire Is Installed.**

**It Must Be Fitted And Maintained In Line With The Manufacturer's Instructions.**

**All Propane (LPG) Installations Should Be Fitted with a Over Pressure Shut Off Valve (OPSO).**

**The glass panel and outer parts of this fire will become hot during use, cloths or combustible items  
must not be placed close to or on the fire. We recommend that a Fireguard conforming to BS8423  
should be used for protection of Young Children the Elderly, Infirm and Pets.**

**MANUFACTURED by:**

**Nu-Flame Limited**

**Unit 4, Kimpton Trade & Business Centre**

**Minden Road, Sutton, Surrey SM3 9PF**

**Tel: 020 8254 6802**

**Fax: 020 8641 9992**

**Email: [sales@nu-flame.co.uk](mailto:sales@nu-flame.co.uk)**

**Country of Destination – GB & IE**

# CONTENTS

Section No	Subject	Page
<b>User Section</b>		
-	Contents Page	2
-	Box Contents	2
-	Fitting Kit Contents	3
-	Minimum Distances for Flue Terminal Positions	4
1	Important Notes	5
2	Lighting & Controlling the Fire	6
3	Cleaning the Fire	10
4	Servicing	10
<b>Installation Section</b>		
-	Record Data	10
5	Installation Requirements	11
6	Appliance Data	11
7a,b,c & d	Appliance Fire, Flue, Trim & Wall Fume Dimensions	12,13 & 14
8	Flue Requirements	14
9	Ventilation	14
10	Gas Supply	14

**Sections 11 & 12 are for the various installation applications for Traditionally Built Houses**  
**Section 13 covers the requirements for Timber Frame Houses**  
**Ensure you refer to the Section relevant to your requirement**

11	Fire Surround Application with a Purpose Built Fireplace Enclosure Fireplace Construction, Hole Position, Sizing & Cutting the Flue	15
12	Hole in the Wall Application - Using Slips Fireplace Construction, Hole Position, Sizing & Cutting the Flue	17
13	Timber Frame Installations (Fire Surround & Hole in the Wall)	19
14	Preparing Fire and Preparing the Flue	23
15	Fitting the Fire	24
16	Arrangement of the Fuel Effect	26
17	Fitting the Burner Heat Shield	27
18	Testing, Commissioning & Use	28
19	Briefing the Customer	28
20	Servicing	28
21	Fault Finding Guide, Symptoms & Possible Cause	29
22abc&d	Energy Class & Product Fiche	32
23a&b	UK & EU Declaration of Conformity	36
24	Diagram of Infrared Control System	38
-	Guarantee	39

### **BOX CONTENTS (The Fire comes in 4 - 6 boxes)**

Box 1 - Large box - contains the Fire, the Matrix Tray, chosen Control System and the Fitting Kit (see overleaf for fitting kit contents).

Box 2 - The Fuel Bed, (Coal or Pebbles and Matrix).

Box 3 - The Trim (Flat or Curved), with appropriate Burner Heat Shield.

Box 4 - The Standard Flue Assembly (or optional, if ordered, Long 850mm Flue Assembly), Foam Flue Cutting Aid, Flue Wall Plate & Flue Terminal Guard.

### **Depending on the options ordered there may be 1 or 2 further boxes:**

A Cast Fret (optional), if ordered, will be in its own box.

A Profile Trim (optional), if ordered, will be in its own box.

**IMPORTANT : THE VITESSE BF CAN ONLY BE USED WITH NU-FLAME'S CE APPROVED FRETS & FENDERS**

## **VITESSE B.F. FITTING KIT CONTENTS:**

- 1 # Cable Fixing Kit (comprising 2 # cables and fittings, 4 # eye screws, 4 # plastic plugs).
- 3 # No10 x 40mm Stainless Steel Round Head Screws to fix Flue Terminal Guard.
- 3 # Stainless Steel Washers to fix Flue Terminal Guard.
- 3 # No10 Rawlplugs to fix Flue Terminal Guard.
- 3 # M5 x 25mm Stainless Steel Washers to fix Flue Terminal Guard.
- 4 # No10 x 40mm Stainless Steel Round Head Screws to fix Flue Wall Plate.
- 1 # 700mm length 6mm x 4mm self adhesive Silicone Sealing Strip for fixing to Flue Wall Plate.
- 4 # No10 Rawlplugs to fix Flue Wall Plate.
- 4 # No6 by 10mm self tapping screws for securing the Flue to the Wall Plate.
- 3 # No6 by 10mm self tapping screws for securing the Flue to the Spigot of the Fire.
- 2 # No6 x 10mm self tapping screws for fixing Burner Heat Shield.
- 2 # No6 x 5mm blunt self tapping screws for fixing the stainless steel Top Louvre / Heat Shield. The Top Louvre / Heat Shield is only supplied with Flat Trims - it is not required if using a Curved Trim.
- 4 # Magnets for holding Front Trim in position (optional Profile Trim has 4 additional magnets which will be packed in with the Profile trim).
- 1 # 10mm Back Nut & olive to connect 8mm copper pipe gas supply to the burner (via the isolation elbow).
- 1 # 2,050mm length of 6mm x 4mm self adhesive silicone sealing strip for around the frame and base of the fire.
- 1 # length of Aluminium Tape for sealing the flue.
- 1 # 2.5mm Steel Cutting Drill for drilling the flue.
- 1 # No2 Pozidriv screwdriver (for burner heat shield and glass panel removal/fitting).
- 1 # Set of Instructions / Warranty.

*Note – No6 screws are a smaller diameter than No8 screws.*

## MINIMUM DISTANCES FOR FLUE TERMINAL POSITIONS

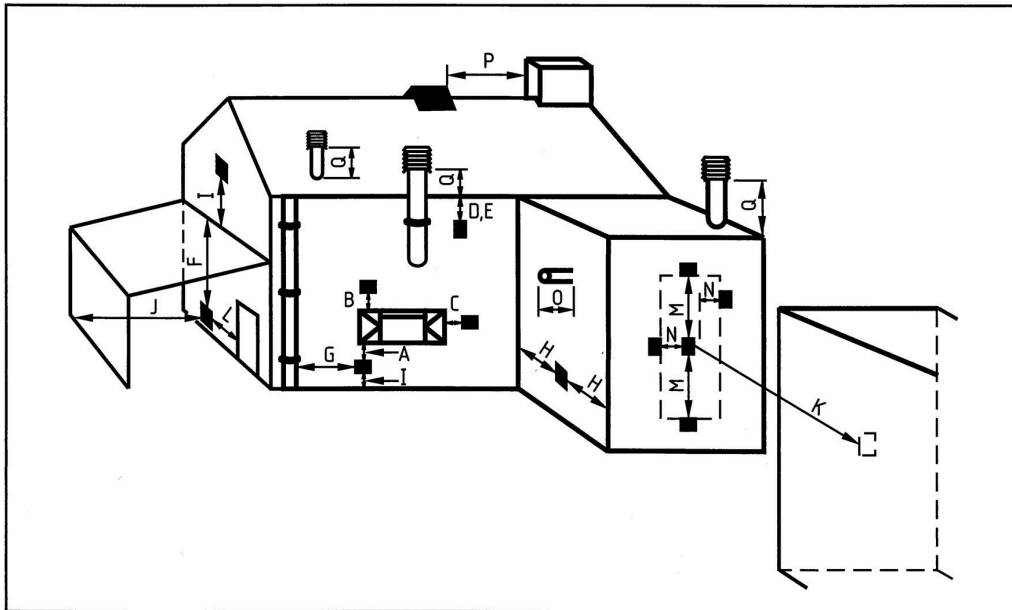

Symbol	Location	Minimum dimensions
A*	Directly below an opening, air brick, opening windows, etc.	300 mm
B*	Above an opening, air brick, opening window, etc.	300 mm
C*	Horizontally to an opening, air brick, opening windows, etc.	300 mm
D	Below temperature-sensitive building components, e.g. plastic gutters, soil pipes or drain pipes	300 mm
E	Below eaves	300 mm
F	Below balconies or car port roof	600 mm
G	From a vertical drain pipe or soil pipe	300 mm
H**	From an internal or external corner	600 mm
I	Above ground, roof or balcony level	300 mm
J	From a surface facing the terminal	600 mm
K	From a terminal facing the terminal	600 mm
L	From an opening in the car port (e.g. door, window) into the dwelling	1 200 mm
M	Vertically from a terminal on the same wall	1 500 mm
N	Horizontally from a terminal on the same wall	300 mm
O	From the wall on which the terminal is mounted	0
P	From a vertical structure on the roof	N/A
Q	Above intersection with roof	N/A

NOTE N/A = Not applicable.

\* In addition, for temperature and structural reasons, the terminal should be no nearer than 300mm to an opening in the building fabric formed for the purpose of accommodating a built in element such as a window frame.

\*\* The reference to external corners does not apply to building protrusions not exceeding 450mm, such as disused chimneys on external walls.

# THE VITESSE B.F. USER INSTRUCTIONS

## 1. - IMPORTANT NOTES

- a. This appliance must be installed by a properly qualified (in accordance with National & Local Regulations) Installation Engineer.
- b. The connection and installation of this appliance are to be according to the Rules in Force and National & Local Codes, and in accordance with these Instructions.
- c. This appliance does not require any purpose provided additional ventilation.
- d. Consult all Instructions before Installation and Use.
- e. Do not throw rubbish on, or attempt to burn any materials on this appliance. Any Debris or Foreign Matter must be removed from the fire.
- f. Under No Circumstances must this fire be used if the Glass Panel is broken, damaged, cracked or has been removed.
- g. The glass panel and outer parts of this fire will become hot during use, cloths or combustible items must not be placed close to or on the fire. We recommend that a Fireguard conforming to BS8423 should be used for protection of Young Children the Elderly, Infirm and Pets. Other than Control Knobs, Switches and Ash Pan Knob all surfaces are Classified as Working Surfaces.
- h. The Fire can only be sited on an Outside Wall and the Flue Terminal Position **MUST BE** in accordance with BS5440 : Part 1. See diagram and table on previous page, which shows Acceptable Flue Terminal Positions.
- i. The Flue Terminal or Guard on the Outside Wall **MUST NOT** be obstructed in any way or in the vicinity, for example by placement of Plants, Bushes, Fences or Leaning Objects.
- j. Do not use a hose pipe or garden sprinkler in the vicinity of the Flue Terminal on the Outside Wall.
- k. If any changes are to be made to the property after installation in the area of the Flue Terminal consult a properly qualified person/installer as this could affect the safe operation of the fire.
- l. The Terminal Guard supplied with the fire **MUST** be used if there is free access to the area at the Flue Terminal.
- m. The appliance should be Serviced Annually in accordance with the Gas Safety & Uses Regulations.
- n. The Fire is supplied with a specially designed flue system and no other flue system can be used.
- o. If at any time you smell gas or fumes turn the fire off and contact your Installer.
- p. These Instructions must be left with the User for future reference.
- q. During its first period of use any protective coatings and oils will burn out of the appliance and it is wise to ventilate the room for the first hour of use.
- r. This appliance is fitted with a special Pilot Assembly, which automatically shuts off the gas supply to the fire if the gas is shut off. It must not be tampered with and only replaced with a genuine Nu-Flame Pilot System.
- s. Advise the Customer that the fire is fitted with a Safety Pressure Relief System and if the fires ignition should ever become delayed, or noisy then the fire **MUST NOT** be used until checked by a Qualified Engineer/Installer.
- t. In the event that the fire shuts down for any reason, attempt to restart it. If there is a continuing problem, call in a properly qualified specialist engineer.
- u. There are no user replaceable parts in the appliance apart from the batteries, if a High Level or Thermatronic Electronic Control System was ordered.
- v. Coal or Pebble fuel effects, manufactured from refractory fibre, are supplied with this appliance. Do not use real coals or pebbles as this is dangerous. If the simulated fuel bed components need renewing please obtain suitable replacements from a Nu-Flame Stockist.
- w. No combustible materials e.g. curtains must be closer than 500mm to the fire.
- x. For Fire Surround Applications a 150mm (6") combustible shelf can be fitted above the fire provided it is 250mm above the Fireplace Opening.
- y. The Fire can be installed into a suitably designed fire surround with a 150°C Rating.
- z. Over time some wall staining will occur above the fire and this is due primarily to particles of dust present in the hot convection air circulating up and over the fire/surround and sticking to the wall.

**! IMPORTANT NOTES ! THE GLASS PANEL ON THIS FIRE WILL BECOME VERY HOT DURING OPERATION - SEE ITEM 'g.' ABOVE.**

**It is quite normal for the fire to make popping and burbling sounds when in use, as would a solid fuel fire.**

**It is quite normal for the push buttons on the High Level Button Controls to feel hot to touch.**

**The Fire Must Be Installed in a Ventilated Enclosure to prevent Overheating as detailed in the Installation Sections.**

### **Health & Safety Advice Refractory Ceramic Fibre (RCF) Advice when working with Fuel Bed Components including Installing, Servicing and Disposal.**

The Fuel Effect parts and possible Linings of this fire are made from Refractory Ceramic Fibre (R.C.F.) a Class 2 Carcinogen which is a material designed for this Application. Excessive exposure to these types of materials may cause temporary irritation to eyes, skin and respiratory tract. Therefore take care when handling these articles to ensure dust is kept to a minimum.

It is not necessary to wear protective clothing when handling these articles but we do recommend you follow the normal hygiene rules of not smoking, eating or drinking in the work area, and always wash your hands before eating or drinking.

To minimise the release of RCF fibres during installation and servicing a HEPA filtered vacuum is recommended to remove any dust accumulated in and around the fire both before and after working on it.

When Servicing and if replacing these parts we do not recommend they are broken up but are sealed within a heavy duty polythene Bag and labelled as "RCF waste". This is not classified as "hazardous waste" and may be disposed of at a local licensed landfill site.

## 2. - LIGHTING & CONTROLLING THE FIRE

### General

The fire is available with 5 Control Options: a Manual Control (Fire is lit and adjusted manually), a side Trim fitted 2 Button High Level Control (Fire when lit can be controlled with the Push Buttons), a side Trim fitted 3 Button High Level Control (Fire can be lit and controlled with the Push Buttons) or Thermatronic Radio Frequency Electronic Control System (Fire is lit & operated with a Handset) or the Thermostatic Thermatronic Radio Frequency Electronic Control System (Fire is lit & operated with an Handset which also can control the room temperature plus other features).

### 2.1 - LIGHTING & CONTROLLING THE FIRE - MANUAL CONTROL

**Remove the Ash Pan to get access to the Control Knob used to operate the Fire.**

**a. Switching On/ignition.** Depress the control knob & turn counter clockwise. Gas will flow to the Pilot Burner (Pilot Burner is visible looking down through the glass at the left side), the Piezo Igniter will give off first one, then, as you turn, a second high voltage spark & the Pilot Burner will Light. (More than one attempt may have to be made on first lighting.)

Keep the Control Knob depressed for approximately 10 seconds to heat up the Thermocouple.

Turn the Control Knob fully counter clockwise to release gas to the Main Burner.

**b. Control of Gas Flow.** Turning the Control Knob clockwise reduces the gas flow from Maximum to the Pre-Set Minimum Setting.

Turning between Maximum & Minimum does not actuate the Piezo Igniter. The Control Valve can only be set on the Pilot by depressing the control knob & turning it to the pre-selected pilot position.

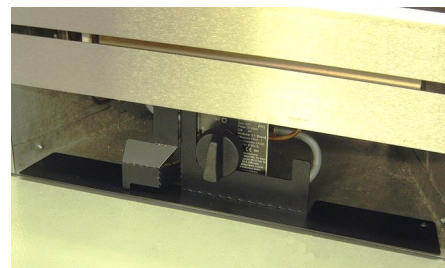
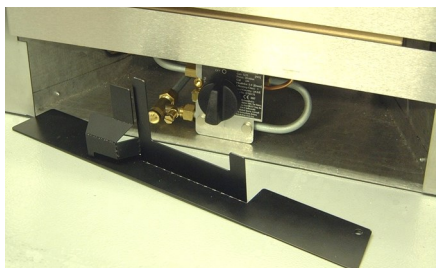

**c. Switching Off.** Press the Control Knob in at the Pilot Position & turn Clockwise to Off.

Note - For manually controlled fires a black cover plate is supplied to cover some of the pipe work and associated fittings under the burner tray. This is freestanding and is for cosmetic purposes only; it need not be used If preferred. The controls can be operated with the cover in place (see photos on previous page).

### 2.2 - LIGHTING & CONTROLLING THE FIRE - 2 BUTTON HIGH LEVEL CONTROL

**Note: It is quite normal for the push buttons on the High Level Button Controls to feel hot to touch.**

#### Requires Pilot Ignition First.

The side trim positioned High Level Control System is a battery operated gas fire control system that uses push buttons linked to a main control at the base of the fire. This control system is used with an oxy-pilot and has all the safety features required by law and CE approval.

Once the fire is lit by operating the Control behind the Ash Pan Cover the settings can be controlled by the 2 Push Buttons on the upper right side of the Trim.

#### Using the System

**Remove the Ash Pan Cover to get access to the Control Knob used to operate the Fire.**

**a. Switching On/ignition.** Depress the right control knob & turn counter clockwise. Gas will flow to the Pilot Burner (Pilot Burner is visible looking through the fender, under the flue bed, at the front right hand corner), the integral Piezo Igniter will also give off a high voltage spark & the Pilot Burner will Light. (More than one attempt may have to be made on first lighting.)

Keep the Control Knob depressed for approximately 10 seconds to heat up the Thermocouple.

Turn the Control Knob fully counter clockwise to release gas to the Main Burner.

**b. Control of Gas Flow Using the Side Trim Push Buttons.** Press the lowest button to gradually reduce the gas flow from Maximum to the Pre-Set Minimum Setting, you will hear the motor turning the control. Keeping the Lower Button depressed will eventually turn the main burner off leaving the pilot alight.

To relight the main burner or increase the heat setting from low, press the Upper Button to achieve settings between low and high. When the fire has reached high the control under the fire will click repeatedly, release the button.

**c. Switching Off.** Remove the Ash Pan Cover and turn the right Control Knob Clockwise to Off.

**d. Battery Replacement .** The Batteries should be replaced every season, you will notice they need changing as gradually the Push Buttons cease to operate the Control.

**e. Changing the Batteries.** Remove the Ash Pan Cover and you will find the Battery Box on the right hand side.

Pull towards the front taking care not to strain the connecting wire. Using a small screw driver remove the screw, slide off the cover and take out the Batteries. Replace with 4 x AA good quality alkaline batteries, operate the Push Buttons to check the Batteries are fitted correctly.

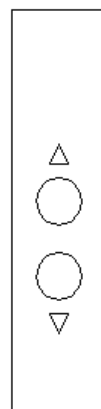

**Note: Only Change The Batteries When The Fire Is Cold**

### 2.3 - LIGHTING & CONTROLLING THE FIRE - 3 BUTTON HIGH LEVEL CONTROL

**Note: It is quite normal for the push buttons on the High Level Button Controls to feel hot to touch.**

#### The 3 Button High Level Control Lights the Pilot and Controls the Fire.

The side trim positioned High Level Control System is a battery operated gas fire control system that uses push buttons linked to a main control at the base of the fire. This control system is used with an oxypilot and has all the safety features required by law and CE approval.

**Note: The Centre Button is both the Ignition and Off Button.**

#### Using the System

- Ignition.** Simultaneously press and hold the Centre Button until a short acoustic signal confirms that the sequence has begun, then release the buttons. Continuous audible signals confirm that ignition is in progress. When pilot ignition is confirmed the motor will open the valve to maximum flame height – this takes about 30 seconds. When the fire is first operated and on occasions when the fire has not been used for some time the Pilot may not light after pressing the Centre Ignition Button even though the acoustic sound may have been heard. On these occasions it may be necessary to repeat the sequence a number of times to light the pilot. This is quite normal.
- Flame Height Adjustment.** Press the bottom down arrow button until the flame height is at the desired position. If you try to go beyond the preset low flame minimum height the fire will turn off leaving the pilot burner alight (This is the standby position). You will learn from experience the minimum preset flame height.
- Relighting the Fire.** To relight the fire from the standby position, or to increase the flame height from low flame, press the top up arrow.  
Please note that you can have the flame height anywhere between maximum and preset low.  
For fine adjustment simply tap the up or down arrows.
- Switching Off.** Press the centre button.
- Battery Replacement.** The Batteries should be replaced every season, you will notice they need changing as gradually the Push Buttons cease to operate the Control.
- Changing the Receiver Batteries.** To change the Receiver Batteries remove the Ash Pan Cover and locate the electronic receiver box, underneath the fire on the right hand side. Pull towards the front taking care not to strain the connecting wire. Slide open the plastic cover to gain access to the battery compartment. Replace with 4 x AA good quality alkaline batteries, operate the Push Buttons to check the Batteries are fitted correctly. Remember to put it back in the same position.



**Note: Only Change The Batteries When The Fire Is Cold**

### 2.4 - LIGHTING & CONTROLLING THE FIRE – THERMATRONIC HAND HELD RADIO FREQUENCY REMOTE CONTROL

The Thermatron & Thermotronic Thermostatic Control Systems are both battery operated gas fire remote control systems that use a microprocessor to provide the working sequences needed by the fire, and when used with an oxypilot have all the safety features required by law and CE approval.

Commands are accepted by the microprocessor when buttons are pressed. An audible beep means that the command has been received, and the push button should immediately be released to allow the control to operate.

#### Using the Thermotronic Remote Control System

Control can only be achieved if the Handset is pointed at the Fire. The red light will flash each time you press a button on the Handset.

- Ignition.** Simultaneously press and hold the red button and the right upper button (linked by line) until a short acoustic signal confirms that the sequence has begun, then release the buttons. Continuous audible signals confirm that ignition is in progress. When pilot ignition is confirmed the motor will open the valve to maximum flame height – this takes about 30 seconds.

*It is normal for condensation to appear on the glass on start-up. This will clear after a minute or so.*

- Flame Height Adjustment.** Press the small flame button until the flame height is at the desired position. If you try to go beyond the preset low flame minimum height the fire will turn off leaving the pilot burner alight (this is the standby position). You will learn from experience the minimum preset flame height.
- Relighting the Fire.** To relight the fire from the standby position, or to increase the flame height from low flame, simultaneously press and hold the large flame button until the desired flame height is achieved.  
Please note that you can have the flame height anywhere between maximum and preset low.  
For fine adjustment simply tap the small or large flame buttons.
- Switching Off.** Press the red/off button on the handset.



### 2.5 - LIGHTING & CONTROLLING THE THERMATRONIC THERMOSTATIC RF SYSTEM

Control can only be achieved if the Handset is pointed at the Fire.

You will see that the Handset as a screen with symbols and reference should be made to the following screen settings shown for each stage of operation. With the fire in the off position the screen will look as shown below.

This is the Manual Setting display and will be used to first light the fire.

The screen with symbols are shown below.

**Note: Radio Frequency Symbol Shows Only When Pressing Handset**

Room Temperature

Handset in Manual

Battery Charge Level

Time of Day



On the next page you will see the photograph of the handset shown again with details of how to operate the Handset.

## 2.6 Using the Thermostatic Thermatronic RF System

Control can only be achieved if the Handset is pointed at the Fire.

**a. Ignition.** Simultaneously press the Off and Large Flame Buttons (linked by the line/star symbols) until a short acoustic signal confirms that the sequence has begun, then release the buttons.

Continuous audible signals confirm that ignition is in progress.

When pilot ignition is confirmed the motor will open the valve to maximum flame height – this takes about 30 seconds. The main burner will then light at the high flame setting.

**b. Flame Height Adjustment.** Press the small flame button until the flame height is at the desired position. For fine adjustment tap the Large Flame or Small Flame buttons.

If you try to go beyond the low flame setting the fire will turn off the main burner leaving the pilot burner alight (This is the standby position).

You will learn from experience how to achieve the minimum low flame setting.

**c. Relighting the Fire.** To relight the fire from the standby position, or to increase the flame setting from low flame, simply press the large flame button.

Please note that you can have the flame height anywhere between maximum and low.

For fine adjustment simply tap the large and small flame buttons.



**Note:** You can also automatically set the fire at either Tall or Low Flame setting by pressing the desired flame Button twice.

**d. Switching Off.** Press the off button

You can now proceed to the other features of the Handset such as Setting the Time, Temperature and Time Programmes.

**e. Setting Temperature - Time in Centigrade-24Hour Clock or Fahrenheit-12Hour Clock.**

- Simultaneously Press the Off and the Down Arrow buttons until the display changes from Fahrenheit -12Hour Clock to Celsius -24Hour Clock and visa versa.

**f. Setting the Time.**

The time of day will flash after either:

- Installing the batteries or
- By Pressing the Large Flame and Small Flame buttons at the same time.
- Press the Large Flame button to set the Hour.
- Press the Small Flame button to set the Minute.
- Press Off or simply wait to return to the manual screen.

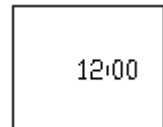

**IMPORTANT :** For the following modes of controlling the fire automatically for Temperature or Timer Programs the Fire Must be left in the Standby Setting (Pilot Lit) and left on the chosen Setting, with the Screen showing either Temp or Timer.

**g. Setting the Day Time Temperature.**

- Briefly Press the Set Button to scroll to TEMP (Sun \* Symbol - Daytime) Mode.
- Hold the Set Button until the TEMP flashes then release.
- Now press the Large Flame button to increase the Daytime - Sun temperature. or
- Press the Small Flame button to decrease the Sun-Daytime temperature.
- You can now press the Set Button to scroll to setting the Night Time Temperature or press off to return to Manual Screen.



**h. Setting the Night Time Temperature.**

- Briefly Press the Set Button to scroll to TEMP (Moon Symbol ∩ Night Daytime) Mode.
- Hold the Set Button until the TEMP flashes then release.
- Now press the Large Flame button to increase the Night ∩ Time - Moon temperature. or
- Press the Small Flame button to decrease the Night Time ∩ Moon temperature.
- You can now either leave the handset on the TEMP setting and with the fire lit the room temperature will be controlled or return to the Manual Screen. Your Settings will remained stored.



**Note:** With the Temperature Settings now set the Handset will have to be left in the TEMP mode to control the fires temperature.

**Note:** In the Manual Mode neither of the Automatic TEMP or TIMER settings will be active.

**Note:** If you Set the Room Temperature below the present room temperature the fire will go straight to the Standby Setting until the temperature drops below the Set Temperature at which point the main burner will relight.

**Note:** The Room Temperature is sensed by the Handset so place it in the ideal position to control the room temperature.

**Note:** An Holder is available for the Handset as an optional extra and this should be positioned to control the set room temperature.

**Note:** If at any time you wish to correct or check the settings you have made you can simply keep pressing the Set Button until the screen displays the Manual Setting and repeat the operations as detailed above.



## i. Setting the Timer Programs P1 and P2 for Daytime & Night Time Settings.

- The Timer Programs are identified by the symbols P1 and P2 on the screen and each can be set for both daytime (sun symbol) and night time (moon symbol) settings.

**Note :** Both Programs have to be set, you cannot just set one program, however you can set both at the same settings.

### Setting the P1 (Program 1), On Time

- Briefly Press the Set Button to scroll to TIMER Mode.
- Hold the Set Button until P1 Sun Symbol (Daytime) is displayed and the time flashes.
- Press the Large Flame button to set the Hour.
- Press the Small Flame button to set the Minute.



### Setting the P1 (Program 2), Off Time

- Briefly press the Set Button to scroll to the P1 Moon Symbol (Night time) is displayed and the time flashes.
- Press the Large Flame button to set the Hour.
- Press the Small Flame button to set the Minute.



### Setting the P2 (Program2), On Time

- The Screen will automatically proceed to setting the P2 Settings
- Briefly Press the Set Button to scroll to the P2 Sun Symbol (Daytime) is displayed and the time flashes.
- Press the Large Flame button to set the Hour.
- Press the Small Flame button to set the Minute.



### Setting the P2 (Program2), Off Time

- Briefly press the Set Button to scroll to the P2 Moon Symbol (Night time) is displayed and the time flashes.
- Press the Large Flame button to set the Hour.
- Press the Small Flame button to set the Minute.
- Both Programs** Press Off or simply wait to return to the Manual Screen.



**Note :** With the Programs now set the Handset will have to be left in the TIMER mode to enable the programs to control the fire.

## 2.7 - GENERAL - ALL THERMATRONIC CONTROLS

- Battery replacement is recommended at the beginning of each heating season, or when an acoustic error message sounds at ignition.
- Error Message – Long signals (0.8 second tone – 0.2 second break) during ignition – probable cause batteries in electronic receiver box are nearly discharged.
- Error Message – 5 second continuous tone – probable cause – cable disconnected or on/off switch on valve is in off position.
- Batteries - Electronic Receiver Box - 4 x AA good quality alkaline - Handset - 1 x PP3 good quality alkaline.
- To change the Handset battery slide open the plastic panel on the back of the Handset.
- To change the Receiver Batteries remove the Ash Pan Cover and locate the electronic receiver box, underneath the fire on the right hand side. Pull towards the front taking care not to strain the connecting wire. Slide open the plastic cover to gain access to the batteries. Remember to put it back in the same position under the metal shield.

**Note: Only Change The Batteries When The Fire Is Cold**

## 2.8 - RESETTING THE MERTIK MAXITROL LOGIC CIRCUITS - IF THE HANDSET DOES NOT WORK ONLY APPLIES TO THE THERMATRONIC HAND HELD RADIO FREQUENCY CONTROLS

**Basic Reset** - It sometimes happens that (such as when the handset buttons are pressed out of sequence) the fire stops working because the logic circuits get confused and need to be reset.

To do this, simply remove the 4 x AA batteries from the Receiver Box (see section 2.5f above), wait for 1 minute and then refit the batteries. Wait for another minute and then point the handset at the fire and press the red/off button. Wait for another minute and then start the fire as normal. If the fire does not start repeat the resetting procedure. If the fire still does not work a Full Reset can be tried (see next page).

**Full Reset** - If you obtain a new handset the control system will need to learn the handset's unique code via a Full Reset. Also, if the fire is not working and the Basic Reset (described on page 7) has not worked a Full Reset can be carried out:

Remove the Ash Pan Cover and locate the electronic Receiver Box.

Locate the Reset Hole on the side of the Receiver and using a pen press and hold in the Reset button until you hear two beeps.

The first beep is short and the second beep is long. After the second beep release the Reset Button.

Now on the Handset, within the next 20 seconds press and hold the Small Flame Button until you hear two additional short beeps confirming the code is set in the Receiver.

If you hear one long beep the Code as not been set so repeat the procedure.

If after carrying out the above procedure the situation is not corrected it will be necessary to contact your Installer.

**Note: For the Installation/Service Engineer** - Resetting of the Handset & Control System is also covered in Section 21.1 page 25.

### 3. - CLEANING THE FIRE

**Note: Marks on the Glass Panel are Not Covered by the Manufactures Warranty.**

- a. **Important** : Always Allow the fire to cool before carrying out any cleaning.
- b. **Please Note**: The glass panel surface within the room will be marked by air borne particles as air circulates through the fire from the room, this is quite normal and cannot be prevented.  
So the glass surface within the room can be cleaned with proprietary glass cleaners and any residue removed and dried afterwards.  
**No Abrasive Cleaners Must be used.**
- c. Within the fire it is quite normal for soot and stains to build-up on the inside of the glass panel, this is why we advise that the glass panel must be fully cleaned during the Annual Service, however you can remove the glass panel for cleaning as follows:
  - i. Remove the Ash Pan. Remove the Outer Frame Assembly, it is held in place with magnets quite tightly, Pull to Remove.
  - ii. Using the Screw Driver provided remove the 5 Special Countersunk Screws then Ease the Glass/Frame Assembly outward slightly at the base then Pull down and remove.
  - iii. To clean the glass panel use proprietary glass cleaners, however for stubborn stains use 'T Cut Original' and following treatment remove all residue and polish with a dry cloth.

Note: The glass is etched with the Nu-Flame logo ensure it is at the bottom right hand corner when refitting the glass panel.
- d. The outer surfaces of the fire can be cleaned with a damp cloth, do **not** use any abrasive cleaners.  
For Stainless Steel finishes we recommend a small amount of Baby Oil.

**! TIP !** Being Magnetic The 4 Trim Magnets, (8 Profile Trim), Can Be Easily Misplaced, Locate Them Immediately.

**! IMPORTANT NOTE !** The Fire **MUST NEVER** be used without the Glass Panel in place or if the Glass Panel is in any way damaged.

### 4. - SERVICING

- a. The fire should be Serviced Annually in accordance with the Gas Safety & Uses Regulations.
- b. This fire contains no User Serviceable Parts apart from batteries (only used with the Thermatronic Control System option).
- c. Servicing must be carried out by a Registered Installer.
- d. For Servicing or Spare Parts contact your Installer quoting the Fire Name, Model and Serial Number, which can be found on the Data Badge. To find the Data Badge/Plate; with the fire cool remove the Ash Pan, the Data Badge can be found at the base next to the Control Knob.
- e. In the event that the fire shuts down due to any reason, attempt to restart it. If there is a continuing problem, call in a properly qualified specialist engineer.
- f. **Under No Circumstances** must this fire be used without the Glass Panel or if it is broken damaged or cracked.
- g. The Matrix in the fire is a Moulded Ceramic Fibre component incorporating Silicone Binders and you may notice that it develops cracks during operation. This is natural shrinkage caused by exposure to high temperatures and is quite normal for the material and will in no way affect the operation of the fire.
- h. The fire is fitted with a Safety Pressure Relief System and if the fires ignition should ever become delayed, or noisy then the fire **MUST NOT** be used until checked by a Qualified Engineer/Installer.
- i. If at any time fumes are found to be emitting from the fire immediately turn the fire off.

Do not use and contact a Qualified Engineer/Installer.

## THE VITESSE B.F. INSTALLATION & SERVICING INSTRUCTIONS

### RECORD DATA TO BE COMPLETED & KEPT BY USER:

**IMPORTANT : THE VITESSE BF CAN ONLY BE USED WITH Nu-Flame's CE APPROVED FRETS & FENDERS**

PLACE OF PURCHASE ..... DATE .....

ADDRESS & TEL. NO. ....

APPLIANCE SERIAL NO. ....

INSTALLED BY ..... GAS SAFE REG. NO. ....

## 5. - INSTALLATION REQUIREMENTS

**THIS APPLIANCE MUST BE INSTALLED AND SERVICED BY A PROPERLY QUALIFIED, (IN ACCORDANCE WITH LOCAL & NATIONAL CODES), INSTALLATION ENGINEER.**

It is the Law in the UK that All gas appliances are installed by a competent person in accordance with the GAS SAFETY (INSTALLATION AND USE) REGULATIONS 1998 (As amended), the relevant British Standards for Installation work, Building Regulations, Codes of Practice and these Instructions. In the UK a Registered Installer is deemed competent. In the Republic of Ireland, all Irish Standards, Local Codes and Bord Gais recommendations should be adhered to.

The Installation should also be carried out in accordance with the following where relevant:

1. BS5871 Part 2
2. BS5440 Parts 1 & 2
3. BS6461 Parts 1 & 2
4. BS6891
5. BS8303

Building Regulations and Standards issued as relevant by the Department of the Environment or the Scottish Development Department. In addition, for installation in Timber Frame Houses, reference must be made to British Publications DM2 & DM3 'Guide for Installation in Timber Frame Housing' and the Institute of Gas Engineers Document 1GE/UP/7.

In the Republic of Ireland Installation should be carried out in accordance with IS813, ICP3, IS327, Building Regulations, Codes of Practice, these Manufacturers Instructions and any Rules In Force.

Particular Reference should be made to the Ventilation Requirements, for the UK this Appliance would not normally require any additional purpose provided ventilation, for the Republic of Ireland ventilation should be in accordance with IS813 Domestic Gas Installations.

Failure to comply with the above could leave the Installer Liable to Prosecution and Invalidate the Warranty.

### IMPORTANT

BEFORE PROCEEDING WITH THE INSTALLATION READ THESE INSTRUCTIONS CAREFULLY. THESE INSTRUCTIONS SHOULD BE LEFT WITH THE USER FOR SAFE KEEPING AND FUTURE SERVICING. PRIOR TO INSTALLATION ENSURE THAT THE GAS TYPE AND PRESSURE ARE AS STATED ON THE APPLIANCE DATA BADGE.

## 6. - APPLIANCE DATA

- a. Gas Type: See Data Plate, (Natural Gas at 20mbar or Propane at 37mbar).
- b. Burner Pressure: Natural Gas 18.6mbar cold Propane 36.2mbar cold
- c. Control System: Manual, High Level (Push Button) or Thermatronic (Fully Sequential) Control System operated by Handset pointed at Receiver.
- d. Fire Safety: Flame Failure Device & Pressure Relief System.
- e. Ignition: Manual-Integral Piezo Igniter, Thermatronic-Full Sequential Control.
- f. Inlet Connection: 8mm Compression Fitting to Gas Isolation Elbow.
- g. Category: I2H, I3P.
- h. Injector: Natural Gas (G20)-360 Single hole. Propane (G31) - 160 Single hole.
- i. Heat Input: High: Natural Gas (G20) - 5.4kW Gross (4.87kW Net). Propane (G31) - 5.2kW Gross (4.78kW Net).
- j. Heat Input: Low: Natural Gas (G20) - 2.0kW Gross (1.8kW Net). Propane (G31) - 2.0kW Gross (1.84kW Net).
- k. Efficiency Class: 1. The Efficiency of this appliance has been measured as specified in BS EN 613 and the results obtained were 81.1% Gross (90% Net) on Natural Gas and 82.2% Gross (89.4% Net) on Propane. The test data has been certified by BSI (0086) and can be used in the UK Government's Standard Assessment Procedure (SAP) for Energy Rating of Dwellings.
- l. Heat Output: High: Natural Gas (G20) - 4.4W Propane (G31) - 4.3kW
- m. Heat Output: Low: Natural Gas (G20) - 1.35kW Propane (G31) - 1.35kW
- n. Pilot Type: Natural Gas (G20) - G27.2. Propane (G31) - G24.1.
- o. Nitrous Oxide (NOx) - 130 mg/kWh

## 7a. - APPLIANCE DIMENSIONS

### FIRE SIZES

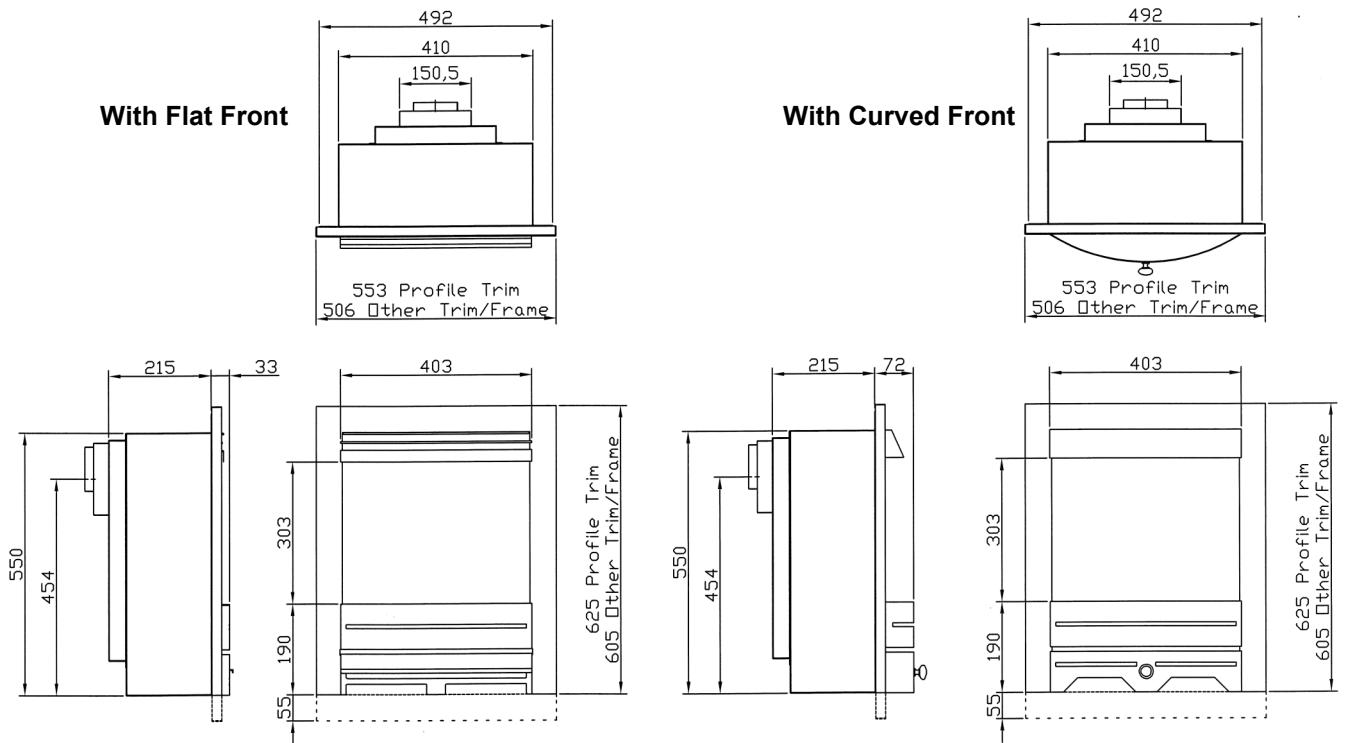

Solid lines denote 3 sided frame for fireplace use. Additional detail for "Hole in the Wall" frames is shown by dotted lines. Designs may vary; the diagram above is to show important dimensions only.

## 7b. - TRIM & WALL FRAME DIMENSIONS (Standen Trim & Vitesse Wall Frame Sizes)

**The Standen Trim** Supplied with fixing brackets and screws.  
(Minimum Flat = 612(w) by 630 (h))

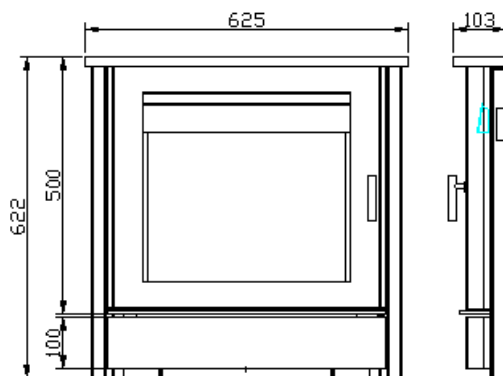

**Vitesse CF Outer Wall Frame**  
(Minimum Flat = 690(w) by 840 (h))

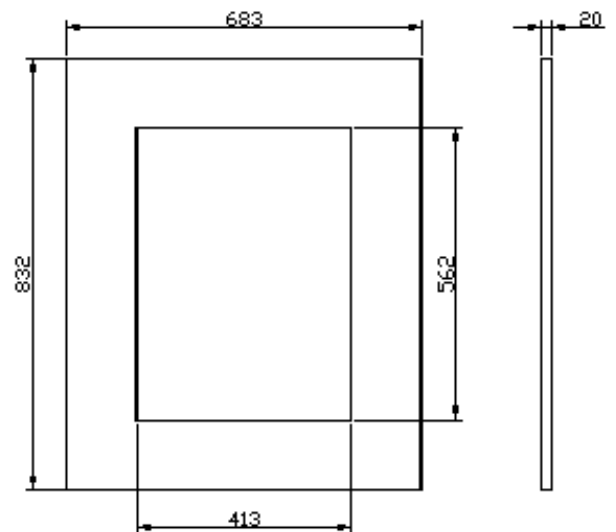

## 7c. - TRIM & FRAME DIMENSIONS (Other Optional Trim & Frame Styles)

Note: The following Trim & Frames are supplied separately with their own Instructions and fixings screws/brackets as required.

### The Arc Trim

The Arc Trim is supplied with fixing brackets.

The Arc Trim (Fireplace Version) can be installed with or without the Fireplace Arc Wall Frame.

The Arc Trim (Hole in Wall Version) is for Wall Mounted fire applications and can be used with or without the Hole in the Wall - Arc Wall Frame.

Also See Flat Area Requirements For Each Trim and Wall Frame Type

**Arc Wall Frame (Hole in Wall Version Frame)**  
Minimum Flat Area = 695mm(h) by 740mm(w)

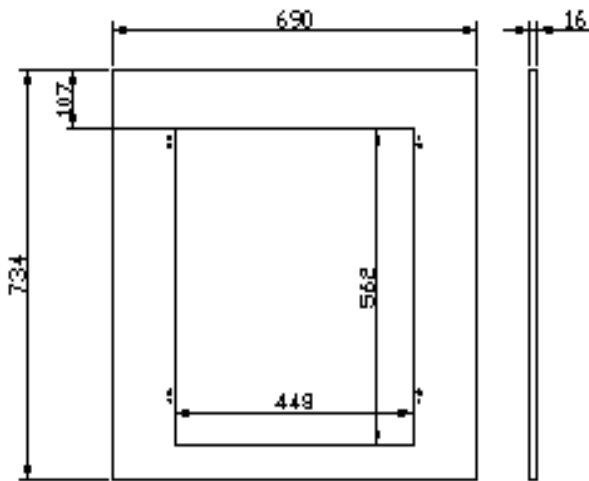

**Arc Wall Frame (Fireplace Arc Wall Frame)**  
Minimum Flat Area = 695mm(h) by 675mm(w)

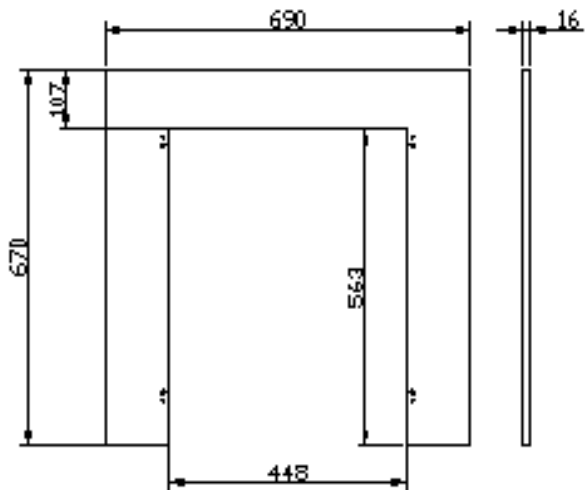

**Arc Trim** for use with or without the Arc Wall Frame (Hole in Wall Version) above.  
Minimum Flat Area = 545mm(w) by 615mm(h)

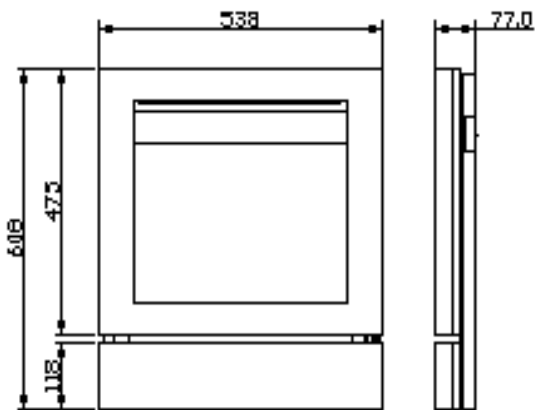

**Arc Trim** for use with or without the Arc Wall Frame (Fireplace Version) above.  
Minimum Flat Area = 545mm(w) by 615mm(h)

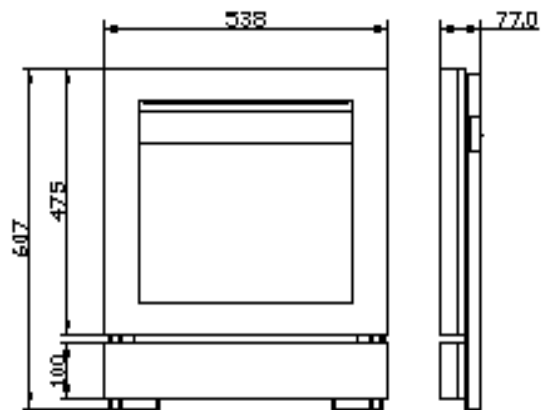

### IMPORTANT HEARTH REQUIREMENTS

#### ARC & STANDEN TRIMS

For Arc & Standen Trims The Hearth Must Not Have An Upstand Higher Than 15mm

## 7d. - APPLIANCE DIMENSIONS

### FLUE AND WALL SIZES

The Vitesse BF can be Installed with different sized Wall Frames and when calculating the flue length required before cutting the Flue Assembly you will need to allow for the thickness of the Wall Frame. The diagrams below show the maximum and minimum flue length options With and Without a Wall Frame fitted.

**See Sections 7b & 7c For The Different Frame Details**

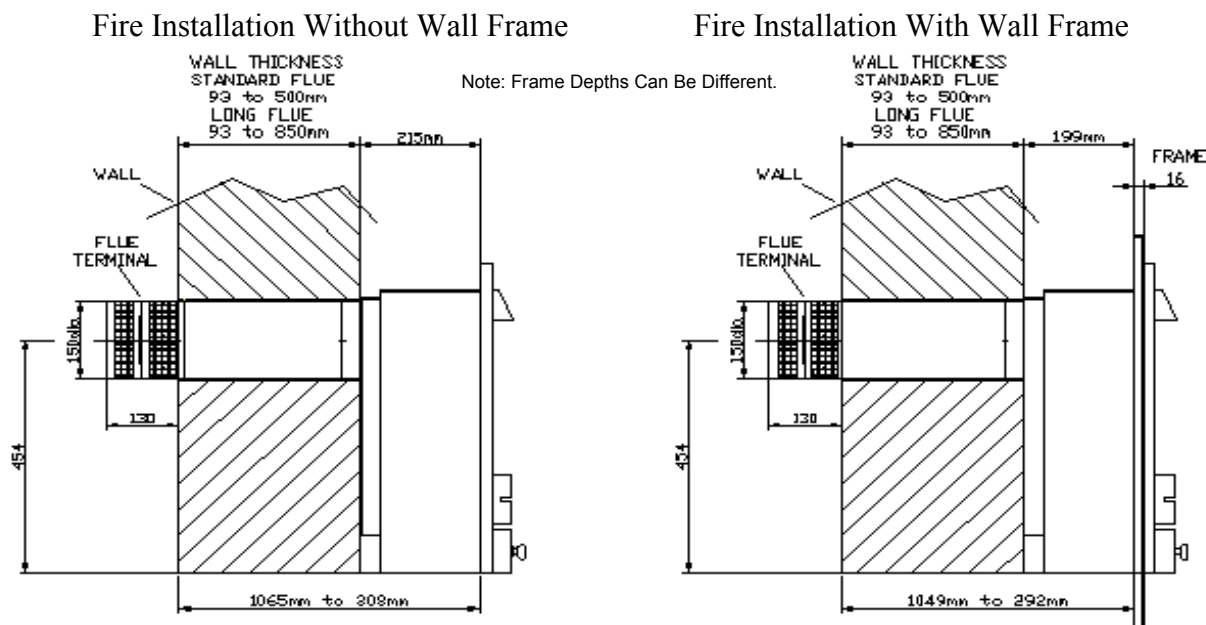

## 8. - FLUE REQUIREMENTS

- The Fire is supplied with a specially designed flue system and no other flue system can be used.
- The Fire and Flue Terminal System must be sited in accordance with BS5440 : Part 1. See Diagram and table on Page 4, which shows Acceptable Flue Terminal Positions.
- The Terminal Guard supplied with the fire **MUST** be used if there is free access to the area of the Flue Terminal.
- The Flue Terminal will become VERY HOT when the fire is in operation.
- The Standard Flue caters for Wall up to a maximum of 500mm thick and a minimum of 100mm thick.  
**Note : A Long Flue is Available that will cater for Walls up to 850mm thick and a minimum of 100mm thick**
- In the majority of Installations Building Work will be required, be it Masonry or Stud Work. For traditional buildings sections 11 & 12 shows the various options, one which **must** be decided before proceeding. However, in the case of Timber Frame Houses please refer to section 13.

## 9. - VENTILATION

- No additional purpose provided ventilation is required for this fire.
- This Appliance is fitted with a Flame Failure Safety Pilot System, which automatically shuts off the gas supply if the flame goes out for any reason. It **MUST NOT** be tampered with and only replaced with a genuine Nu-Flame Pilot Assembly.

## 10. - GAS SUPPLY

**It Is Recommended to Check The Next Section as Building Work May Affect the Gas Supply Routing.**

**With Timber Frame Houses Consult your Designer or Architect and refer to Section 13.**

- Carry out a gas soundness test before working on the gas supply.
- Gas supply provision should be made in accordance with the latest Gas Safety (Installation and Use) Regulations as amended.
- Confirm that the fire has been supplied for the correct gas to be used by checking the Data Badge in the base of the fire.
- A route for a concealed gas supply is provided through a hole in the rear of the fire, at a position of 65mm to the left of the centre of the fire and 39mm up from the base of the Fireplace/Builders opening. An isolation elbow is provided at the control inlet. Your 8mm gas supply pipe needs to protrude through the back of the convector box by approximately 145mm to achieve a neat connection onto the back of the isolator elbow on the burner.  
(This applies to both Manually Controlled and Thermatronic Controlled burners.)  
**IMPORTANT : ENSURE THE GAS SUPPLY PIPE IS ROUTED UNDER THE PIPEWORK OF THE BURNER ASSEMBLY SPECIFICALLY WITH THE THERMATRONIC CONTROL AS THE BURNER ASSEMBLY AS TO BE REMOVED DURING INSTALLATION AND FOR SERVICING.**
- Where the gas supply passes through walls, floors, voids, concrete and wall cavities the supply should be sleeved.
- Determine the gas supply pipe size required taking into account any other gas appliances.
- Determine where the gas supply pipe needs to terminate and fit the 8mm compression isolation/pressure test elbow provided.
- In common with all other gas appliances, dirt and debris in the gas system can block the valve and gas injectors on this appliance, and faults caused by this are not covered by the guarantee.  
Therefore it is important that all gas pipes **MUST** be purged of both air and debris.
- If you suspect that there may still be dirt and/or debris in the gas system, fit a filter in the pipeline, before the gas isolation/pressure test elbow.
- Do **not** use jointing compound on any compression fittings on the fire. The use of jointing compound on the compression joints on this appliance will possibly invalidate the guarantee, as it can get into the control mechanism and cause a malfunction.
- Seal off the isolation/pressure test elbow and check all gas connections for gas soundness before proceeding to fit the fire.

**! IMPORTANT NOTE !** Always reseal the pressure test point & check that it is gas tight - this accounts for a lot of recalls.

**Sections 11 & 12 are for the various Installation Applications for Traditionally Built Houses - Only one will apply.**

**For Timber Frame Houses refer to Section 13**

**! IMPORTANT NOTE ! The chosen installation should have been predetermined and arranged before installing the fire.**

**Ensure you refer to the Section relevant to your requirement.**

The Installation Applications Options Are:

11.0 Installation into a 150°C rated Fire Surround fitted with a Purpose Built Fireplace Opening.

12.0 Installation into a Hole in the Wall Application.

13.0 Installation into Timber Frame Housing.

**11. - FIRE SURROUND APPLICATION WITH A PURPOSE BUILT FIREPLACE OPENING**

**FIREPLACE CONSTRUCTION, HOLE POSITION, SIZING & CUTTING THE FLUE.**

**11.1 - FIRE SURROUND APPLICATIONS**

In this Application as a fire surround is being used we supply a Cable Fixing System as Drill Fixing may result in cracking of the back panel, which may not show until the fire has got hot and then cooled down over a number of operations.

Nu-Flame does not recommend the use of a 1 piece back panel as cracking can occur.

Nu-Flame will not accept responsibility for Cracked Back Panels due to Drill Fixing.

**MASONRY FIREPLACE ENCLOSURE SIZES FOR FIRE SURROUND APPLICATIONS**

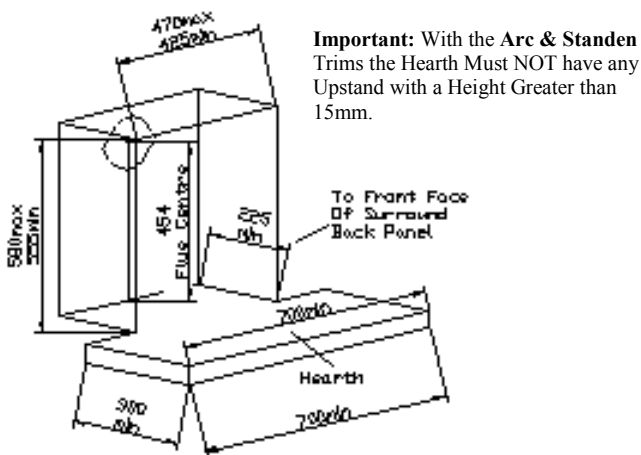

**FIREPLACE ENCLOSURE FOR FIRE IN COMBUSTIBLE FIRE SURROUND APPLICATIONS WITH STUDWORK**

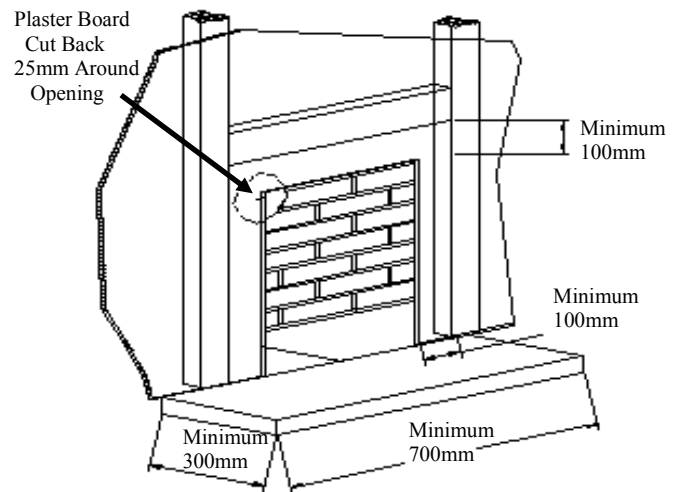

**Fireplace Construction & Shelf Details**

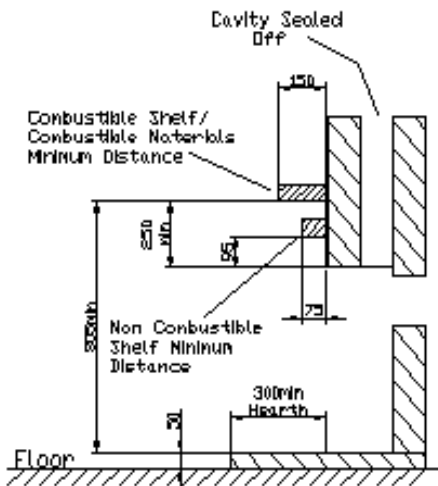

**Fireplace Lintel Position Details For Arc & Standen Trims The Hearth Must Not Have An Upstand Higher Than 15mm**

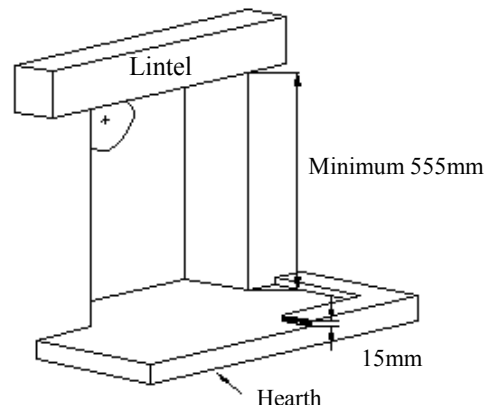

**NOTE: The minimum depth of 225mm allows 10mm for Cable Fixing System.**

**There must be no combustible materials inside the fireplace opening.**

## 11.2 - FIRE SURROUND REQUIREMENTS (See diagram in Section 11.1)

- a. If the Fire is to be fitted into a purpose made Fire Surround it must have a temperature rating of 150°C.  
Also due to the possibility of cracking we recommend that the Back Panel of the Surround is made of 3 pieces, top and sides. Some back panel materials, (Conglomerate), claiming a 150C rating may still not withstand the Temperature created by this high efficient output fire and may discolour and/or create an odour.
- b. A suitable rebated Fire Surround may be used, however check the fires depth requirement and compare with the rebate available.
- c. The Fire requires a non-combustible Hearth of 50mm high level with the fireplace opening and consisting of a top of at least 12mm thick.
- d. The Hearth must project at least 300mm in front of the fireplace opening and 150mm either side (700mm minimum hearth width).  
**Note: For Arc & Standen Trims if the Hearth as an Upstand it Must Not be higher than 15mm or the Controls Door will Not Open.**
- e. The base of the fireplace must be flat, level and square to the face of the fireplace opening.
- f. There must be a minimum flat surface around the Fireplace Opening allowing 610mm high by 510mm wide (or for Profile Trims 630mm High x 560mm wide) This is essential in order to achieve a good sealing and fitting of the trims.
- g. The Fire Surround and Back Panel must be fully sealed to the Fireplace Opening to ensure the fireplace is sealed and prevent odours.
- h. Gaps between the Surround Back Panel and wall Must be sealed off to prevent temperature creating odours from the surround.
- i. The Fireplace Opening should have provision for a gas supply through the rear, see Section 10 Gas Supply.
- j. Dependant on the Control specified the fire may be fitted with Electronic Equipment, which is sensitive to dampness and high humidity so it is **very important** that any rendering/building work is allowed to thoroughly dry out before Installation.

**! IMPORTANT NOTE !** Dry lined walls - ensure that any air gaps between the back of the plasterboard and wall are sealed around the builders opening or fireplace as this can cause overheating of the wall, wall staining and reduce the heat output of the fire.

## 11.3 - FIREPLACE ENCLOSURE REQUIREMENTS FOR FIRE SURROUNDS

- a. The fire can be installed in a suitably sized Masonry Fireplace Enclosure or suitable studwork construction, see Section 11.1.
- b. It is recommended that a qualified builder or joiner constructs the Fireplace Enclosure.
- c. For Masonry Constructions it is recommended that a lintel is fitted first before the Fireplace opening is cut out.  
A structural survey may be required.
- d. For Combustible Installations (e.g. Wood-Studwork) any materials **Must** be 100mm Minimum from any part of the fire.
- e. Any facial Plaster Board around the opening to be cut back 25mm with any gap between it and the wall to be sealed off.
- f. Any Enclosure /Void Must be provided with inlet and outlet vents equal to 50mm square allowing cooler air to ventilate the enclosure and stop temperature building up resulting in damage to the wall, overheating of the fire/controls and possibility of odours.
- g. The fire Must Not be wrapped in any form of insulation materials e. g. Fibre Glass/Rockwool.
- h. The Front Opening sizes should be as shown in the diagram, Section 11.1.
- i. The base of the Fireplace Enclosure must be flat, level and square to the wall and it **MUST** be strong enough to support the fire.
- j. Where the Cavity forms part of the Fireplace Enclosure then any Cavity Wall Insulation should be pushed back and retained.  
**Note: If the fire passes into the Cavity a drip/weather shield Must be provided to prevent rain/damp bridging the cavity.**
- k. A Hole for the flue of 160mm diameter should be centrally cut at a height of 454mm from the base of the Enclosure/Hearth level.  
See Section 11.1 and Cutting the Hole detailed below.
- l. The fireplace opening should have provision for a gas supply through the rear, see Section 10 Gas Supply.
- m. Dependant on the Control specified the fire may be fitted with Electronic Equipment, which is sensitive to dampness and high humidity so it is **very important** that any rendering/building work is allowed to thoroughly dry out before installation.

**NOTE: Take Care Not To Use Materials That Will Give Off An Odour As This Issue Is Known To Result In Complaints And Is Difficult To Resolve. Do not use Fibreglass/Rockwool Insulation as binders can cause an odour.**

## 11.4 - FALSE CHIMNEY BREAST APPLICATION

- a. If it is decided to use a false Chimney Breast to accommodate the depth of the fire then the details for materials, sizes, clearances and diagrams are as detailed in Section 11.1.
- b. We also recommend that ventilation openings/grilles are added to ventilate the void of the False Chimney Breast at high and low Level. This will allow the cooler room air to circulate around the void of the Chimney Breast, which will reduce temperatures and assist with wall coverings applied to the Chimney Breast.

## 11.5 - CLEARANCES TO COMBUSTIBLE MATERIALS AND SHELVES (Ref: Diagram in Section 11.1)

- a. A **non combustible** shelf can be fitted above the fire and should be positioned at least 95mm above the builders opening.  
We recommend the depth of the shelf should be a maximum of 75mm as anything deeper will reduce convection air and the efficiency of the fire. For deeper non-combustible shelves they must be raised a further 25mm for every extra 25mm of depth.
- b. A 150mm **combustible** shelf can be fitted above the fire but must be positioned at least 250mm above the builders opening (805mm minimum from base of fireplace opening). For deeper combustible shelves they must be raised a further 25mm for every extra 25mm of depth.
- c. Any combustible sidewall must be 500mm from the inside of the builders/fireplace opening, however with a combustible fire surround it can be 150mm from the inside of the builders/fireplace opening provided it does not protrude more than 150mm and this must be increased by 25mm for every extra 25mm of depth.
- d. With all heating appliances, soft furnishings, decorations and wall coverings may discolour or scorch if placed too close.
- e. No combustible material, e.g. curtains must be closer than 500mm to the builders opening.
- f. Any combustible wall claddings (wall paper) must be cut back to a height of 750mm and 300 mm either side of the Fireplace Opening.
- g. Due to the heat output of The Vitesse B.F. it is **not recommended** to use blown vinyl wall covering around the fire.

## 11.6 – CUTTING THE HOLE FOR THE FLUE

The flue is 150mm in diameter, and we recommend a 160mm diameter hole for sufficient clearance. The following Notes will assist:

- a. If cutting the hole with a core drill ensure the pilot hole is cutting into solid material as it may wander.
- b. Partially drill the hole and then check the fit of the flue before finishing,( a Wall Plate is provided for the outside).
- c. For cutting out the hole with a chisel, first pilot drill the hole centreline then mark out the hole on both inside/outside and use small holes around the hole before cutting out with the chisel and making good the hole,( a Wall Plate is provided for the outside).
- d. Ensure the hole is horizontal, round and straight.
- e. Any Cavity Wall insulation must be trimmed and sealed back from the hole by at least 50mm to prevent contact with the flue and odours.

**NOW PROCEED TO SECTION 14 - PREPARING THE FIRE & FLUE.**



## 12. - HOLE IN THE WALL APPLICATIONS ( Using a Wall Frame or Marble, Slate or Stone Slips) FIREPLACE CONSTRUCTION, HOLE POSITION, SIZING & CUTTING THE FLUE.

### 12.1 - FRAME, SLIPS & WALL COVERINGS

**Nu-Flame does not recommend the use of a 1 piece back panel as cracking can occur.**

It is essential to use a frame or marble, slate or stone slips, fitted around the builders opening. The slips must have a temperature rating of 150°C and be 20mm (min) thick and typically form a border round the opening of 100mm. In order to direct the flow of heated air away from the wall we recommend that a non combustible shelf (lip) is fitted above the top frame/slip, protruding 30mm beyond the front face of the slip – see diagram in Section 14.3. If the property is dry lined (gap behind plasterboard) we recommend that the shelf is set back into the wall to seal off any air gap, this will help to reduce temperatures on the chimney breast above the fire.

With any form of heating appliance convection air will rise up through the fire carrying particles of dust that will in time result in varying degrees of wall staining. The non-combustible shelf is designed to minimise this by deflecting the airflow away from the wall. However, over time some staining might occur and we therefore suggest not using patterned paper around the fire.

Due to the heat output of The Vitesse B.F. it is **not recommended** to use blown vinyl wall covering around the fire.

Where the Chimney Breast is made of Stone or Slate or other Suitable Non Combustible Material with NO wall coverings then a Frame or Slips are Not Required but the Dimensions of the Builders Opening must be as shown below and a Flat Surface of at least 50mm must be provided around the opening for sealing.

**Nu-Flame will not accept responsibility for Cracked Slips due to Drill Fixing always use Cable Fixing.**

### 12.2 - HOLE IN THE WALL APPLICATION (Using a Wall Frame or Marble, Slate, or Stone Slips & Shelf)

**MASONRY FIREPLACE ENCLOSURE FOR  
HOLE IN THE WALL APPLICATIONS WITH  
SLIPS**

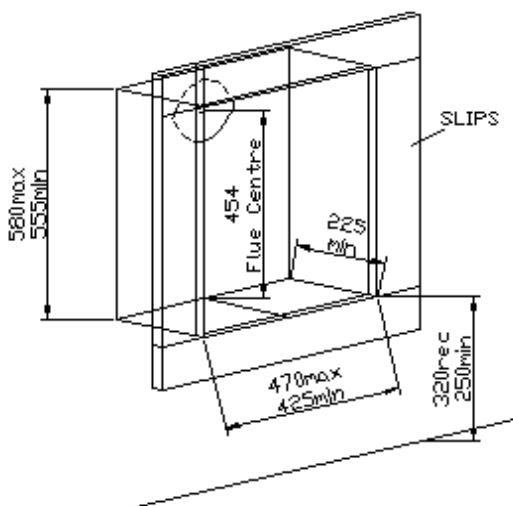

**COMBUSTIBLE FIREPLACE ENCLOSURE  
FOR COMBUSTIBLE HOLE IN THE WALL  
APPLICATIONS WITH STUDWORK &  
SLIPS**

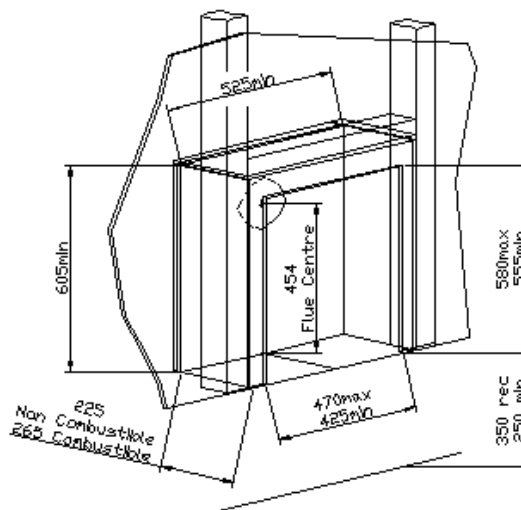

- a. The fire can be installed in a suitably sized Masonry Fireplace Enclosure or suitable studwork construction, see above.
  - b. We recommended that a qualified builder or joiner constructs the Fireplace Enclosure.
  - c. For Masonry Constructions it is recommended that a lintel is fitted first before the Fireplace opening is cut out.  
A structural survey may be required.
  - d. For Combustible Installations (e.g. Wood-Studwork) any materials **Must** be 100mm Minimum from any part of the fire.
  - e. Any facial Plaster Board around the opening to be cut back 25mm with any gap between it and the wall to be sealed off.
  - f. Any Enclosure /Void Must be provided with inlet and outlet vents equal to 50mm square allowing cooler air to ventilate the enclosure and stop temperature building up resulting in damage to the wall, overheating of the fire/controls and possibility of odours.
  - g. The fire Must not be wrapped in any form of insulation materials e. g. Fibre Glass/Rockwool.
  - h. The Front Opening sizes should be as shown in the diagram, Section 11.1.
  - i. The base of the Fireplace Enclosure must be flat, level and square to the wall and it **MUST** be strong enough to support the fire.
  - j. Where the Cavity forms part of the Fireplace Enclosure then any Cavity Wall Insulation should be pushed back and retained.
- Note: If the fire passes into the Cavity a drip/weather shield Must be provided to prevent rain/damp bridging the cavity.**
- k. The flue is 150mm (6") Diameter, we recommend a hole of 160mm diameter for clearance and should be centrally cut at a height of 454mm from the base of the Enclosure/Hearth level. See Section 11.1 and Cutting the Hole as detailed on the next page.
  - l. The builders opening should have provision for a gas supply through the rear, see Section 10 Gas Supply.
  - m. There must be a flat surface around the builders opening of sufficient area to enable the slips to be securely fitted. The slips should be fitted to the wall in such a way that they form a seal to stop air from the room being drawn behind the slips into the builders opening.  
We recommend a high temperature silicon sealant.
  - n. Dependant on the Control specified the fire may be fitted with Electronic Equipment, which is sensitive to dampness and high humidity so it is **very important** that any rendering/building work is allowed to thoroughly dry out before installation.

**NOTE: Take Care To Seal Off The Areas Indicated and Not To Use Materials That Will Give Off An Odour When Hot  
As This Issue Is Known To Result In Complaints And Is Difficult To Resolve.**

- o. The **recommended** height for the base of the Builders Opening is 320mm above floor level. The **minimum** height for the base of the Builders Opening is 250mm above floor level.
- p. Dependant on the Control specified the fire may be fitted with Electronic Equipment, which is sensitive to dampness and high humidity so it is **very important** that any rendering/building work is allowed to thoroughly dry out before installation.

**! IMPORTANT NOTE !**

Dry lined walls - ensure that any air gaps between the back of the plasterboard and wall are sealed around the builders opening or fireplace as this can cause overheating of the wall, wall staining and reduce the heat output of the fire.

**12.4- FALSE CHIMNEY BREAST APPLICATION**

- a. If it is decided to use a false Chimney Breast to accommodate the depth of the fire then the details for materials, sizes, clearances and diagrams are as detailed in this Section.
- b. We also recommend that ventilation openings/grilles are added to ventilate the void of the False Chimney Breast at high and low Level. This will allow the cooler room air to circulate around the void of the Chimney Breast, which will reduce temperatures and assist with wall coverings applied to the Chimney Breast.

**Hole in the Wall Installation With Slips and Non Combustible Shelf**

**12.5 - CLEARANCES TO COMBUSTIBLE MATERIALS**

- a. Any combustible sidewall must be at least 500mm from the inside of the builders/fireplace opening.
- b. With all heating appliances, soft furnishings, decorations and wall coverings may discolour or scorch if placed too close.
- c. No combustible material, e.g. curtains must be closer than 500mm to the builders opening.
- d. Due to the heat output of The Vitesse B.F. we do **not recommend** the use of blown vinyl wall coverings around the fire.

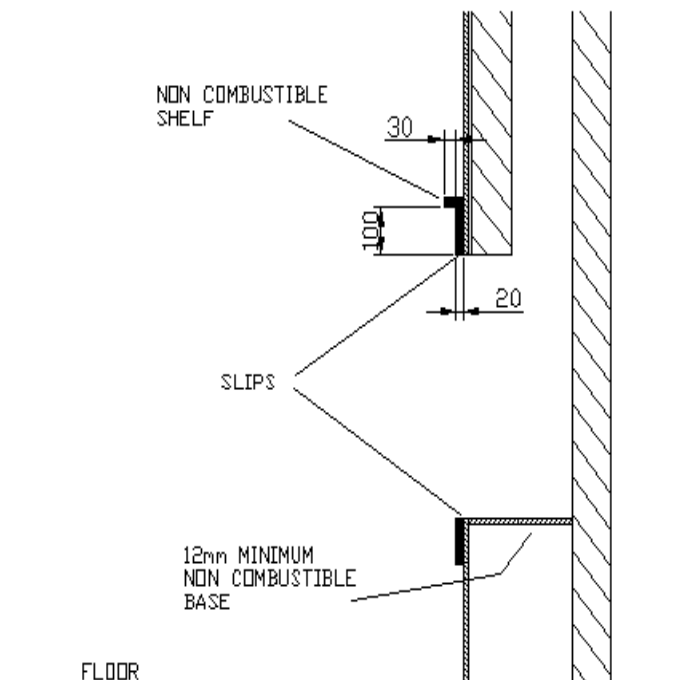

**12.6 – CUTTING THE HOLE FOR THE FLUE**

The flue is 150mm in diameter, we recommend a 160mm diameter hole for sufficient clearance. The following Notes will assist:

- a. If cutting the hole with a core drill ensure the pilot hole is cutting into solid material as it may wander.
- b. Partially drill the hole and then check the fit of the flue before finishing, (a Wall Plate is provided for the outside).
- c. For cutting out the hole with a chisel, first pilot drill the hole centreline then mark out the hole on both inside/outside and use small holes around the hole before cutting out with the chisel and making good the hole, (a Wall Plate is provided for the outside).
- d. Ensure the hole is horizontal, round and straight.
- e. Any Cavity Wall insulation must be trimmed and sealed back from the hole by at least 50mm to prevent contact with the flue.

**NOW PROCEED TO SECTION 14 - PREPARING THE FIRE & FLUE.**

### 13. - TIMBER FRAME INSTALLATION OPTIONS REQUIREMENTS FOR FIRE SURROUND & HOLE IN THE WALL APPLICATIONS.

With installations in Timber Frame Houses, because the fire is to be installed into a Building Constructed of mainly Combustible Materials, emphasis must be made of the need to ensure that adequate Fire Protection is provided with Minimum Safe Distances from any Combustible material.

The construction and depth of the wall, excluding the cavity, needs to be considered first to see what is required to accommodate the depth of the fire. The different types of Wall Construction provide different depths available for the fire, and a False Chimney Breast, Rebated Fire Surround, and/or a localised built-out structure to space away a Surround may be required.

It is therefore advised that you read this whole Section as some Installation Options may not be possible.

**Important Note : The cavity cannot be used to accommodate the main body of the fire.**

Nu-Flame may not have every solution for every Timber Frame Installation but we are certainly available for consultation.

#### 13.1 - FIREPLACE ENCLOSURE GENERAL REQUIREMENTS FOR FIRE SURROUND WITH FALSE CHIMNEY BREAST AND HOLE IN THE WALL INSTALLATIONS

- Before starting any Installation you **MUST** seek the advise of your Local Building Control Authority, and Builder and or Architect.
- Reference **MUST** also be made to British Gas, publication documents DM2 & DM3, 'Guide for Installation in Timber Frame Housing' and the Institute of Gas Engineers Document 1GE/UP/7.
- You are advised that if the property is covered by an NHBC Warranty then they should be consulted for advice about the proposed Installation.
- Installation **MUST** take account of the Outer Wall Cladding be it Brick or Weather Boards, the latter being combustible will require different Installation Requirements. We recommend seeking advise of the Weather Board Manufacturer and discussing the recommendations of the Documents in 'b' above before proceeding
- The integrity of the VCL (Vapour Control Layer) **MUST** be maintained following the Installation.
- When considering the position for the fireplace enclosure the Structural Integrity of the Property **must** not be affected by the Installation.
- Prior to planning the position for the fire take account of the positions of studwork, plumbing and electrical wiring. Studs are structural parts of the building they should be used to support a fireplace enclosure with noggings provided minimum distances are maintained but they **MUST** not be cut or modified without consultation with the Builder, Property Designer, Architect or Structural Engineer.
- Choose a position ideally between supporting studding taking into account the positional requirements of the Flue Terminal as detailed on Page 4.
- For installations in Timber Frame Houses we do **NOT** recommend that the main body of the fire bridges the cavity.
- The Flue will have to bridge the cavity and **MUST** be enclosed in a Metal Duct providing a 50mm air gap around the flue.

#### Timber Frame Fireplace Enclosure Typical Wall Construction With Fire Surround

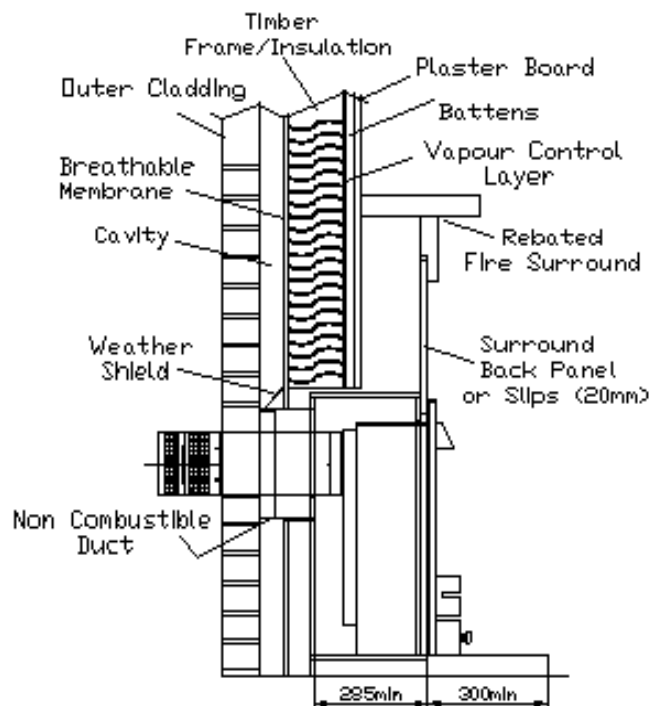

**NOTE: Take Care Not To Use Materials That Will Give Off An Odour When Hot  
As This Issue Is Known To Result In Complaints And Is Difficult To Resolve.**

- k. The VCL (Vapour Control Layer) **MUST** be resealed and a Drip/Weather Shield **MUST** be provided above the Metal Duct to prevent rain/damp bridging the cavity.
- l. The fire **MUST** be enclosed within a suitably sized enclosure mounted off the main support Studding as shown and **MUST** be lined on All sides & the Base with a Non Combustible material (e.g. Supalux or Equivalent) of at least 12mm thick. See diagrams.
- m. The Fire requires a Minimum Depth of 285mm, measured from the front face of a Fire Surround Back Panel or Slips. Dependant on the Inner Leaf depth (excluding the cavity) the Fireplace Enclosure may require additional depth, which may be accommodated by a Rebated Fire Surround for a Hearth Mounted Fire. For a Hole-in the Wall Installation a False Chimney Breast would have to be considered see 13.5. Also a localised structure/spacer could be used behind a Fire Surround to provide additional depth.
- n. The Fireplace Opening should have provision for a gas supply through the rear, see Section 10 Gas Supply, reference should be made to the documents mentioned in 'b' of this Section for details on how best to provide a gas supply within a Timber Framed Property. When constructing the Fireplace Enclosure ensure that you account for the thickness of the insulated base as it must finish level with the Hearth.

### FIREPLACE ENCLOSURE FOR TIMBER FRAME MINIMUM SIZES FOR FIRESURROUND APPLICATION

**Note: There Must Be NO Combustible Material Within The Fireplace Enclosure.**

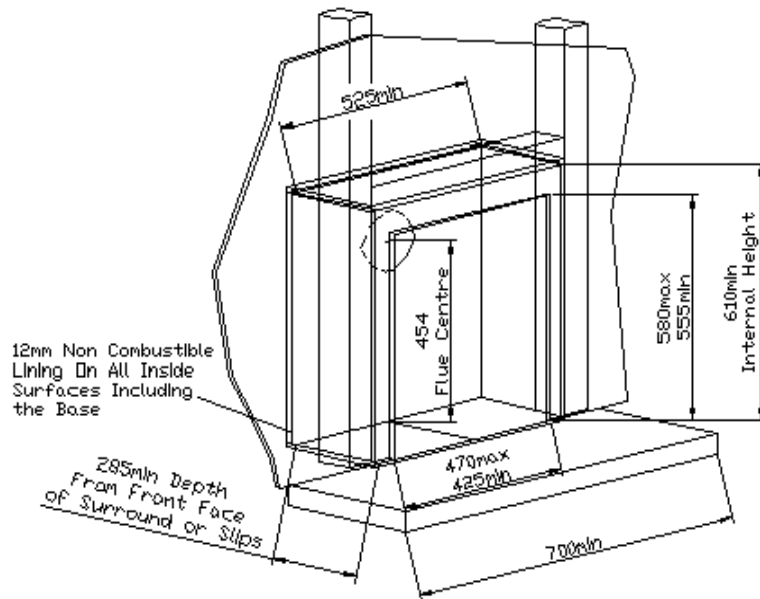

### 13.2 - FIRE SURROUND REQUIREMENTS (See diagram in Section 13.1)

- a. If the Fire is to be fitted into a purpose made Fire Surround it must have a temperature rating of 150°C. Also due to the possibility of cracking we recommend that the Back Panel of the Surround is made of 3 pieces, top and sides. Some back panel materials, (Conglomerate), claiming a 150C rating may still not withstand the Temperature created by this high efficient output fire and may discolour and/or create an odour.
- b. A suitable rebated Fire Surround may be used, however check the fires depth requirement and compare with the rebate available.
- c. The Fire requires a non-combustible Hearth of 50mm high level with the fireplace opening and consisting of a top of at least 12mm thick.
- d. The Hearth must project at least 300mm in front of the fireplace opening and 150mm either side (700mm minimum hearth width).  
**Note: For Arc & Standen Trims if the Hearth as an Upstand it Must Not be higher than 15mm or the Controls Door will Not Open.**
- e. The base of the fireplace must be flat, level and square to the face of the fireplace opening.
- f. There must be a minimum flat surface around the Fireplace Opening allowing 610mm high by 510mm wide (or for Profile Trims 630mm High x 560mm wide) This is essential in order to achieve a good sealing and fitting of the trims.
- g. The Fire Surround and Back Panel must be fully sealed to the Fireplace Opening to ensure the fireplace is sealed and prevent odours.
- h. Gaps between the Surround Back Panel and wall Must be sealed off to prevent temperature creating odours from the surround.
- i. The Fireplace Opening should have provision for a gas supply through the rear, see Section 10 Gas Supply.
- j. Dependant on the Control specified the fire may be fitted with Electronic Equipment, which is sensitive to dampness and high humidity so it is **very important** that any rendering/building work is allowed to thoroughly dry out before Installation.

**! IMPORTANT NOTE !** Dry lined walls - ensure that any air gaps between the back of the plasterboard and wall are sealed around the builders opening or fireplace as this can cause overheating of the wall, wall staining and reduce the heat output of the fire.

**! IMPORTANT NOTE !** Ensure the VCL (vapour Control Layer) is resealed as it will be affected by the Installation.

### 13.3 - FALSE CHIMNEY BREAST APPLICATION

- a. If it is decided to use a false Chimney Breast to accommodate the depth of the fire then the details for materials, sizes, clearances and diagrams are as detailed in Section 13.1.
- b. We also recommend that ventilation openings/grilles are added to ventilate the void of the False Chimney Breast or localised Spacing Structure at high and low Level. This will allow the cooler room air to circulate around the void of the Chimney Breast, which will reduce temperatures and assist with wall coverings applied to the Chimney Breast.

### 13.4 - CLEARANCES TO COMBUSTIBLE MATERIALS AND SHELVES

- A **non combustible** shelf can be fitted above the fire and should be positioned at least 95mm above the builders opening. We recommend the depth of the shelf should be a maximum of 75mm as anything deeper will reduce convection air and the efficiency of the fire. For deeper non-combustible shelves they must be raised a further 25mm for every extra 25mm of depth.
- A 150mm **combustible** shelf can be fitted above the fire but must be positioned at least 250mm above the builders opening (805mm minimum from base of fireplace opening). For deeper combustible shelves they must be raised a further 25mm for every extra 25mm of depth.
- Any combustible sidewall must be 500mm from the inside of the builders/fireplace opening, however with a combustible fire surround it can be 150mm from the inside of the builders/fireplace opening provided it does not protrude more than 150mm and this must be increased by 25mm for every extra 25mm of depth.
- With all heating appliances, soft furnishings, decorations and wall coverings may discolour or scorch if placed too close.
- No combustible material, e.g. curtains must be closer than 500mm to the builders opening.
- Any combustible wall claddings (wall paper) must be cut back to a height of 750mm and 300 mm either side of the Fireplace Opening.
- Due to the heat output of The Vitesse B.F. it is **not recommended** to use blown vinyl wall covering around the fire.

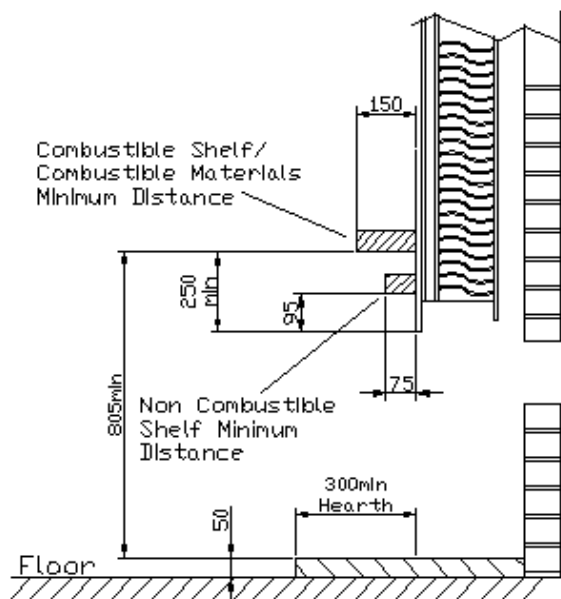

### 13.5 - HOLE IN THE WALL INSTALLATION (USING a Fame MARBLE, SLATE or STONE SLIPS & SHELF) REFER ALSO TO SECTION 13.1

You Must Read The Whole Of Section 13 'Timber Framed Installations' Prior To Any Construction/Installation.

**Nu-Flame does not recommend the use of a 1 piece back panel as cracking can occur.**

It is essential to use marble, slate or stone slips, fitted around the builders opening. The slips must have a temperature rating of 150°C and be 20mm (min) thick and typically form a border round the opening of 100mm. In order to direct the flow of heated air away from the wall we recommend that a non combustible shelf (lip) is fitted above the top slip, protruding 30mm beyond the front face of the slip – see diagram in Section 13.6. If the property is dry lined (gap behind plasterboard) we recommend that the shelf is set back into the wall to seal off any air gap, this will help to reduce temperatures on the chimney breast above the fire.

With any form of heating appliance convection air will rise up through the fire carrying particles of dust that will in time result in varying degrees of wall staining. The non-combustible shelf is designed to minimise this by deflecting the airflow away from the wall. However, over time some staining might occur and we therefore suggest not using patterned paper around the fire.

Due to the heat output of The Vitesse B.F. it is **not recommended** to use blown vinyl wall covering around the fire.

Where the Chimney Breast is made of Stone or Slate or other Suitable Non Combustible Material with **No** wall coverings then Slips are Not Required but the Dimensions of the Builders Opening must be as shown below and a Flat Surface of at least 50mm must be provided around the opening for sealing.

**Nu-Flame will not accept responsibility for Cracked Slips due to Drill Fixing always use Cable Fixing.**

**For Hole In The Wall Installations See Diagram For Minimum Sizes of Non Combustible Enclosure on Next Page**

- Due to the limit of depth available within a typical Timber Framed Property additional depth in the form of a False Chimney Breast will be required to accommodate the depth of the fire. The requirements for False Chimney Breasts are covered in Section 13.6.
- Prior to planning the position for the fire take account of the positions of studwork, plumbing and electrical wiring. Studs are structural parts of the building they should be used to support a fireplace enclosure with noggings provided minimum distances are maintained but they **Must** not be cut or modified without consultation with the Builder, Property Designer, Architect or Structural Engineer.
- The base of the Fireplace Enclosure must be flat, level and square to the wall and it **MUST** be strong enough to support the fire.
- A Hole for the flue should be centrally cut at a height of 454mm from the base of the Enclosure. See Cutting the Hole.
- The builders opening should have provision for a gas supply through the rear, see Section 10 Gas Supply.
- There must be a flat surface around the builders opening of sufficient area to enable the slips to be securely fitted. The slips should be fitted to the wall in such a way that they form a seal to stop air from the room being drawn behind the slips into the builders opening. We recommend a high temperature silicon sealant.
- The **recommended** height for the base of the Builders Opening is 320mm above floor level. The **minimum** height for the base of the Builders Opening is 250mm above floor level. See Diagram on next page.
- Dependant on the Control specified the fire may be fitted with Electronic Equipment, which is sensitive to dampness and high humidity so it is **very important** that any rendering/building work is allowed to thoroughly dry out before Installation.

## HOLE IN THE WALL INSTALLATION - FIREPLACE ENCLOSURE MINIMUM SIZES

**Note: There Must Be NO Combustible Material Within The Fireplace Enclosure.**

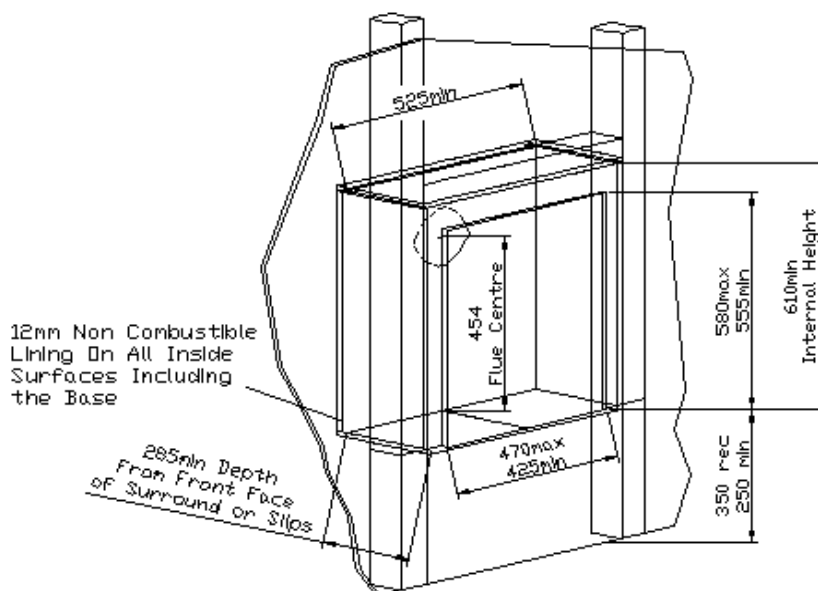

## HOLE IN THE WALL INSTALLATION WITH SLIPS AND NON COMBUSTIBLE SHELF

### 13.6 - CLEARANCES TO COMBUSTIBLE MATERIALS AND NON COMBUSTIBLE SHELF WITH SLIPS

- Any combustible sidewall must be at least 500mm from the inside of the builders/fireplace opening.
- With all heating appliances, soft furnishings, decorations and wall coverings may discolour or scorch if placed too close.
- No combustible material, e.g. curtains must be closer than 500mm to the builders opening.
- Due to the heat output of The Vitesse B.F. we do **not recommend** the use of blown vinyl wall coverings around the fire.
- The slips must have a temperature rating of 150°C and be 20mm (min) thick and typically form a border round the opening of 100mm.
- In order to direct the flow of heated air away from the wall we recommend that a non combustible shelf (lip) is fitted above the top slip, protruding 30mm beyond the front face of the slip – see diagram.

If the property is dry lined (gap behind plasterboard) we recommend that the shelf is set back into the wall to seal off any air gap, this will help to reduce temperatures on the chimney breast above the fire.

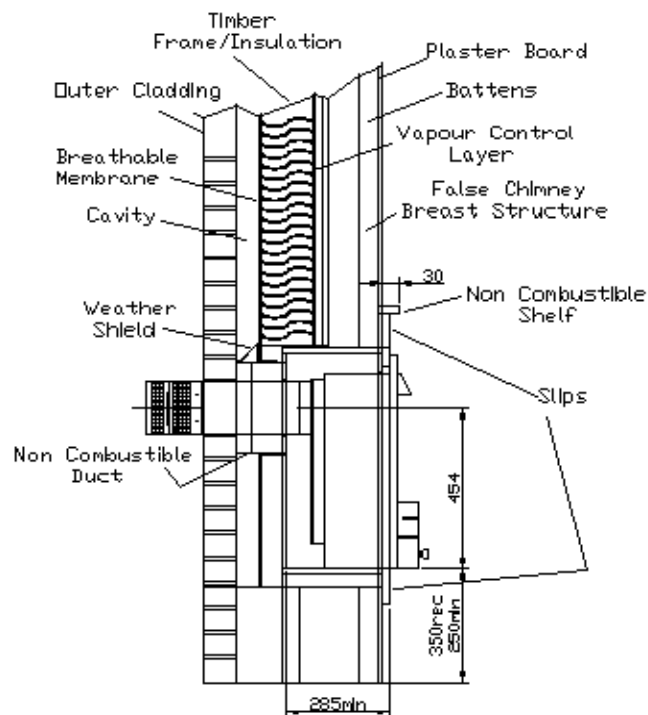

### 13.7 - CUTTING THE HOLE FOR THE FLUE

The flue is 150mm in diameter, we recommend a 160mm diameter hole provide sufficient clearance. The following Notes will assist:

- With a Timber Frame House it is recommended to firstly determine the best position for the fire enclosure ideally between supporting studs and check for any services like electrical wiring or plumbing.
- Mark out the Centre Line of the Flue Hole position see Section 13.1 taking account of the height of the Hearth (typically 50mm) for a Fire Surround Application and the recommended Minimum Height for a Hole in the Wall Application (Minimum 250mm, recommended 320mm).
- Pilot drill the hole from the inside then working outside, if core drilling, ensure the pilot hole is cutting into solid material as it may wander.
- Partially drill the hole and then check the fit of the flue before finishing, (a Wall Plate is provided for the outside).
- For cutting out the hole with a chisel, first pilot drill the hole as detailed in 'b' then working outside mark out the hole and use a small holes around the hole before cutting out with the chisel and making good the hole, (a Wall Plate is provided for the outside).
- For a Weather Board Clad House use the same methods as above but cut out the hole with a jig saw or equivalent.
- IMPORTANT**- although a Wall Plate is provided additional protection will be required for any combustible Weatherboard Cladding - seek advice as stated in Section 13.1 'a' and 'b'.
- Ensure the hole is horizontal, round and straight..
- Any Cavity Wall insulation must be trimmed and sealed back from the hole above the Flue Duct see Section 13.1.

**NOW PROCEED TO SECTION 14 - PREPARING THE FIRE & FLUE.**

## 14a. - PREPARING THE FIRE .

**For Fires ordered Without a Wall Frame (see Sections 7b & c for Wall Frame Details)**

### Fitting The Silicone Sealing Strip

- It is very important that a good seal is achieved between the convector box and the front of the fireplace back panel to achieve maximum efficiency. Take the self adhesive silicone sealing strip from the fitting kit and neatly apply to the back flanges of the convector box (as close to the edge as possible), cutting to the appropriate lengths as required. To ensure there is a good seal between the base of the fire and the bottom of the fireplace opening apply a length of self adhesive silicone sealing strip along the base of the fire at the front edge.



**For Fires ordered With a Wall Frame (see Sections 7b & c for Wall Frame Details)**

- Follow the above Instructions first and apply the foam seal to the fire.
- Use the screws provided with the Wall Frame fix it to the back of the fire.
- Using the foam seal provided with the Wall Frame apply it to the outer rear flange of the frame as shown.  
It is very important that a good seal is achieved between the Wall Frame and the front of the fireplace back panel to achieve maximum efficiency.

## 14b. - FITTING THE ARC & STANDEN TRIM BRACKETS

The fixing brackets and screws will be supplied with the Trim. Take the 2 brackets and fix as shown. The Brackets are supplied with slots for adjustment which can be adjusted when the Trim is fitted. Two screws are also provided for fixing the Trim at the bottom right hand and left and corners



## 14c. - PREPARING THE FLUE .

### 14.1 - DETERMINING THE FLUE LENGTH

- The Standard Flue Length supplied caters for a maximum wall thickness of 500mm, and a Minimum Wall thickness of 93mm. (Total Flue Length Including Terminal = 630mm).  
**NOTE:** A Long Flue for wall thickness of up to 850mm is available.
- To find the flue length required in your application; measure the Depth from the front face of the Fireplace to the Outside Wall. For a Fire **without** a Wall Frame deduct the fire depth of 215mm. For Fires fitted with a Wall Frame deduct 200mm for a 15mm deep Wall Frame, (some Wall Frames have different depths). This will provide the flue length for your application.

Take your flue length dimension from 500mm, (Standard flue length provided), and this is the length you will need to cut off the flue. See Diagram with Example.

Note : Where the Long 850mm Flue is being used take your flue length Dimension from 850mm, (Long flue length).

- From the open end of the flue mark the cut off dimension, position the cutting aid in the flue central about the cut line and cut the flue, ensuring it is cut square; remove any sharp edges.

**IMPORANT: Remove the Cutting Aid Material from inside the Flue.**



Cutting Aid

**FLUE LENGTH DIAGRAM – EXAMPLE**  
**Fire Depth for Fire Without a Wall Frame deduct = 25mm.**  
**Fire Depth or Fire With Wall Frame deduct = 200mm.**  
 Therefore Inside Wall to Outside Wall Dimension was 595mm  
 Example - So for a fire without a Wall Frame deduct the Fire Depth of 215mm:  
 $595\text{mm} - 215\text{mm} = 380\text{mm}$   
 Take this from the 500mm Flue Length Supplied:  
 $500\text{mm} - 380\text{mm} = 120\text{mm}$ .  
 Cut 120mm off the Open End of the Flue  
 Note: Some Wall Frames have Different Depths

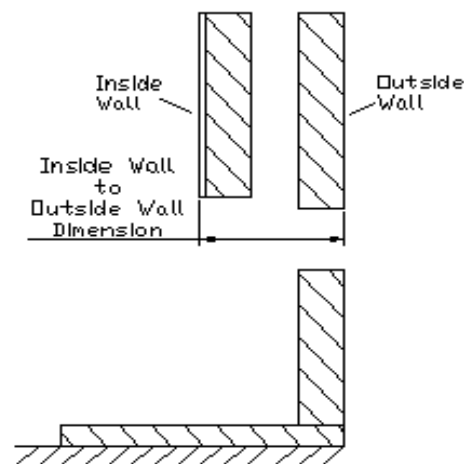

- With the flue at the correct length and when the fire is fitted there should be 130mm of Flue Terminal Outside The Wall and the screw holes for fixing the Wall Plate should line up with those in the Flue Terminal. See photographs on page 16.

**! IMPORTANT NOTE! NONE OF THE SQUARE HOLES IN THE FLUE TERMINAL MUST BE WITHIN THE WALL.**

**! TIP !** To provide a good square cut end to the flue, working from the Open end of the flue; place 5 marks around the flue and using a tape measure coiled around the flue mark a continuous line.

### **! IMPORTANT NOTES!**

- Numerous problems occur because the cutting aid is not removed after cutting the flue.
- Numerous problems occur because the correct length of the flue is not first determined and the square cut outs in the flue terminal are not outside the flue. Check that the Wall Plate screws can be fitted into the holes in the Flue.
- Do NOT FORCE** the flue when engaged into the flue spigot; it goes in just 40mm up to a stop and will block off the flow creating a poor flame picture and overheating if pushed in too far.

## 15. FITTING THE FIRE

**DO NOT REMOVE THE PRESSURE RELIEF DOOR CARDBOARD FITMENT AT THE TOP OF THE FIRE AT THIS STAGE.**

If The Vitesse BF is having a Flat Trim fitted the stainless steel Top Louvre / Heat Shield must be fitted with the 2 # No6 x 5mm blunt self tapping screws before fitting the convector box into the opening. Screw through the top of the case into the Top Louvre / Heat Shield. The Top Louvre / Heat Shield is packed in the same box as the Flat Trim and the fixing screws are in with the fitting kit packed with the Main Convector. **Note:** The Top Louvre / Heat Shield is not needed if a Curved Trim is being used.

**Do not remove the Pressure Relief Door Cardboard Packer and Label yet. The Packer is to hold the Pressure Relief Door Closed at this stage.**

**Top Louvre / Heat Shield.**  
Only needed if a trim with a louvred top is being used. Not required if a trim with a canopy top is being used.

**View Pressure Relief Door through here.**

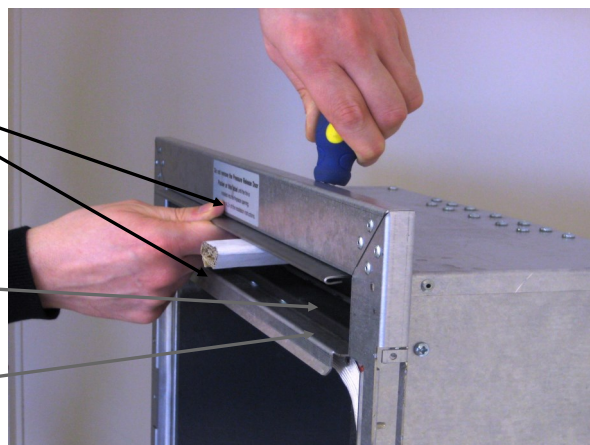

### 15.1 - FITTING THE Silicone Sealing Strip

It is very important that a good seal is achieved between the back of the convector box outer frame and the front of the fireplace back panel to achieve maximum efficiency. Take the self adhesive silicone sealing strip from the fitting kit and neatly apply to the back flanges of the convector box outer frame (as close to the edge as possible), cutting to the appropriate lengths as required. To ensure there is a good seal between the base of the fire and the bottom of the fireplace opening apply a 410mm length of self adhesive silicone sealing strip on the base of the fire at the front edge.

### 15.2 - FITTING THE FIRE - reference should be made to the Cable Fixing Diagrams on the next page.

**! IMPORTANT NOTE !** TAKE GREAT CARE WHEN WORKING INSIDE THE FIRE NOT TO MARK THE CERAMIC LINING PANELS.

- a. Using a Dust Sheet or equivalent protect the area around the Fire Installation.
- b. Remove the Fire from the box and lay it on its back. Using the Screw Driver provided remove the 5 special countersunk crews at the Bottom and Sides Securing the Glass Panel then tilt the Glass Panel outward slightly at the base then slide down and remove.
- c. Now with the fire upright on its Base, remove the 4 screws holding the Burner/Control Assembly at the 4 corners taking care not to mark the liners. With the Thermatronic/High Level Controls remove the Heat Shield; a single screw fixing at the right. Carefully lift the Burner Assembly upward then roll out from the back to remove, taking care not to Mark the Liners. If the fire is fitted with the Thermatronic Control it will be necessary to pull the Receiver Box and Infrared Sensor off its Velcro Pads. If fitted with the High Level Control then pull the Battery Box off its Velcro Pad.
- d. There are fixing holes in the front flanges which can be used if there is sufficient strong material for fixing, however we recommend the cable fixing system which is supplied to secure the unit to the fireplace. The cable fixing system will also pull the unit tight back against the slips to make a good seal. This is very important to ensure efficient and safe operation of the fire.  
**See Cable Fixing Diagrams on next page.**
- e. There are 2 cables supplied; 1 to be used each side of the unit. Working at 360mm centres in the fireplace enclosure drill the lower holes 27mm up from the base and drill the higher holes 510mm up from the base (see Cable Fixing Diagrams on next page) . Secure the 4 Eyebolts supplied with the Rawlplugs to the back of the fireplace. Ensure the Eyebolts are fully screwed in. **IMPORTANT: ENSURE THE MATERIAL THE EYEBOLT/RAWPLUG IS FIXED INTO IS SOLID AND SOUND.** If the fixing is not sound the Rawlplug/Eyebolt will be pulled out and the fire will not be sealed to the Fireplace Opening.  
**Note: With the minimum depth fireplace enclosure it may be necessary to sink the Eye Bolt Heads into the Brickwork.**
- f. There are 2 cable attachment tabs on the top of the main casing; 1 each side at the rear. They are part of the folded down lip of the case, prize these up with a screwdriver to enable them to be used. Feed a cable downwards through each cable attachment point ready for the next stage of Installing the fire.
- g. Push the Flue onto the Spigots at the rear of the fire and **IMPORTANT**, ensure that 'TOP' marked on the end of the Flue Terminal is at the top centre; using the drill provided and with the flue level, mark and drill the three holes around the Spigot. Secure the flue with the Screws provided and then seal around the flue/spigot with the Sealing Tape also provided.  
**IMPORTANT : Do Not Force The Flue In Too Far Or Past It's Stop As It Will Block Off The Flow Causing Overheating.**
- h. When fitting the fire into a Hole in the Wall Installation take care to not damage the slips, rest the Fire in the Fireplace opening so that you can still gain access to the cables and eyebolts. Feed the cables through the eyebolts on either side and then through the holes in the back of the fire near the base.
- i. Lifting the fire slightly at the base so as to not damage the base foam seal slide the Fire/Flue into the Fireplace guiding the flue into the hole until it is **part way** (leaving the fire sticking out approximately 50mm) ensuring the gas supply pipe and isolation/pressure test elbow clears through the cut out in the rear of the Main Casing. While sliding the unit into the Fireplace Opening pull on the excess cable.
- j. Now again lifting the Fire slightly, slide it home ensuring that the sealing strips on the underside of the front of the Fire and the rear of the Fire stay in position to make a seal against the fireplace enclosure. While sliding the unit into the Fireplace Opening pull on the excess cable.
- k. The Cable Fix Adjuster and Lock Screw (see Cable Fixing Diagrams on next page) can now be fitted onto the cable and tightened up to tension the fire back into the fireplace to secure the fire.



- l. If any of the silicone sealing strips are not compressed and/or if there are gaps they **must** be filled with a suitable sealant, fireclay or high temperature silicone.
- m. Now on the Outside check that the End Terminal part of the Flue is clear of the hole = 130mm of Flue, the Terminal should be clear of the wall – **NOT WITHIN THE WALL**. See photograph below.
- n. Adhere Sealing Foam to back of the Wall Plate (see **Note** below). Fit and secure the Wall Plate to the Flue through the holes provided in the flue terminal and seal to the Wall with the Stainless Steel Screws provided.  
**Note:** To prevent the ingress of water Sealing Foam has been supplied for the Wall Plate, if this does not provide an adequate seal with the wall then any gaps must be filled with a waterproof silicone sealant or mastic.  
 Note: With the flue at the correct length and when the fire is fitted there should be 130mm of Flue Terminal Outside The Wall and the screw holes for fixing the Wall Plate should line up with those in the Flue Terminal.

**! IMPORTANT NOTE !** NONE OF THE SQUARE HOLES IN THE FLUE TERMINAL MUST BE WITHIN THE WALL.

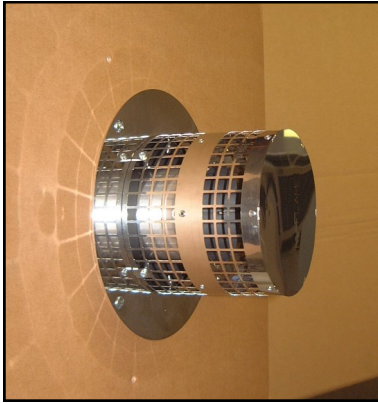

- o. Refit the Burner Assembly and secure with 4 screws, reposition the Thermatronic (Receiver Box and Infrared Sensor) or for High Level Control the Battery Box onto their Velcro Pads if applicable. Reposition Receiver/Battery Box under Heat Shield.
- p. **Now Remove the Pressure Relief Cardboard Packer and Label at the Top of the Fire. Ensure the Pressure Relief Door has remained closed (see photograph on previous page).**
- q. Connect the isolation/pressure test elbow to the control valve and with it fully open check the joint for gas soundness.
- r. Check that all gas connections are sound. The appliance has been factory tested; however the connections may have been disturbed in transit or storage.

**! IMPORTANT NOTE !** Always reseal the pressure test point and check that it is gas tight.  
(This accounts for a lot of recalls.)

## CABLE FIXING DIAGRAMS

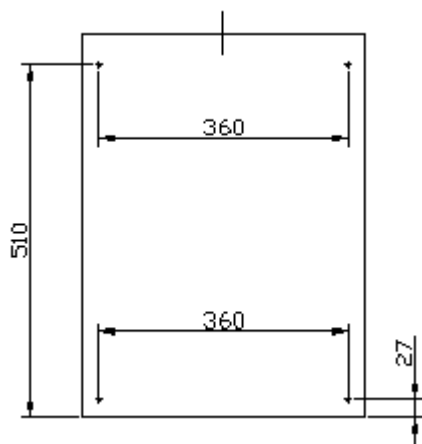

**Hole Positions in back of Fireplace Opening**

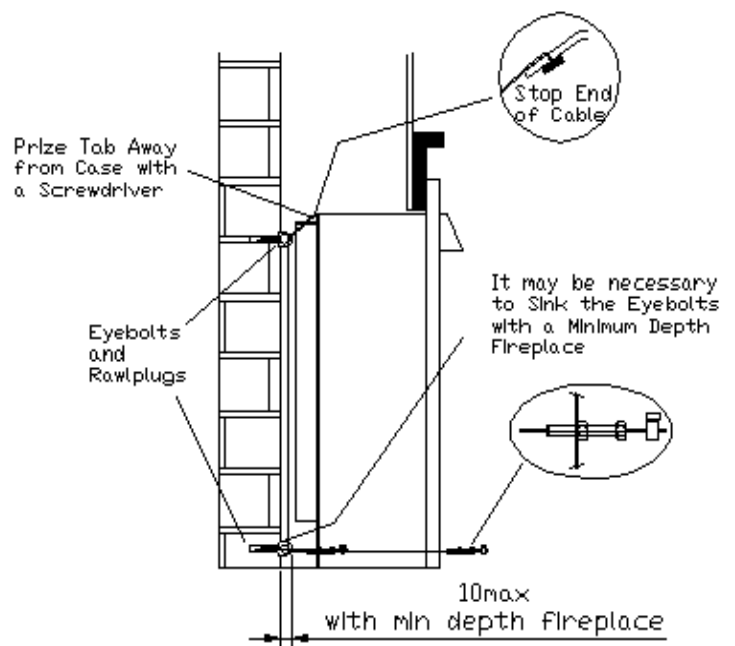

**Side View of Cable Fixing System**

## 16. - ARRANGEMENT OF THE FUEL EFFECT (COALS or PEBBLES) FOR FLAT & CURVED TRIMS

### Health & Safety Advice Refractory Ceramic Fibre (RCF)

#### Advice when working with Fuel Bed Components including Installing, Servicing and Disposal.

The Fuel Effect parts and possible Linings of this fire are made from Refractory Ceramic Fibre (R.C.F.) a Class 2 Carcinogen which is a material designed for this Application. Excessive exposure to these types of materials may cause temporary irritation to eyes, skin and respiratory tract. Therefore take care when handling these articles to ensure dust is kept to a minimum.

It is not necessary to wear protective clothing when handling these articles but we do recommend you follow the normal hygiene rules of not smoking, eating or drinking in the work area, and always wash your hands before eating or drinking.

To minimise the release of RCF fibres during installation and servicing a HEPA filtered vacuum is recommended to remove any dust accumulated in and around the fire both before and after working on it.

When Servicing and if replacing these parts we do not recommend they are broken up but are sealed within a heavy duty polythene Bag and labelled as "RCF waste". This is not classified as "hazardous waste" and may be disposed of at a local licensed landfill site.

Remove all the Fuel Effect parts & familiarise yourself with each part. The Cluster Coals & Pebbles are numbered 1-5.

**! TIP ! TAKE CARE NOT TO DAMAGE THE LINER PANELS INSIDE THE FIREWHEN FITTING THE FUEL BED .**

- a. Fit the Matrix Tray.

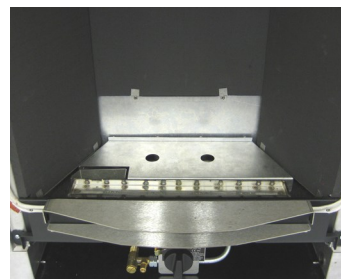
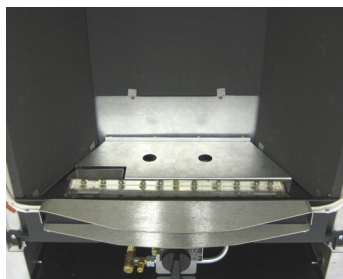

- b. Fit the Matrix onto the Matrix Tray.  
Ensure it is clear of the Burner at the left & right corners .

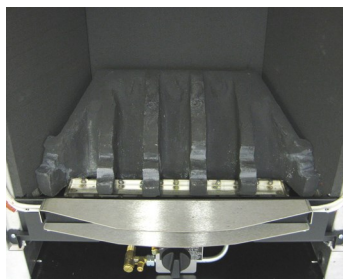

- c. Fit No1Rear Cluster Coal/Pebble.

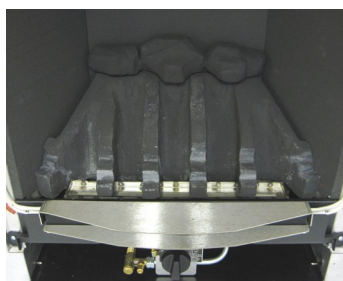

- d. Fit No2 Left Cluster Coal/Pebble.

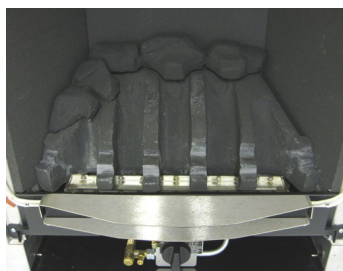

e. Fit No3 Right Cluster Coal/Pebble.

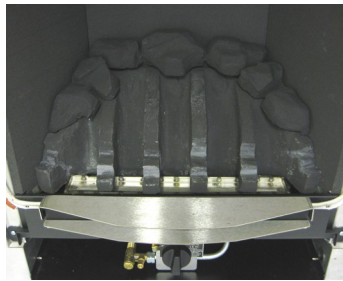

f. Fit No4 Front Cluster Coal/Pebble.

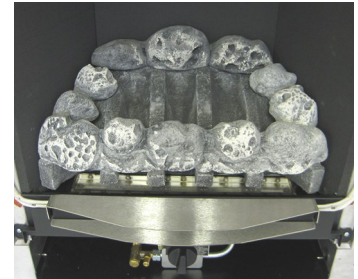
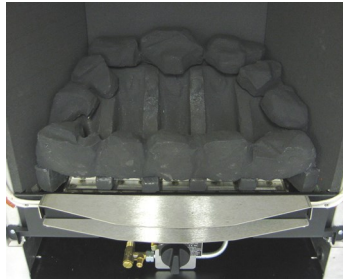

g. Fit No5 Centre Cluster Coal/Pebble.  
Note precise position of front cluster  
Relative to cut-away in front Coal/Pebble  
cluster LHS. See photo 'h' below.



h. Position of centre cluster relative to  
cut-away in front Coal/Pebble cluster LHS.

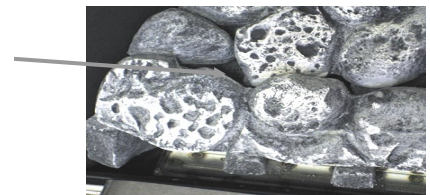

i. Before fitting the glass panel with the 5 special countersunk screws and screw driver provided, check the condition of the glass and ensure it is clean and free from any finger marks.

## 17. - FITTING THE BURNER HEAT SHIELD

There are two shapes of burner heat shield and the type you will need is determined by whether you have a Flat Trim or a Curved Trim. For this reason the appropriate Burner Heat Shield is packed with the Trim. The 2 # No6 x 10mm blunt self tapping screws to fit the trim are in with the fitting kit included with the Main Convector.

**Note - the glass panel must be in place before fitting the Heat Shield.**

*For clarity of the photograph it is shown without the glass panel.*

Screw the Burner Heat Shield to the Case just under the Glass Door. Fixings at the Right and Left sides as shown.

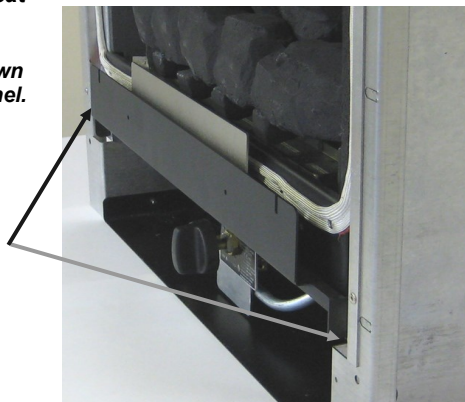

**Burner Heat Shield for Flat Trim Fitted**

**Note - the glass panel must be in place before fitting the Heat Shield.**

*For clarity of the photograph it is shown without the glass panel.*

Screw the Burner Heat Shield to the Case just under the Glass Door. Fixings at the Right and Left sides as shown.

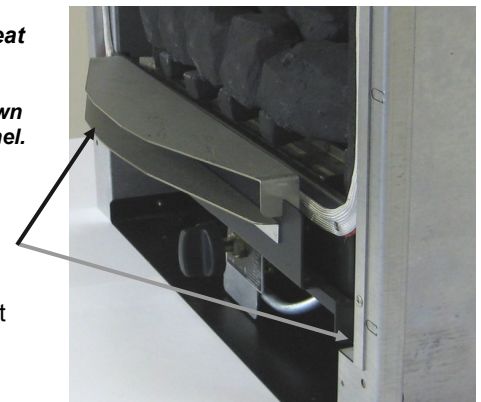

**Burner Heat Shield for Curved Trim Fitted**

### ! IMPORTANT NOTE !

Failure to fit the appropriate Burner Heat Shield will invalidate the guarantee.

## 18 - TESTING, COMMISSIONING & USE

**! IMPORTANT NOTE !** NOW REMOVE THE ORESSURE RELIEF CARDBOARD FITMENT AT THE TOP OF THE FIRE.

**! IMPORTANT NOTE !** During its first period of use any protective coatings and oils will burn out of the fire and it is wise to ventilate the room for the first hour; also advise the customer that this may persist for the first few days until the fire is fully burnt-in.

### 18.1 - LIGHTING THE FIRE

- Reference to Section 2 in the Users Instructions 'Lighting & Controlling the Fire' will show how to light and operate the fire.
- Check that the supply pressure to the fire is at the pressures required, 20mbar (Natural Gas G20) or 37mbar (Propane G31) when set at high.

**! IMPORTANT NOTE !** Ensure that the pressure test point used is sealed and gas tight.

### 18.2 - FITTING THE OUTER TRIM

**Some Trim Options are supplied separately with their own Fixings, Instructions.**

- For Trims held with magnets position the 4 strong Magnets, one at each corner.
- To fit simply centralize the Trim and fit it onto the Fire.  
Note : If the Trim is not positioned centrally it may not be held correctly at each corner, however it can be slid from side to side to ensure it is located correctly.

**IMPORTANT: Modern Flat Trim:** For Modern Trims a Stainless Steel Top Louvre / Heat Shield should have been fitted by the 2 self tapping screws before fitting the convector box into the opening. The Top Louvre / Heat Shield is packed in the same box as the Trim. See photograph at beginning of Section 15.

### Arc & Standen Trims (Fireplace or Hole in the Wall Version).

The Fixing Brackets with Screws should have already been fitted as detailed in Section 14a.

- Place the Trim over the fire and slide it downward to hook the tabs in the Trim into the slots in the Brackets on the fire.
- Take the 2 screws supplied and fix to the fire through the 2 holes, at the bottom of the Trim on each side.
- The Brackets on the fire are supplied with slots for adjustment and can be adjusted after first checking the fit of the Trim.

### 18.3 - FIREGUARDS

- A fireguard is not supplied with the appliance however it is recommended that a fireguard is fitted if the fire is to be used in the presence of young children, the elderly, the infirm and pets.
- For Hole in the Wall Installations it is recommended that a means, (tactile separator/shelf or guard) is provided to give abrupt warning to a person moving inadvertently towards the fire.

## 19 - BRIEFING THE CUSTOMER

- The installer should brief the customer on the Operation of the Control System and all aspects of the User Instructions.
- The instructions/with the Glass Panel release Screw Driver should be handed to the customer for their safe keeping and future servicing.
- Show the customer how the Trims and Glass Panel can be removed for cleaning with the screw driver provided.

**Note: Marks on the Glass Panel are Not Covered by the Manufactures Warranty.**

**It is quite normal for the push buttons on the High Level Controls to feel hot to touch.**

- For Customers who have purchased the Thermatronic or High Level Controls explain and demonstrate that the batteries in the receiver and handset , (Thermatronic) or Battery Box (High Level), should be replaced with good quality ones annually as the fire may stop working part way through the season.
- The customer should be briefed on the need for regular servicing; this will normally be once a year.
- Advise the customer that, apart from batteries for the High Level and Thermatronic System, there are no user replaceable parts in the fire but for servicing and spares to contact the local Nu-Flame Stockist.
- Advise the customer that under no circumstances must the fire be used without the glass panel fitted or if it is in any way chipped, cracked or damaged.
- Advise the Customer that the fire is fitted with a Safety Pressure Relief System and if the fires ignition should ever become delayed, or noisy then the fire **MUST NOT** be used until checked by a Qualified Engineer/Installer.
- Advise the Customer that the Glass Panel on the fire will become very hot during operation and that we recommend that a fireguard is fitted if the fire is to be used in the presence of young children, the elderly, the infirm and pets.
- Explain that due to the High Efficiency of the Fire other than the Control Knobs/Switch, Ashpan Knob and immediate surrounding areas : **All surfaces are classified as Working Surfaces and will be very hot when the fire is in operation.**
- Advise the customer about the importance of checking and maintaining the Carbon Monoxide Alarm safety device.

**! IMPORTANT NOTE ! THE GLASS PANEL ON THIS FIRE WILL BECOME VERY HOT DURING OPERATION ENSURE THE CUSTOMER IS ADVISED OF THIS.**

**! IMPORTANT NOTE ! WE STRONGLY RECOMMEND THE FITTING OF A FIREGUARD WHEN THE FIRE IS USED IN THE PRESENCE OF YOPUNG CHILDREN, THE ELDERLY, THE INFIRM & PETS.**

**It is quite normal for the push buttons on the High Level Button Controls to feel hot to touch.**

## 20 - SERVICING

The Matrix in the fire is a Moulded Ceramic Fibre component incorporating Silicone Binders and you may notice that it develops cracks during operation. This is natural shrinkage caused by exposure to high temperatures and is quite normal for the material and will in no way affect the operation of the fire.

### 20.1 - GENERAL

**Note: Servicing must be carried out by a registered installer.**

- a. The fire does not have to be removed for Servicing.
- b. Check the operation and ignition of the fire before servicing.
- c. Ensure the fire is cold before proceeding.
- d. Lay a dust sheet on the floor before proceeding.
- e. Carry out a gas soundness test before servicing.
- f. Pull off the Outer Trim and or Profile Trims (Locate the 4 magnets)( Profile Trim as 4 additional Magnets), and turn off the gas supply to the fire at the isolation/pressure test elbow.
- g. Remove the Burner Heat Shield (2 screws) see Section 17.
- h. If any parts need replacement, use only genuine parts supplied by Nu-Flame Ltd. Some components may look similar to those used in other gas fire, but these are not necessarily the same due to performance variations and must not be used.  
**This applies particularly to the Flame Failure Pilot System, Gas Control System and Ceramics.**
- i. Disconnect the gas pipe to the control.

**! TIP !** Being Magnetic The 4 Trim Magnets, (8 Profile Trim), Can Be Easily Misplaced, Locate Them Immediately.

**Remind the Customer that in the interests of Safety they MUST maintain their Carbon Monoxide Alarm.**

### 20.2 – ANNUAL SERVICING

**Carry out the operations in 20.1 General before proceeding**

**Note: Marks on the Glass Panel are Not Covered by the Manufactures Warranty.**

**! IMPORTANT NOTE ! TAKE GREAT CARE WHEN WORKING INSIDE THE FIRE NOT TO MARK THE CERAMIC LINING PANELS.**

- a. Remove the glass panel using the screwdriver provided, tilt the Glass Panel outward slightly at the base then slide down and remove. Check the Glass Panel for any damage, it must be replaced if there are any chips, cracks or any damage before the fire can be used.
- b. Referring to the Section 16, 'Arrangement of the Fuel Effect' and working in reverse order, remove the Coals or Pebbles, Matrix and the Matrix Tray.
- c. Before removing the Burner Assembly please Note that for the Thermatronic Controls and High Level Controls only, first remove the Heat Shield, (single screw fixing at the front on the right). Now for the High Level Control you will need also to disconnect the Battery Box lead. For Manual Control please read on.  
Now, working inside the fire, remove the 4 screws holding the Burner/Control Assembly at the four corners.  
Carefully lift the Burner Assembly upward then roll out from the back to remove, taking care not to Mark the Liners.  
This will now allow access to all gas carrying parts for maintenance checks, fault finding and or replacement.
- d. Brush clean the burner and pilot area of dust or debris; check that the aeration hole in the pilot is clear of dust.
- e. Refit in reverse order; brushing the coals/pebbles clean of any soot, checking gas soundness, and ignition as detailed in the relevant Sections.
- f. Check that the Flue Terminal and Guard are not damaged or covered in any way.
- g. Clean the glass panel and check it for any cracks or chips before sealing the door with the 5 special countersunk screws, (you must only use the special countersunk screws; they have shallow heads to ensure the Trim Magnets are thick enough to hold Trim in place).
- h. With the Thermatronic Control System **Always** exchange the Batteries in both the Handset and Receiver, with the High Level Control Systems **Always** exchange the Batteries in the Battery Box see Section 2.
- i. With the Thermatronic Control System ensure it is operational with the Handset.

**ALWAYS CONDUCT A GAS SOUNDNESS CHECK AFTER SERVICING.**

**ALWAYS RESEAL THE PRESSURE TEST POINT AND CHECK THAT IT IS GAS TIGHT.** (This accounts for a lot of recalls.)

**ALWAYS CLEAN THE GLASS PANEL ENSURING IT'S FREE FROM FINGERPRINTS.** (This accounts for a lot of recalls.)

**IF THERE IS ANY DAMAGE FOUND ON THE GLASS PANEL IT MUST BE REPLACED BEFORE THE FIRE IS USED.**

## 21 - FAULT FINDING GUIDE, SYMPTOMS AND POSSIBLE CAUSES

**Important:** In instances where it is indicating that the main control system needs changing, (specifically the 3 Button High Level or Thermatronic Controls Systems), you should investigate returning the whole Burner Control System Assembly to Nu-Flame for Rectification as this could be the least cost option.

- a. Prior to any Servicing ensure that you have carried out the procedures in Section 20.1 General (Servicing).
- b. Check the supply pressure at the isolation elbow.
- c. **Important:** With the High Level and Thermatronic Systems always change the batteries before carrying out any Fault Finding.

### 21.1 - RESETTING THE THERMATRONIC HAND HELD RADIO FREQUENCY CONTROL SYSTEM

**Full Reset** - If a new handset is obtained the control system will need to learn the handset's unique code via a Full Reset. Also, if the fire is not working and the Basic Reset (described on page 8) has not worked a Full Reset can be carried out:

- a. Remove the Ash Pan Cover and locate the electronic Receiver Box.
- b. Locate the Reset Hole on the side of the Receiver and using a pen press and hold in the Reset button until you hear two beeps.
- c. The first beep is short and the second beep is long. After the second beep release the Reset Button.
- d. Now on the Handset, within the next 20 seconds press and hold the Small Flame Button until you hear two additional short beeps confirming the code is set in the Receiver.
- e. If you hear one long beep the Code as not been set so repeat the procedure.
- f. If the Handset still does not work check the wiring and or replace the Receiver and Handset .

## 21.2 - NO SPARK IGNITION

- a. Replace the batteries in the receiver and handset (The 2 & 3 Button High Level Systems have Receiver batteries only).
- b. Check there is no dust/debris shorting out the electrode or blocking gas from the pilot.
- c. Check the condition of the Ignition lead and ensure it is connected to both the ignition electrode and receiver. Check that the Ignition lead is not trapped and or shorting, replace if required. For the Manual System this will involve a new control. For the High Level and Thermatronic Systems a separate ignition lead is available.
- d. Check the condition of the Electrode, if it sparks intermittently it may be cracked, replace.
- e. Check that gas is flowing from the pilot during the ignition sequence. Clean or Replace as required.
- f. For the 3 Button High Level & Thermatronic Controls only, listen to the control to hear if the pilot gas solenoid is opening. Change the receiver, and the handset at the same time and/or gas control. Refer to Section 22 for Cable connections diagram.

## 21.3 - PILOT GOES OUT AFTER FIRST LIGHTING

- a. Check there is no debris blocking the flame to the thermocouple.
- b. Check there is nothing covering the terminal guard/flue on the outside.
- c. Check the thermocouple is in the correct position because although the fixing nut may seem tight and secure, the Thermocouple may have slipped down. Slacken the fixing nut, reposition then retighten. With the Thermatronic System check all connections in the Thermocouple circuit., from the valve, interrupter and wiring connections to the Receiver.
- d. If the Pilot Flame seems small the Injector may be slightly blocked, replace.
- e. For the 3 Button High Level Control and the Thermatronic R F Systems only, listen to the control to hear if the pilot gas solenoid is opening. Change the receiver, and High Level Switch or Handset, (which ever applies), at the same time and/or the gas control. Refer to Diagram for Cable connections in Section 22.
- f. Also see Section 21.5.
- g. Specific to new installations and by far the highest cause of this type of fault. Typically the pilot and main burner lights with the door open but goes out when the door is closed. Part or all of the cutting aid has been left in the flue after cutting.

## 21.4 - PILOT LIGHTS BUT MAIN BURNER DOES NOT LIGHT

- a. With All Control Systems listen to hear if gas is flowing into the main burner.
- b. Check there is no dust or debris blocking the flame from the pilot to the main burner.
- c. With the 2 Button High Level Control check that both Control Knobs are in the on position, fully turned anti clockwise. Also check 'e' before determining the action required.
- d. With the 3 Button High Level & Thermatronic System check if the main control knob on the control is turning to the high setting and listen to hear if the valve is opening. If not change the Handset & Switch (which ever applies) and at the same time the gas control.  
For removal of the 3 Button Switch refer to 'f' and also refer to the Diagram for Cable connections in Section 22.  
Also check 'g' (below) before considering replacing any parts. You should also consider the **Important** note in 21.1.
- e. With the 2 Button High Level Control it is possible for the Main Burner to light when first lit after lighting the Pilot but then the Push Buttons do not operate the control. Operate the bottom button and listen to see if the Control Knob turns. If it does not then change the batteries, if still a problem change the Switch Assembly as detailed in 'f'.
- f. For removal/replacement of the 2 & 3 Button Switches first remove the 2 screws retaining the Switch Shield, remove the 2 screws retaining the Switch Assembly. Disconnect the push on wire connections at the control. Remove the switch and wires and replace with a new component in reverse order.
- g. All Control Systems have a Pressure Test Point to allow the Burner Pressure to be checked to confirm if gas is flowing from the control. On the Manual Control it is visible at the front left of the control. On the High Level Controls it is on the left of the control and on the Thermatronic it is at the front of the Control and is the left/rear Pressure Test Point.
- h. Check if the main injector is blocked. Clean or Replace.
- i. Also see Section 21.3.g.

## 21.5 - PILOT FLAME SHORTENS, OR GOES OUT WHEN MAIN BURNER IS SELECTED

- a. Monitor the supply pressure at the isolation elbow as the main burner lights. If pressure drops significantly, check gas pipe sizing and quality of pipe bending. Check for debris in the gas supply and or gas filter if fitted.
- b. Check that another appliance is not affecting the gas supply pressure.
- c. Check the points raised in Sections 21.3 and 21.4.

## 21.6 - POOR FLAME PICTURE

- a. Check the supply pressure is correct at the isolation elbow. If the pressure is low, check gas pipe sizing, quality of pipe bending. Check for debris in the gas supply and or gas filter if fitted.
- b. All Control Systems have a pressure point to allow the Burner Pressure to be checked. On the Manual Control it is visible at the front left of the control.  
On the Thermatronic it is present at the Front, the left pressure tapping on the Control. On the High Level Control it is on the left of the Control, the rear pressure tapping. You may wish to check 'c' first.
- c. Check that another appliance is not affecting the gas supply pressure.
- d. Check that the Flue Terminal and Guard are not damaged or covered in any way.
- e. Check fuel bed layout as detailed in Section 16.
- f. Check that none of the fuel cutting aid as not been accidentally left in the flue.
- g. Check that the flue pipe as not be forced into the flue spigot too far, (over 40mm) and past its stop blocking off the flue flow.

## 21.7 - FIRE OPERATES FOR A WHILE THEN GOES OUT

- a. Check the supply pressure is correct at the isolation elbow with all other gas appliances working. If the pressure is low or fluctuating up and down check gas pipe sizing, quality of pipe bending. Check for debris in the gas supply, pilot pipe and or gas filter if fitted.
- b. Check the points raised in Sections 21.2 and 21.3.
- c. For the High Level Control check that the Control and Switch are functioning correctly as detailed in Section 2.2. and also specifically check the Thermocouple Electrical Connections and Pilot Flame size.

- d. For a Thermatronic System check that the Control is functioning correctly as detailed in Section 2.4 and also specifically check the Thermocouple Electrical Connections and Pilot Flame size.
- e. Check that the Flue Terminal and Guard are not damaged or covered in any way.
- f. Also see Section 21.3.g.
- g. See 21.6 g.

### **21.8 - THERMATRONIC RADIO FREQUENCY CONTROL SYSTEM DOES NOT OPERATE**

- a. Check the control is being correctly operated - see Section 2.4
- b. Check for error messages and check batteries - see Section 2.5
- c. Reset the Mertik Maxitrol Logic Circuits - see Section 2.6

### **21.9 - HIGH LEVEL 2 & 3 PUSH BUTTON CONTROL DO NOT OPERATE**

- a. Change the batteries then see if the push buttons now operate.
- b. The Switch and Receiver/Battery Box should be replaced.
- c. The Side Switch Buttons will feel quite warm during operation however overheating can be caused by a poorly sealed fire to the fire surround
- d. Over Heating of Side Switch Buttons caused by wrongly fitted glass door allowing heat to escape .
- e. Over heating of Side Switch Buttons caused by flue related issues see 21.6 f & g.

**Important :** In instances where it is indicating that the main control system needs changing, (specifically the 3 Button High Level or Thermatronic Control Systems), you should investigate returning the whole Burner Control Assembly to Nu-Flame for rectification as this could be the least cost option.

### **21.10 - FUMES EMITTING FROM THE FIRE**

It is quite normal for fumes to come from the fire when it is first used and we recommend the area is well ventilated.

- a. Check to ensure the Pressure Relief Door, at the top of the fire, is closed - see Section 15.
- b. Check that the Glass Panel is fitted securely and sealed.
- c. Sometimes fumes from the fire can be mistaken for odours that will naturally burn off the fire when it is first operated from new or during periods of little use and we recommend that the fire is run at maximum with doors/windows open to ventilate the room.  
**See Important Note in Section 18 under Testing, Commissioning & Use.**
- d. Fumes can be coming specifically from inferior Fire Surround materials e.g. resins from conglomerate materials which we do not recommend rather than natural surround materials.
- e. Fumes can also come from materials like the resins used with Fibre Glass if this type of product has been used.
- f. Typically odours come from the Fire Surround and the adhesives used therefore you should ensure that the Surround back Panel is sealed to the wall to reduce the temperatures the Fire Surround will be exposed to.

**IF THERE IS ANY DAMAGE FOUND ON THE GLASS PANEL IT MUST BE REPLACED BEFORE THE FIRE IS USED.**

**ALWAYS CONDUCT A GAS SOUNDNESS CHECK AFTER SERVICING.**

**ALWAYS RESEAL THE PRESSURE TEST POINT AND CHECK THAT IT IS GAS TIGHT.** (This accounts for a lot of recalls.)

**ALWAYS CLEAN THE GLASS PANEL ENSURING IT'S FREE FROM FINGERPRINTS.** (This accounts for a lot of recalls.)

**Note: Marks on the Glass Panel are Not Covered by the Manufacturers Warranty.**

**VITESSE BF (Natural Gas) Standard Remote Control**

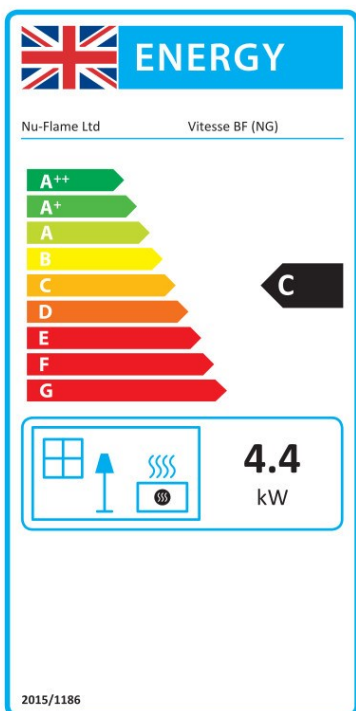

Supplier	Nu-Flame Limited
Model	Vitesse BF (NG)
Energy Efficiency Class	C
Direct Heat Output	4.4kW
Energy Efficiency Index	79.0
Useful Energy Efficiency at Maximum	90.0%
Useful Energy Efficiency at Minimum	75.0%

The fire must be Installed & serviced by a properly qualified (in accordance with Local & National Codes) Installation Engineer and in accordance with these Installation Instructions

**VITESSE BF (Natural Gas) Thermostatic Remote Control**

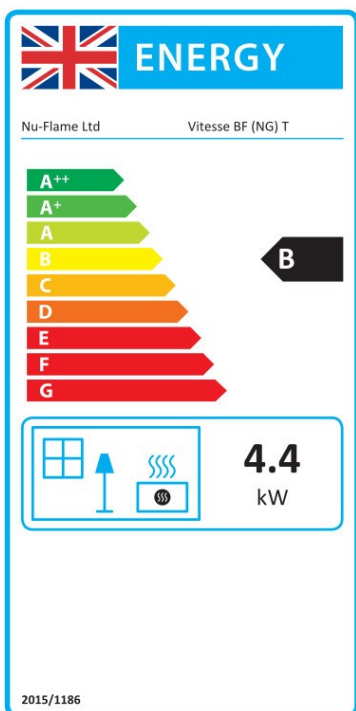

Supplier	Nu-Flame Limited
Model	Vitesse BF (NG)T
Energy Efficiency Class	B
Direct Heat Output	4.4kW
Energy Efficiency Index	84.0
Useful Energy Efficiency at Maximum	90.0%
Useful Energy Efficiency at Minimum	75.0%

The fire must be Installed & serviced by a properly qualified (in accordance with Local & National Codes) Installation Engineer and in accordance with these Installation Instructions



**VITESSE BF (Propane) Standard Remote Control**

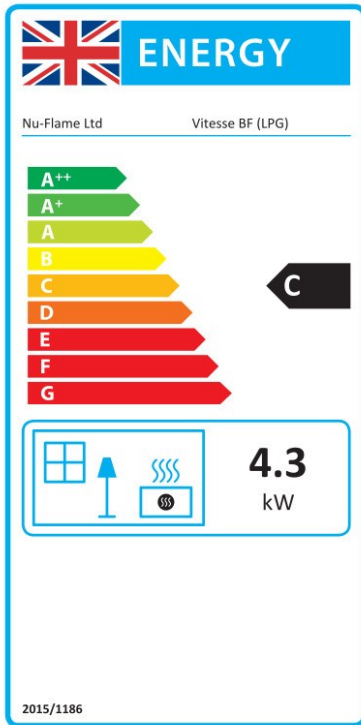

Supplier	Nu-Flame Limited
Model	Vitesse BF (LPG)
Energy Efficiency Class	C
Direct Heat Output	4.3kW
Energy Efficiency Index	78.4
Useful Energy Efficiency at Maximum	89.4%
Useful Energy Efficiency at Minimum	73.4%
<p>The fire must be Installed &amp; serviced by a properly qualified (in accordance with Local &amp; National Codes) Installation Engineer and in accordance with these Installation Instructions</p>	

**VITESSE BF (Propane) Thermostatic Remote Control**

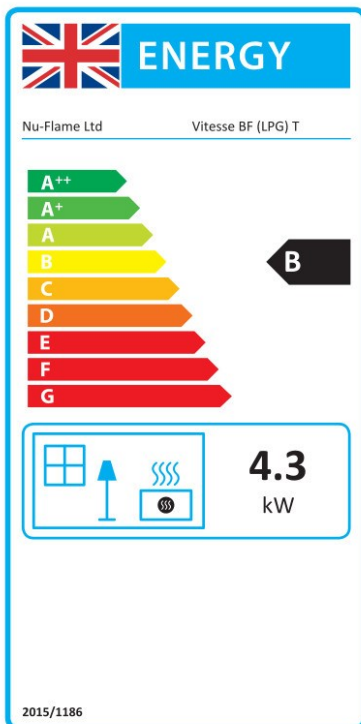

Supplier	Nu-Flame Limited
Model	Vitesse BF (LPG) T
Energy Efficiency Class	B
Direct Heat Output	4.3kW
Energy Efficiency Index	83.4
Useful Energy Efficiency at Maximum	89.4%
Useful Energy Efficiency at Minimum	73.4%
<p>The fire must be Installed &amp; serviced by a properly qualified (in accordance with Local &amp; National Codes) Installation Engineer and in accordance with these Installation Instructions</p>	

## 22c - ENERGY CLASS & PRODUCT FICHE (Natural Gas Models)

### VITESSE BF (Natural Gas) Standard Remote Control

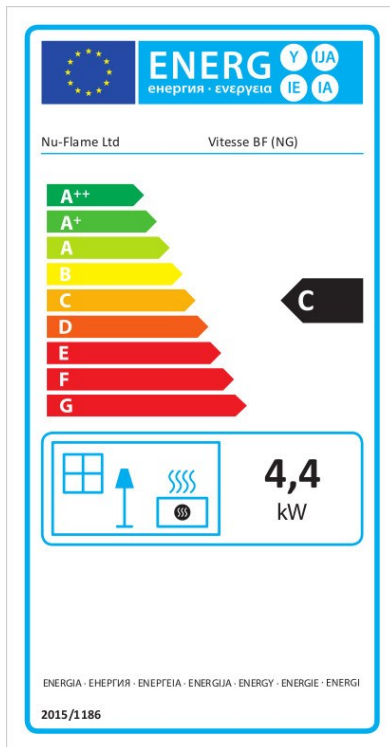

Supplier	Nu-Flame Limited
Model	Vitesse BF (NG)
Energy Efficiency Class	C
Direct Heat Output	4.4kW
Energy Efficiency Index	79.0
Useful Energy Efficiency at Maximum	90.0%
Useful Energy Efficiency at Minimum	75.0%
<p>The fire must be Installed &amp; serviced by a properly qualified (in accordance with Local &amp; National Codes) Installation Engineer and in accordance with these Installation Instructions</p>	

### VITESSE BF (Natural Gas) Thermostatic Remote Control

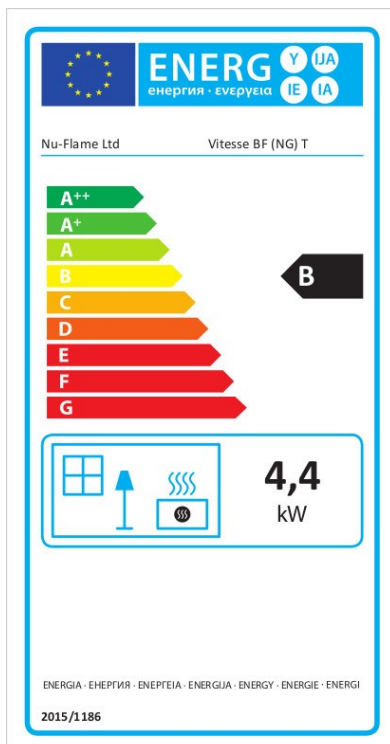

Supplier	Nu-Flame Limited
Model	Vitesse BF (NG)T
Energy Efficiency Class	B
Direct Heat Output	4.4kW
Energy Efficiency Index	84.0
Useful Energy Efficiency at Maximum	90.0%
Useful Energy Efficiency at Minimum	75.0%
<p>The fire must be Installed &amp; serviced by a properly qualified (in accordance with Local &amp; National Codes) Installation Engineer and in accordance with these Installation Instructions</p>	

## 22d - ENERGY CLASS & PRODUCT FICHE (Propane Models)

### VITESSE BF (Propane) Standard Remote Control

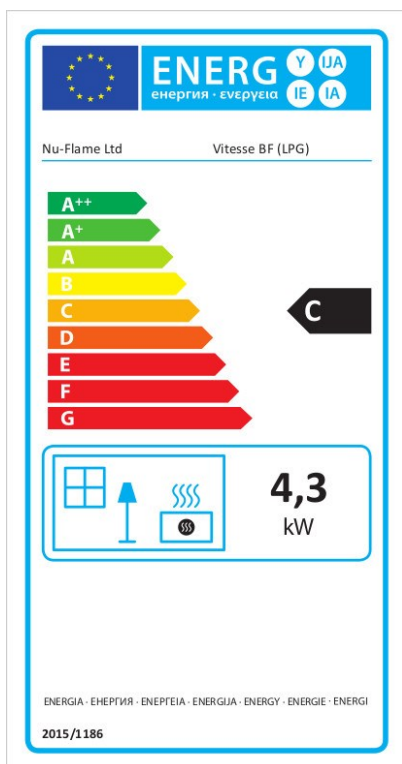

Supplier	Nu-Flame Limited
Model	Vitesse BF (LPG)
Energy Efficiency Class	C
Direct Heat Output	4.3kW
Energy Efficiency Index	78.4
Useful Energy Efficiency at Maximum	89.4%
Useful Energy Efficiency at Minimum	73.4%
<p>The fire must be Installed &amp; serviced by a properly qualified (in accordance with Local &amp; National Codes) Installation Engineer and in accordance with these Installation Instructions</p>	

### VITESSE BF (Propane) Thermostatic Remote Control

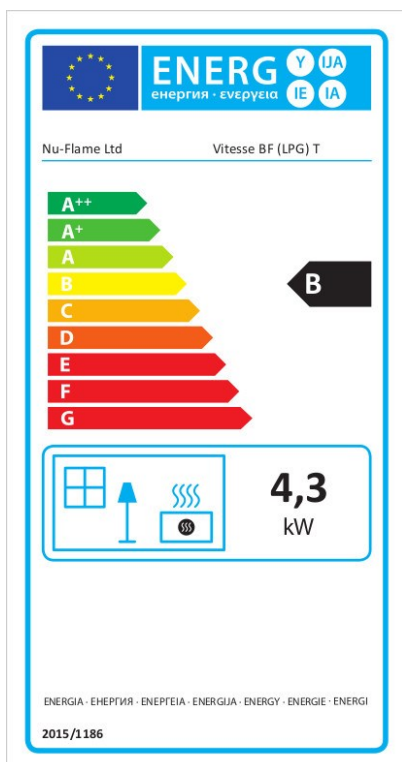

Supplier	Nu-Flame Limited
Model	Vitesse BF (LPG) T
Energy Efficiency Class	B
Direct Heat Output	4.3kW
Energy Efficiency Index	83.4
Useful Energy Efficiency at Maximum	89.4%
Useful Energy Efficiency at Minimum	73.4%
<p>The fire must be Installed &amp; serviced by a properly qualified (in accordance with Local &amp; National Codes) Installation Engineer and in accordance with these Installation Instructions</p>	

## UK Declaration of Conformity

**Name of the Client** : Nu-Flame Ltd  
Address of the Client : Unit 4  
: Kimpton Trade & Business Centre  
: Minden Road  
: Sutton  
: Surrey  
: SM3 9PF

Telephone : 020 8641 9992

Manufacturing Location : As above

**This declaration of conformity is issued under the sole responsibility of the manufacturer above for:**

Product : Vitesse BF

Certificate Number : UKCA 744504

**The object of the declaration described above is in conformity with relevant harmonized legislation**

Regulation 2016/426 on gas appliances as brought into UK law and amended.

The following harmonised standards and technical specification have been applied:

EN613: 2001 (Amd1). TP6.14 (V5) Independent gas-fired convection heaters

**Where the Essential Requirements of the GAR have been met and approved by Notified Body:**

Responsible Test House : BSI Group  
Address : Holywell Park  
: Ashby Road  
: Loughborough  
: LE11 3AQ  
: United Kingdom

Authorized Signature of Manufacturer:



Date of Issue: 19th April 2021

## EU Declaration of Conformity

**Name of the Client** : Nu-Flame Ltd  
Address of the Client : Unit 4  
: Kimpton Trade & Business Centre  
: Minden Road  
: Sutton  
: Surrey  
: SM3 9PF

Telephone : 020 8641 9992

Manufacturing Location : As above

**This declaration of conformity is issued under the sole responsibility of the manufacturer above for:**

Product : Vitesse BF  
Certificate Number : CE688456

**The object of the declaration described above is in conformity with relevant harmonized legislation**

Gas Appliance Regulation (EU) 2016/426

The following harmonised standards and technical specification have been applied:

EN613: 2001 (Amd1). TP6.14 (V5) Independent gas-fired convection heaters

**Where the Essential Requirements of the GAR have been met and approved by Notified Body:**

Responsible Test House : BSI Group  
Address : Holywell Park  
: Ashby Road  
: Loughborough  
: LE11 3AQ  
: United Kingdom

Authorized Signature of Manufacturer:



Date of Issue: 21<sup>st</sup> April 2018

24. - DIAGRAM OF RADIO FREQUENCY CONTROL SYSTEM

**MERTIK MAXITROL**

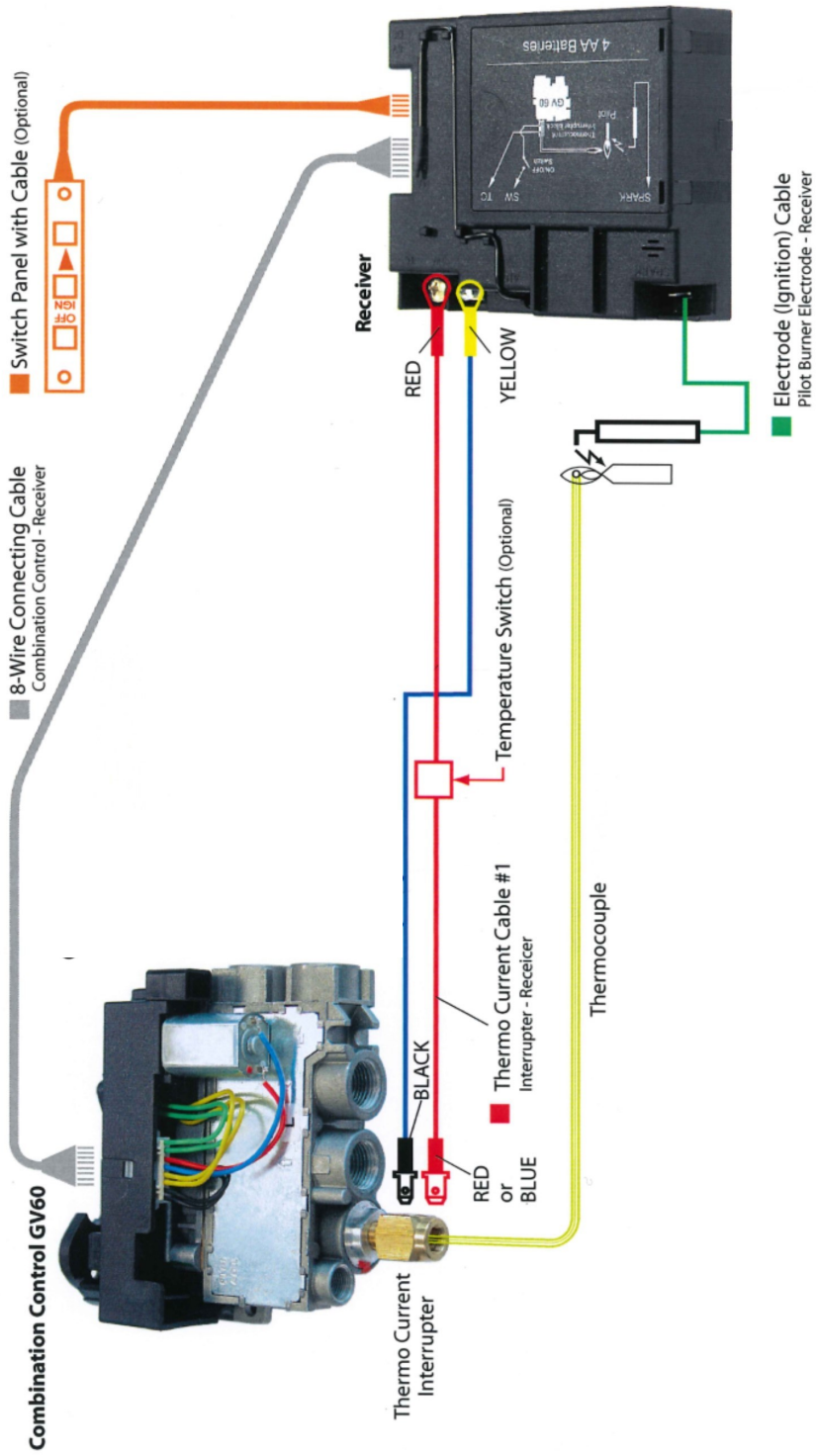



**Telephone 020 8254 6802**

#### **Nu-Flame Warranty and Repair Procedure for The Vitesse B.F.**

Nu-Flame fires are guaranteed for 1 year from the date of purchase. During that time our guarantee is to repair at our option, or replace at no charge a fire that proves to have faulty components or workmanship.

**Telephone Help Line.** In the event of a problem with a fire the first course of action should be to telephone our technical department on 020 8254 6802 during normal working hours 9 - 5.30 Monday - Friday (closed 1 - 1.30). If appropriate this should be done before the installer leaves site as we may well be able to resolve the problem over the phone and in any event it may well save the installer a return visit to site. If we are not able to resolve the problem over the phone we may ask you to return the fire, and will log your details and give you a return reference number.

**Returning the Fire and parts thereof.** After assessment we might consider it best to return part of the appliance, such as the burner only, for testing. In this example the burner can then be thoroughly inspected and any signs of installation faults can be reported back to you. After any repair work is carried out the flow rates can be checked and re-set if necessary in order to fully comply with CE approval. **Note:** It is a condition of the warranty that you do not return any parts to us unless we request you to do so. For example if we request that the burner only is returned and you send the entire appliance the glass and the fuel bed and other items could be damaged during the return delivery to us. We will not be liable for any such breakages.

Under no circumstances should any attempt be made to repair the burner on site without our express knowledge and approval during the warranty period.

This guarantee is given subject to the following provisions:

1. That the installation is carried out by a Registered Installer (we may require their registration details).
2. That the appliance is installed and used in accordance with our Installation & User instructions.
3. That the gas supply pressure at the appliance is not more than 3mbar below the gas pressure stated on the data plate when the appliance is running on high flame, with any other major gas appliances also running.
4. That the fireplace and flue system conform to relevant local codes, building regulations and British Standards.
5. This Guarantee is not transferable and relates to the original installation only.
6. The appliance has not been subject to misuse or accident or been modified or repaired by any person other than the authorised employee or authorised representative of Nu-Flame Ltd.
7. The Record Data Section on the front of the Installation & Servicing Instructions is to be completed on installation.
8. Nu-Flame Ltd accepts no liability for any consequential loss or damage arising from the use or failure of the product or any information provided, including, but not limited to, economic or financial loss, damage to peripheral equipment or products, loss of use, productivity or time.
9. That the serial no. data plate on the burner is intact.

This guarantee in no way reduces your statutory rights.

This guarantee supersedes any previously published guarantees.

#### **Chargeable Repairs During And After The Warranty Period**

If a repair is chargeable during the warranty period, due to installation faults we will inform you and where possible give you a quote, or if this is not possible, a price guide before starting work. We cannot always give a firm cost until we commence the repair as it is not always possible to tell which components have been damaged.