



VITESSE CF

INSET CONVECTION HEATER SUITABLE FOR NATURAL GAS & PROPANE

USE, INSTALLATION & SERVICING INSTRUCTIONS

Important

**A Carbon Monoxide Alarm Complying With BS EN 50201 Must Be Provided
In The Room Where The Gas Fire Is Installed.**

It Must Be Fitted And Maintained In Line With The Manufacturer's Instructions.

All Propane (LPG) Installations Should Be Fitted with a Over Pressure Shut Off Valve (OPSO).

The glass panel and outer parts of this fire will become hot during use, cloths or combustible items must not be placed close to or on the fire. We recommend that a Fireguard conforming to BS8423 should be used for protection of Young Children the Elderly, Infirm and Pets.

ALL INSTRUCTIONS MUST BE LEFT WITH THE USER FOR SAFE KEEPING

MANUFACTURED by:

Nu-Flame Limited

**Unit 4, Kimpton Trade & Business Centre
Minden Road, Sutton, Surrey SM3 9PF**

Tel: 020 8254 6802

Fax: 020 8641 9992

Email: sales@nu-flame.co.uk

Country of Destination – GB & IE

CONTENTS

Section No	Subject	Page
User Section		
-	Contents Page	2
-	Box Contents	2
-	Fitting Kit Contents	3
1	Important Notes	4
2	Lighting & Controlling the Fire	5
3	Cleaning the Fire	7
4	Servicing	7
Installation Section		
-	Record Data	7
-	Site Surveying	8
5	Installation Requirements	9
6	Appliance Data	9
7a	Appliance Dimensions	9
7b	Trim & Fume Dimensions	10
8	Flue Requirements	11
9	Ventilation	11
10	Gas Supply	11
<i>Sections 11 - 14 are for the various installation applications - Ensure you refer to the section relevant to your requirement</i>		
11	Class 1 & Lined Flue Fire Surround Application Fireplace Construction	12
12	Pre-Cast Fireplace Application - Fireplace Construction (Rebated or Purpose Built Fire Surround & Construction)	14
13	BS715 Shallow Flue Box with 5" Twin Wall Flue Application (Fireplace or Hole in the Wall Construction)	16
14	Hole in the Wall Application into Class 1 & Lined Flue Builders Opening Construction	18
15	Fixing the Fire	19
16	Arrangement of the Fuel Effect	21
17	Fitting the Burner Heat Shield	23
18	Testing, Commissioning & Use	24
19	Briefing the Customer	25
20	Servicing	25
21	Fault Finding Guide, Symptoms & Possible Cause	26
22a&b	Energy Class & Product Fiche	28
23a&b	UK & EU Declaration of Conformity	30
24	Diagram of Thermatronic Radio Frequency Control System	32
-	Guarantee	33

BOX CONTENTS

The Fire comes in 1 box containing the Fire with chosen Control and Fixing Kit (see next page for fixing kit contents) plus the Fuel Bed Components, (Matrix & Coals).

Trims & Frames and or Frets will be supplied separately with fixing Instructions where applicable.

IMPORTANT : THE VITESSE CF CAN ONLY BE USED WITH NU-FLAME'S CE APPROVED FRETTS & FENDERS

VITESSE CF FITTING KIT CONTENTS:

Cable Fixing Kit (2 # cables and fittings, 4 # eye screws, 4 # plastic plugs)

1 # Flue Restrictor

2 # No6 x 10mm pointed self tapping screws for above

2 # No8 x 10mm blunt self tapping screws for fixing Burner Heat Shield

2 # No6 x 5mm blunt self tapping screws for fixing the stainless steel Top Louvre / Heat Shield. The Top Louvre / Heat Shield is only supplied with Flat Trims - it is not required if using a Curved Trim

4 # Magnets for holding Front Trim on

1 # 10mm Back Nut & olive to connect 8mm copper pipe gas supply to the burner (via the isolation elbow)

1 # 2.1 metre length of 6mm x 4mm self adhesive silicone sealing strip.

1 # No2 Posidriv screwdriver (for glass removal)

1 # Set of Instructions / Warranty

Note – No6 screws are a smaller diameter than No8 screws.

THE VITESSE CF USER INSTRUCTIONS

1. - IMPORTANT NOTES

- a. This appliance must be installed by a properly qualified (in accordance with National & Local Regulations) Installation Engineer.
- b. The connection of this appliance and ventilation requirements (if any) are to be according to National & Local Codes.
- c. This appliance does not normally require any purpose provided additional ventilation, however if it has been found necessary to add a vent periodically check that it is free from obstruction.
- d. Consult all Instructions before Installation and Use.
- e. Do not throw rubbish on, or attempt to burn any materials on this appliance. Any Debris or Foreign Matter must be removed from the fire.
- f. Under No Circumstances must this fire be used if the Glass Panel is broken, damaged, cracked or has been removed.
- g. The glass panel and outer parts of this fire will become hot during use, cloths or combustible items must not be placed close to or on the fire. We recommend that a Fireguard conforming to BS8423 should be used for protection of Young Children the Elderly, Infirm and Pets.
- h. The appliance should be Serviced Annually in accordance with the Gas Safety & Uses Regulations.
- i. Where the flue has been used for Solid Fuel it must be swept before Installation.
- j. If at any time you smell gas or fumes turn the fire off and contact your Installer.
- k. These Instructions must be left with the User for future reference.
- l. During its first period of use any protective coatings and oils will burn out of the appliance and it is wise to ventilate the room for the first hour of use.
- m. This appliance is fitted with an oxygen depletion sensing system, which automatically shuts off the gas supply to the fire if the oxygen level in the room is depleted, due to lack of primary air, or obstructed flue (blocked chimney) that would lead to incomplete combustion of the gas. It must not be tampered with and only replaced with a genuine Nu-Flame ODS.
- n. In the event that the fire shuts down for any reason, attempt to restart it. If there is a continuing problem, call in a properly qualified specialist engineer.
- o. There are no user replaceable parts in the appliance apart from the batteries, if a High Level or Thermatronic Electronic Control System was ordered.
- p. The chimney should be regularly checked to ensure that all the products of combustion are entering the flue & that there is no build up of soot. If there is, the appliance must be serviced.
- q. Coal are manufactured from RCF (Refractory Ceramic Fibre are supplied with this appliance, see Health & Safety guidance. Do not use real coals as this is dangerous. If the simulated fuel bed components need renewing please obtain suitable replacements from a Nu-Flame Stockist.
- r. The fire must be installed in accordance with the rules in force and these Instructions it must be installed into a fireplace or builders opening as detailed in these Instructions.
- s. No combustible materials e.g. curtains must be closer than 500mm to the fire.
- t. For Fire Surround Applications a 150mm (6") combustible shelf can be fitted above the fire provided it is 195mm above the Fireplace Opening.
- u. The Fire can be installed into a suitably designed fire surround with a 150°C Rating.
- v. Explain to the customer that over time some wall staining will occur above the fire and this is due primarily to particles of dust present in the hot convection air circulating up and over the fire/surround and sticking to the wall.

! IMPORTANT NOTE ! THE GLASS PANEL ON THIS FIRE WILL BECOME VERY HOT DURING OPERATION - SEE ITEM 'g.' ABOVE.

It is quite normal for the fire to make popping and burbling sounds when in use, as would a solid fuel fire.

Health & Safety Advice Refractory Ceramic Fibre (RCF)

Advice when working with Fuel Bed Components including Installing, Servicing and Disposal.

The Fuel Effect parts and possible Linings of this fire are made from Refractory Ceramic Fibre (R.C.F.) a Class 2 Carcinogen which is a material designed for this Application. Excessive exposure to these types of materials may cause temporary irritation to eyes, skin and respiratory tract. Therefore take care when handling these articles to ensure dust is kept to a minimum.

It is not necessary to wear protective clothing when handling these articles but we do recommend you follow the normal hygiene rules of not smoking, eating or drinking in the work area, and always wash your hands before eating or drinking.

To minimise the release of RCF fibres during installation and servicing a HEPA filtered vacuum is recommended to remove any dust accumulated in and around the fire both before and after working on it.

When Servicing and if replacing these parts we do not recommend they are broken up but are sealed within a heavy duty polythene Bag and labelled as "RCF waste". This is not classified as "hazardous waste" and may be disposed of at a local licensed landfill site.

2. - LIGHTING & CONTROLLING THE FIRE

General

The fire is available with 4 Control Options: a Manual Control (Fire is lit and adjusted manually), a side Trim fitted 2 Button High Level Control (Fire when lit can be controlled with the Push Buttons), a side Trim fitted 3 Button High Level Control (Fire can be lit and controlled with the Push Buttons) or Thematronic Radio Frequency Electronic Control System (Fire is lit & operated with a Handset).

2.1 - LIGHTING & CONTROLLING THE FIRE - MANUAL CONTROL

Remove the Ash Pan to get access to the Control Knob used to operate the Fire.

a. Switching On/Ignition. Depress the control knob & turn counter clockwise. Gas will flow to the Pilot Burner (Pilot Burner is visible looking down through the glass at the left side), the Piezo Igniter will give off first one, then, as you turn, a second high voltage spark & the Pilot Burner will Light. (More than one attempt may have to be made on first lighting.) Keep the Control Knob depressed for approximately 10 seconds to heat up the Thermocouple. Turn the Control Knob fully counter clockwise to release gas to the Main Burner.

b. Control of Gas Flow. Turning the Control Knob clockwise reduces the gas flow from Maximum to the Pre-Set Minimum Setting. Turning between Maximum & Minimum does not actuate the Piezo Igniter. The Control Valve can only be set on the Pilot by depressing the control knob & turning it to the pre-selected pilot position.

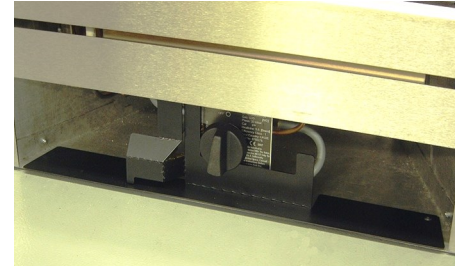
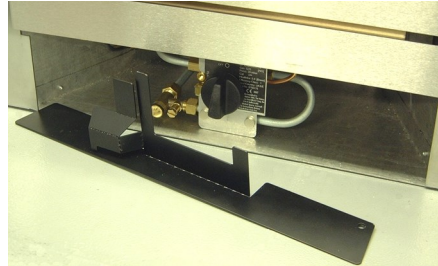

c. Switching Off. Press the Control Knob in at the Pilot Position & turn Clockwise to Off.

Note - For manually controlled fires a black cover plate is supplied to cover some of the pipe work and associated fittings under the burner tray. This is freestanding and is for cosmetic purposes only; it need not be used if preferred. The controls can be operated with the cover in place (see photos on previous page).

2.2 - LIGHTING & CONTROLLING THE FIRE - 2 BUTTON HIGH LEVEL CONTROL

Requires Pilot Ignition First.

The side trim positioned High Level Control System is a battery operated gas fire control system that uses push buttons linked to a main control at the base of the fire. This control system is used with an oxy-pilot and has all the safety features required by law and CE approval.

Once the fire is lit by operating the Control behind the Ash Pan Cover the settings can be controlled by the 2 Push Buttons on the upper right side of the Trim.

Using the System

Remove the Ash Pan Cover to get access to the Control Knob used to operate the Fire.

a. Switching On/Ignition. Depress the right control knob & turn counter clockwise. Gas will flow to the Pilot Burner (Pilot Burner is visible looking through the fender, under the flue bed, at the front right hand corner), the integral Piezo Igniter will also give off a high voltage spark & the Pilot Burner will Light. (More than one attempt may have to be made on first lighting.)

Keep the Control Knob depressed for approximately 10 seconds to heat up the Thermocouple.

Turn the Control Knob fully counter clockwise to release gas to the Main Burner.

b. Control of Gas Flow Using the Side Trim Push Buttons. Press the lowest button to gradually reduce the gas flow from Maximum to the Pre-Set Minimum Setting, you will hear the motor turning the control. Keeping the Lower Button depressed will eventually turn the main burner off leaving the pilot alight.

To relight the main burner or increase the heat setting from low, press the Upper Button to achieve settings between low and high. When the fire has reached high the control under the fire will click repeatedly, release the button.

c. Switching Off. Remove the Ash Pan Cover and turn the right Control Knob Clockwise to Off.

d. Battery Replacement . The Batteries should be replaced every season, you will notice they need changing as gradually the Push Buttons cease to operate the Control.

e. Changing the Batteries. Remove the Ash Pan Cover and you will find the Battery Box on the right hand side.

Pull towards the front taking care not to strain the connecting wire. Using a small screw driver remove the screw, slide off the cover and take out the Batteries. Replace with 4 x AA good quality alkaline batteries, operate the Push Buttons to check the Batteries are fitted correctly.

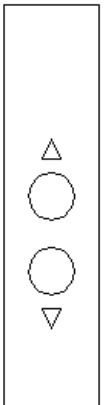

Note: Only Change The Batteries When The Fire Is Cold

2.3 - LIGHTING & CONTROLLING THE FIRE - 3 BUTTON HIGH LEVEL CONTROL

The 3 Button High Level Control Lights the Pilot and Controls the Fire.

The side trim positioned High Level Control System is a battery operated gas fire control system that uses push buttons linked to a main control at the base of the fire. This control system is used with an oxypilot and has all the safety features required by law and CE approval.

Note: The Centre Button is both the Ignition and Off Button.

Using the System

- a. **Ignition.** Simultaneously press and hold the Centre Button until a short acoustic signal confirms that the sequence has begun, then release the buttons. Continuous audible signals confirm that ignition is in progress.
When pilot ignition is confirmed the motor will open the valve to maximum flame height – this takes about 30 seconds.
When the fire is first operated and on occasions when the fire has not been used for some time the Pilot may not light after pressing the Centre Ignition Button even though the acoustic sound may have been heard. On these occasions it may be necessary to repeat the sequence a number of times to light the pilot. This is quite normal.
- b. **Flame Height Adjustment.** Press the bottom down arrow button until the flame height is at the desired position.
If you try to go beyond the preset low flame minimum height the fire will turn off leaving the pilot burner alight (This is the standby position). You will learn from experience the minimum preset flame height.
- c. **Relighting the Fire.** To relight the fire from the standby position, or to increase the flame height from low flame, press the top up arrow.
Please note that you can have the flame height anywhere between maximum and preset low.
For fine adjustment simply tap the up or down arrows.
- d. **Switching Off.** Press the centre button.
- e. **Battery Replacement.** The Batteries should be replaced every season, you will notice they need changing as gradually the Push Buttons cease to operate the Control.
- f. **Changing the Receiver Batteries.** To change the Receiver Batteries remove the Ash Pan Cover and locate the electronic receiver box, underneath the fire on the right hand side. Pull towards the front taking care not to strain the connecting wire. Slide open the plastic cover to gain access to the battery compartment. Replace with 4 x AA good quality alkaline batteries, operate the Push Buttons to check the Batteries are fitted correctly. Remember to put it back in the same position.

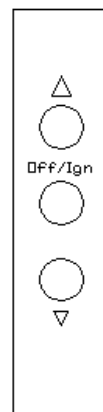

2.4 - LIGHTING & CONTROLLING THE FIRE – THERMATRONIC HAND HELD RADIO FREQUENCY CONTROL

The Thermatronic Control System is a battery operated gas fire control system that uses a microprocessor to provide the working sequences needed by the fire, and when used with an oxypilot has all the safety features required by law and CE approval.

Commands are accepted by the microprocessor when buttons are pressed. An audible beep means that the command is received, and the push button should immediately be released.

Using the System

Control can only be achieved if the Handset is pointed at the Fire. The red light will flash each time you press a button on the Handset.

- a. **Ignition.** Simultaneously press and hold the red button and the right upper button (linked by line) until a short acoustic signal confirms that the sequence has begun, then release the buttons. Continuous audible signals confirm that ignition is in progress. When pilot ignition is confirmed the motor will open the valve to maximum flame height – this takes about 30 seconds.
It is normal for condensation to appear on the glass on start-up. This will clear after a minute or so.
- b. **Flame Height Adjustment.** Press the small flame button until the flame height is at the desired position. If you try to go beyond the preset low flame minimum height the fire will turn off leaving the pilot burner alight (this is the standby position). You will learn from experience the minimum preset flame height.
- c. **Relighting the Fire.** To relight the fire from the standby position, or to increase the flame height from low flame, simultaneously press and hold the large flame button until the desired flame height is achieved.
Please note that you can have the flame height anywhere between maximum and preset low.
For fine adjustment simply tap the small or large flame buttons.
- d. **Switching Off.** Press the red/off button on the handset.



2.5 - GENERAL

- a. Battery replacement is recommended at the beginning of each heating season, or when an acoustic error message sounds during ignition.
- b. Error Message – Long signals (0.8 second tone – 0.2 second break) during ignition – probable cause batteries in electronic receiver box are nearly discharged.
- c. Error Message – 5 second continuous tone – probable cause – cable disconnected or on/off switch on valve is in off position.
- d. Batteries - Electronic Receiver Box - 4 x AA good quality alkaline - Handset - 1 x PP3 good quality alkaline.
- e. To change the Handset battery slide open the plastic panel on the back of the Handset.
- f. To change the Receiver Batteries remove the Ash Pan Cover and locate the electronic receiver box, underneath the fire on the right hand side. Pull towards the front taking care not to strain the connecting wire. Slide open the plastic cover to gain access to the batteries.
Remember to put it back in the same position under the metal shield.

Note: Only Change The Batteries When The Fire Is Cold

2.6 - RESETTING THE MERTIK MAXITROL LOGIC CIRCUITS

ONLY APPLIES TO THE THERMATRONIC HAND HELD RADIO FREQUENCY CONTROL

Basic Reset - It sometimes happens that (such as when the handset buttons are pressed out of sequence) the fire stops working because the logic circuits get confused and need to be reset.

To do this, simply remove the 4 x AA batteries from the Receiver Box (see section 2.5f above), wait for 1 minute and then refit the batteries. Wait for another minute and then point the handset at the fire and press the red/off button. Wait for another minute and then start the fire as normal. If the fire does not start repeat the resetting procedure. If the fire still does not work a Full Reset can be tried (see page 6).

Full Reset - If you obtain a new handset the control system will need to learn the handset's unique code via a Full Reset. Also, if the fire is not working and the Basic Reset (described on page 5) has not worked a Full Reset can be carried out:

Remove the Ash Pan Cover and locate the electronic Receiver Box.

Locate the Reset Hole on the side of the Receiver and using a pen press and hold in the Reset button until you hear two beeps. The first beep is short and the second beep is long. After the second beep release the Reset Button.

Now on the Handset, within the next 20 seconds press and hold the Small Flame Button until you hear two additional short beeps confirming the code is set in the Receiver.

If you hear one long beep the Code as not been set so repeat the procedure.

If after carrying out the above procedure the situation is not corrected it will be necessary to contact your Installer.

Note: For the Installation/Service Engineer - Resetting of the Handset & Control System is also covered in Section 21.1 page 22.

3. - CLEANING THE FIRE

Note: Marks on the Glass Panel are Not Covered by the Manufactures Warranty.

- a. **Important** : Always Allow the fire to cool before carrying out any cleaning.
- b. **Please Note:** The glass panel surface within the room will be marked by air borne particles as air circulates through the fire from the room, this is quite normal and cannot be prevented.
So the glass surface within the room can be cleaned with proprietary glass cleaners and any residue removed and dried afterwards.
No Abrasive Cleaners Must be used.
- c. Within the fire it is quite normal for soot and stains to build-up on the inside of the glass panel, this is why we advise that the glass panel must be fully cleaned during the Annual Service, however you can remove the glass panel for cleaning as follows:
 - i. Remove the Ash Pan. Remove the Outer Frame Assembly, it is held in place with magnets quite tightly, Pull to Remove.
 - ii. Using the Screw Driver provided Slacken the 2 Screws at the Bottom Left and Right Corners Securing the Glass Panel, Swivel the Brackets Off the Glass Panel then Ease it outward slightly at the base then Pull down and remove.
 - iii. To clean the glass panel use proprietary glass cleaners, however for stubborn stains use 'T Cut Original' and following treatment remove all residue and polish with a dry cloth. Take care not to damage the door seal and reposition around the glass if necessary.
Note: The glass is etched with the Nu-Flame logo ensure it is at the bottom right hand corner when refitting the glass panel.
- d. The outer surfaces of the fire can be cleaned with a damp cloth, do **not** use any abrasive cleaners.
For Stainless Steel finishes we recommend a small amount of Baby Oil.

! IMPORTANT ! The Fire **Must Never** be used without the Glass Panel in place or if the Glass Panel is in any way damaged.

4. - SERVICING

- a. The fire should be Serviced Annually in accordance with the Gas Safety & Uses Regulations.
- b. This fire contains no User Serviceable Parts apart from the batteries which are only used with the Thermatronic Control System option.
- c. Servicing must be carried out by a Registered Installer.
- d. For Servicing or Spare Parts contact your Installer quoting the Fire Name, Model and Serial Number, which can be found on the Data Badge. To find the Data Badge/Plate; with the fire cool remove the Ash Pan, the Data Badge can be found at the base next to the Control Knob.
- e. In the event that the fire shuts down due to any reason, attempt to restart it. If there is a continuing problem, call in a properly qualified specialist engineer.
- f. **Under No Circumstances** must this fire be used without the Glass Panel or if it is broken damaged or cracked.
- g. The Matrix in the fire is a Moulded Ceramic Fibre component incorporating Silicone Binders and you may notice that it develops cracks during operation. This is natural shrinkage caused by exposure to high temperatures and is quite normal for the material and will in no way affect the operation of the fire.

VITESSE CF INSTALLATION & SERVICING INSTRUCTIONS

RECORD DATA TO BE COMPLETED & KEPT BY USER:

IMPORTANT : THE VITESSE CF CAN ONLY BE USED WITH NU-FLAME'S CE APPROVED FRETS & FENDERS

PLACE OF PURCHASE DATE

ADDRESS & TEL. NO.

.....

.....

APPLIANCE SERIAL NO.

INSTALLED BY GAS SAFE REG. NO.

SITE SURVEYING - SURVEYING THE PROPERTY PRIOR TO INSTALLATION

THE FOLLOWING ARE RECOMMENDATIONS FOR SURVEYING AND ARE IN ADDITION TO THE REQUIREMENTS OF THESE INSTRUCTIONS, NATIONAL STANDARDS AND BUILDING REGULATION REQUIREMENTS.

The following recommendations should be considered to try to avoid problems that will result in issues after the fire has been fitted.

- a) Downdraught can be a major problem which may result in return visits with problems after the fire has been fitted so:
 - i) Check the geographical position of the property taking account of any known downdraught issues in the area.
 - ii) Check any existing Properties for any special chimney terminals that would indicate downdraught problems.
 - iii) Check any existing fires for signs of downdraught, e.g. discolouration above the fire.
 - iv) Ask the Customer if they ever suffer from wind blowing down the chimney.
- b) With Pre-cast flues check the following:
 - i) Any signs of walls over heated both on adjoining walls and upstairs. Bring any issues found to the attention of the Customer.
 - ii) Check for any Cracks in the wall above the fire.
 - ii) Check the soundness of any connecting tubes in the loft area.
- c) Take account of the type, size and height of the chimney when considering the suitability of the fire being considered.
For instance if the chimney is quite large or high a higher efficient fire may be more suitable or flue lining may need considering.
- d) Take account of the fire previously fitted and if the heat output will be sufficient for the room size and heat requirements of the room.
- e) Check the condition and soundness of the chimney before proceeding with the installation or any building work.
- f) Check any wall decoration around the fire for its suitability for withstanding temperatures especially with high efficient fires.
- g) Take account of the size of the room any large windows ensuring that the fire being considered will provide sufficient heat.
Make the Customer aware if you feel this could be an issue.
- h) Check if the suitability of the Control being considered will meet the Customers requirements, specifically with people with arthritic problems. Consider if a High level or Remote Control System would be more suitable and make the Customer aware of the advantages.
- i) If an high efficient fire is being considered into an existing fire surround determine if it is a suitable material, for example some micro marble surrounds are prone to discolouration. Check for any signs of discolouration and make the Customer aware of the possible problem. You may wish to advise that a more suitable Fire Surround be considered.
- j) Carry out a gas soundness check on the current installation prior to Installation.

We would recommend that if you come across known problems in your area that you add them to the above survey points.

If you are unsure of any aspect of the Installation seek expert advice.

5. - INSTALLATION REQUIREMENTS

THIS APPLIANCE MUST BE INSTALLED AND SERVICED BY A PROPERLY QUALIFIED, (IN ACCORDANCE WITH LOCAL & NATIONAL CODES), INSTALLATION ENGINEER.

It is the Law in the UK that All gas appliances are installed by a competent person in accordance with the GAS SAFETY (INSTALLATION AND USE) REGULATIONS 1998 (As amended), the relevant British Standards for Installation work, Building Regulations, Codes of Practice and these Instructions. In the UK a Registered Installer is deemed competent. In the Republic of Ireland, all Irish Standards, Local Codes and Bord Gais recommendations should be adhered to. The Installation should also be carried out in accordance with the following where relevant:

1. BS5871 Part 2
2. BS5440 Parts 1 & 2
3. BS6461 Parts 1 & 2
4. BS6891
5. BS8303

Building Regulations and Standards issued as relevant by the Department of the Environment or the Scottish Development Department.

In the Republic of Ireland Installation should be carried out in accordance with IS813, ICP3, IS327, Building Regulations, Codes of Practice, these Manufacturers Instructions and any Rules In Force.

Particular Reference should be made to the Ventilation Requirements, for the UK this Appliance would not normally require any additional purpose provided ventilation, for the Republic of Ireland ventilation should be in accordance with IS813 Domestic Gas Installations.

Failure to comply with the above could leave the Installer Liable to Prosecution and Invalidate the Warranty.

IMPORTANT

BEFORE PROCEEDING WITH THE INSTALLATION READ THESE INSTRUCTIONS CAREFULLY. THESE INSTRUCTIONS SHOULD BE LEFT WITH THE USER FOR SAFE KEEPING AND FUTURE SERVICING. PRIOR TO INSTALLATION ENSURE THAT THE GAS TYPE AND PRESSURE ARE AS STATED ON THE APPLIANCE DATA BADGE.

6. - APPLIANCE DATA

- a. Gas Type: See Data Plate, (Natural Gas at 20mbar or Propane at 37mbar).
- b. Burner Pressure: Natural Gas 18.7mbar cold Propane 36.3mbar cold
- c. Control System: Manual or Thermatronic (Fully Sequential) Control System operated by Handset pointed at Receiver.
- d. Fire Safety: Oxygen Depletion & Flame Failure Device.
- e. Ignition: Manual-Integral Piezo Igniter, Thermatronic-Full Sequential Control.
- f. Inlet Connection: 8mm Compression Fitting to Gas Isolation Elbow.
- g. Category: I2H, I3P.
- h. Injector: Natural Gas (G20) -360 Multi hole. Propane (G31) - 180 Single hole.
- i. Heat Input: High: Natural Gas (G20) - 5.6kW Gross (5.04kW Nett) Propane (G31) - 5.25kW Gross (4.83kW Nett)
- j. Heat Input: Low: Natural Gas (G20) - 2.0kW Gross (1.8kW Nett) Propane (G31) - 2.0kW Gross (1.84kW Nett)
- k. Efficiency Class: 1. The Efficiency of this appliance has been measured as specified in BS7977-1:2009 + A1 2013 and the results obtained were Natural Gas 79.3% gross (88% Nett) and Propane 79.5% gross (86.4% Nett). The test data has been certified by BSI Group (0086) and can be used in the UK Government's Standard Assessment Procedure (SAP) for Energy Rating of Dwellings.
- l. Heat Output: High: Natural Gas (G20) - 4.44kW Propane (G31) - 4.17kW
- m. Heat Output: Low: Natural Gas (G20) - 1.3kW Propane (G31) - 1.3kW
- n. Pilot ODS Type: Natural Gas (G20) - P448D 0608. Propane (G31) - P477 0906.
- o. Nitrous Oxide (NOx) - 130mg/kWh.

7a. - APPLIANCE DIMENSIONS

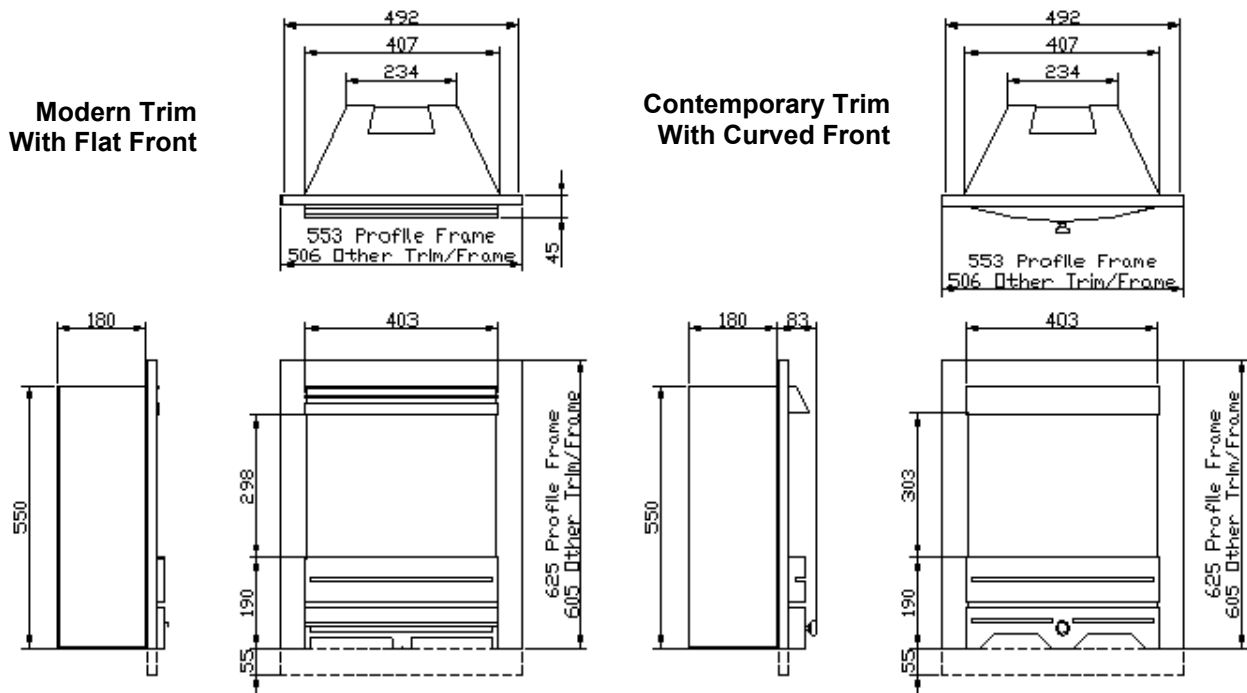

Solid lines denote 3 sided frame for fireplace use. Additional detail for "Hole in the Wall" frames is shown by dotted lines.

Designs may vary; the diagram above is to show important dimensions only.

7b. - TRIM & FRAME DIMENSIONS (Other Optional Trim & Wall Frame Styles)

Note: The following Trim & Frames are supplied separately with their own Instructions and fixings screws/brackets as required.

The Arc Trim

The Arc Trim is supplied with fixing brackets.

The Arc Trim (Fireplace Version) can be installed with or without the Arc Frame (Fireplace Version).

The Arc Trim (Hole in Wall Version) is for Wall Mounted fire applications and can be used with or without the Arc Wall Frame (Hole in the Wall Version).

Also See Flat Area Requirements For Each Trim and Frame Type

Arc Wall Frame (Hole in Wall Version)
Minimum Flat Area = 695mm(h) by 740mm(w)

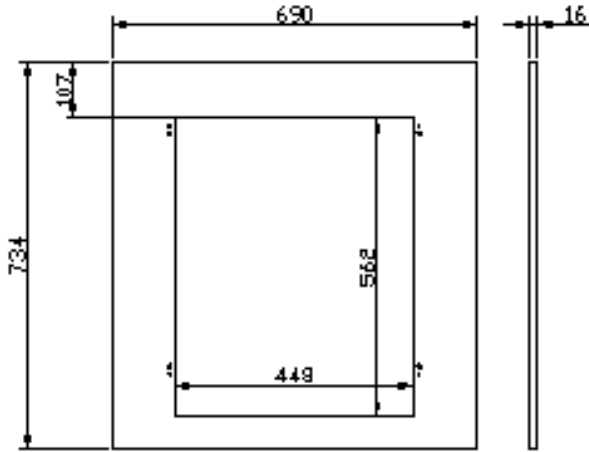

Arc Wall Frame (Fireplace Version)
Minimum Flat Area = 695mm(h) by 675mm(w)

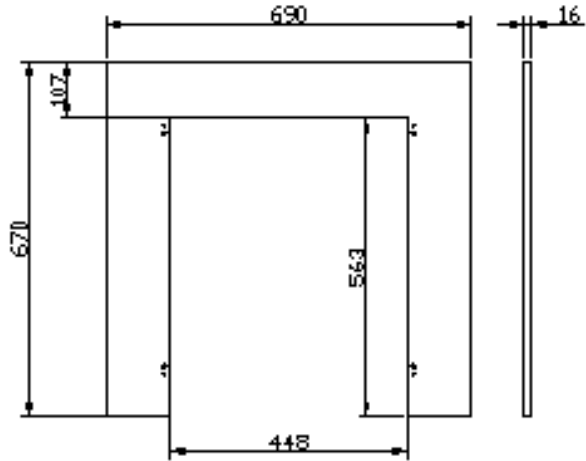

Arc Trim for use with or without the Arc Trim (Hole in Wall Version)
Minimum Flat Area = 545mm(w) by 615mm(h)

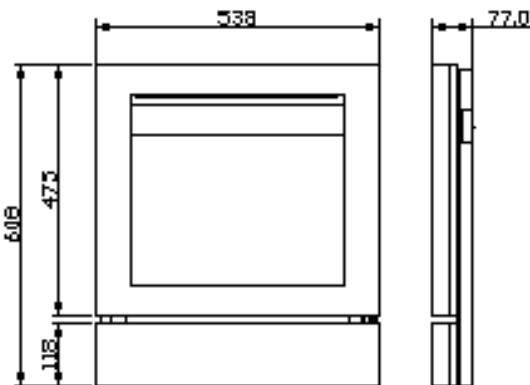

Arc Trim for use with or without the Arc Trim (Fireplace Version)
Minimum Flat Area = 545mm(w) by 615mm(h)

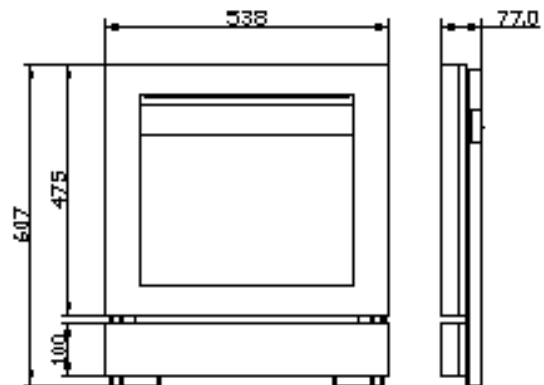

The Standen Trim Supplied with fixing brackets and screws.
(Minimum Flat = 612(w) by 630 (h))

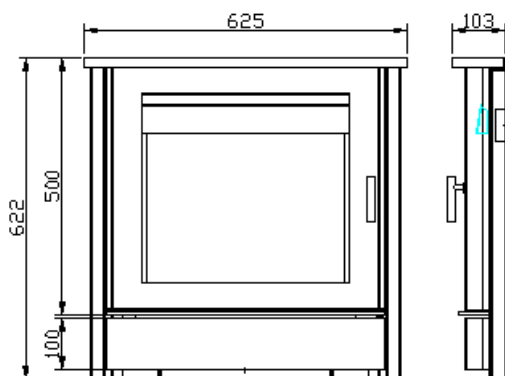

Vitesse CF Outer/Wall Frame
(Minimum Flat = 690(w) by 840 (h))

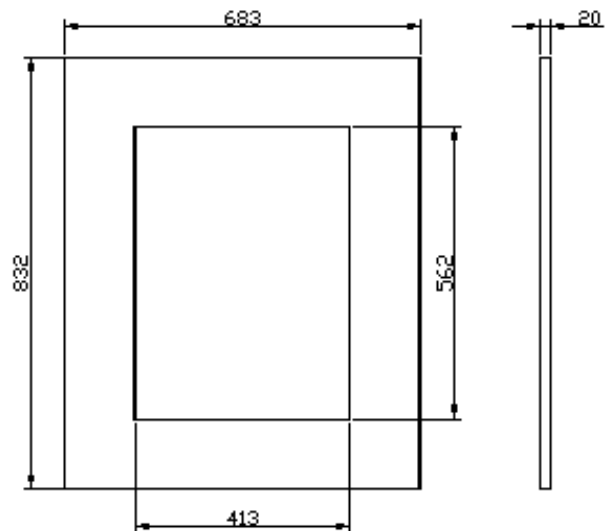

8. - FLUE REQUIREMENTS

These checks MUST be made before constructing the Builders Opening

The Appliance is suitable for Installation into the following types of Flue:

- a. Conventional Stone/Brick Built Flue (Class 1) with a minimum cross sectional dimension of 175mm (7") with a minimum effective height of 3 meters.
- b. The flue **MUST** be free of any obstructions. Any dampers or restrictors **MUST** be removed. Some dampers are impractical to be removed; therefore they **MUST** be fixed in some way in the **OPEN** position.
- c. The chimney/flue should be swept if it has been used for solid fuel.
- d. A Flue Lined with a 5" Flexible Flue Liner connected to a Register Plate fitted and sealed at the top of the Builders Opening with a minimum effective height of 3 meters.
- e. A Pre-cast Flue with Starter Blocks conforming to BS1289: 1975, 1986, or 1989 or BS EN1858 and having a minimum cross sectional flue of 198mm by 67mm and Starter Blocks providing 115mm deep by 304mm wide with a minimum height of 555mm. No part of the Pre-cast Flue must be less than 63mm.
- f. The Fire may be used in conjunction with a Fully Sealed Rebated 150C rated or Equivalent Purpose Built Fire Surround.
- g. Any Pre-Cast Flue must be Sound and Free from Obstructions (Mortar Fangs or Protrusions into the Flue Way) and have an effective height of over 3 meters.
- h. For Pre-cast Flues the walls should be dry-lined over the route of the flue to prevent cracking.
- i. A Purpose Designed Flue Box to BS715 fitted with a 5" twin walled flue with a minimum effect height of 3 meters. Details are available from your authorised supplier.
- j. Ensure that only one fireplace is served by the flue system.
- k. Ensure that the chimney/flue is continuous from inlet to termination.
- l. Ensure that the chimney/flue is structurally sound, so that combustion products do NOT come into contact with combustible materials outside the chimney.
- m. **CHECK FLUE PULL.** Apply a smoke match or smoke generator to the flue opening at hearth level and observe smoke. If there is a definite flow into the flue aperture, proceed with installation. If there is not a definite flow into the flue aperture, preheat the flue for approximately 10 minutes and re-test. If there is not a definite flow towards the flue aperture the flue may need attention.

DO NOT FIT THE APPLIANCE, SEEK EXPERT ADVICE.

9. - VENTILATION

- a. No additional purpose provided ventilation is normally required for the fire when installed in the UK; however this **must** be confirmed by the Spillage Test, see Section 18.2.
- b. For other Countries refer to National Regulations and Local Codes.
- c. This appliance is fitted with an oxygen depletion sensing system, which automatically shuts off the gas supply to the fire if the oxygen level in the room is depleted, due to lack of primary air, or obstructed flue that would lead to incomplete combustion of the gas. It **must not** be tampered with and only replaced with a genuine Nu-Flame ODS Pilot.

10. - GAS SUPPLY

It Is Recommended to Check The Next Section as Building Work May Affect the Gas Supply Routing.

- a. Carry out a gas soundness test before working on the gas supply.
- b. Gas supply provision should be made in accordance with the latest Gas Safety (Installation and Use) Regulations as amended.
- c. Confirm that the fire has been supplied for the correct gas to be used by checking the Data Badge in the base of the fire.
- d. A route for a concealed gas supply is provided through a hole in the rear of the fire, at a position of 65mm to the left of the centre of the fire and 28mm up from the base of the Fireplace/Builders opening. An isolation elbow is provided at the control inlet. Your 8mm gas supply pipe needs to protrude through the back of the convector box by approximately 145mm to achieve a neat connection onto the back of the isolator elbow on the burner. (This applies to both Manually Controlled and Thermatronic Radio Frequency Controlled burners.)
- e. Where the gas supply passes through walls, floors, voids, concrete and wall cavities the supply should be sleeved.
- f. Determine the gas supply pipe size required taking into account any other gas appliances.
- g. Determine where the gas supply pipe needs to terminate and fit the 8mm compression isolation/pressure test elbow provided.
- h. In common with all other gas appliances, dirt and debris in the gas system can block the valve and gas injectors on this appliance, and faults caused by this are not covered by the guarantee. Therefore it is important that all gas pipes **must** be purged of both air and debris.
- i. If you suspect that there may still be dirt and/or debris in the gas system, fit a filter in the pipeline, before the gas isolation/pressure test elbow.
- j. Do **not** use jointing compound on any compression fittings on the fire. The use of jointing compound on the compression joints on this appliance will possibly invalidate the guarantee, as it can get into the control mechanism and cause a malfunction.
- k. Seal off the isolation/pressure test elbow and check all gas connections for gas soundness before proceeding to fit the fire.

! IMPORTANT NOTE ! Always reseal the pressure test point and check that it is gas tight.
(This accounts for a lot of recalls.)

Sections 11 - 14 are for the various Installation Applications - Only one will apply.

! IMPORTANT NOTE ! The chosen installation should have been predetermined and arranged before installing the fire.

Ensure you refer to the section relevant to your requirement.

The Installation Applications Options Are:

- 11.0 Installation into a Class 1 or Lined Flue with a 150°C rated Fire Surround fitted to a Suitable Fireplace Opening.
- 12.0 Installation into a Pre-cast Flue Fireplace. (Rebated Fire Surround Rated 150°C or Purpose Built Surround Extension.)
- 13.0 Installation into a BS 715 Shallow Flue Box with Twin Wall 5" Flue, False Chimney Breast with either a 150°C rated Fire Surround or part way up the wall as a Hole in the Wall Installation with Slips & Shelf.
- 14.0 Installation into a Hole in the Wall application with a Class 1 or Lined Flue requiring a Purpose made Builders Opening.

11. FIRE SURROUND APPLICATION INTO CLASS 1 OR LINED FLUES

FIREPLACE CONSTRUCTION

11.1 - FIRE SURROUND APPLICATIONS

Fireplace Construction

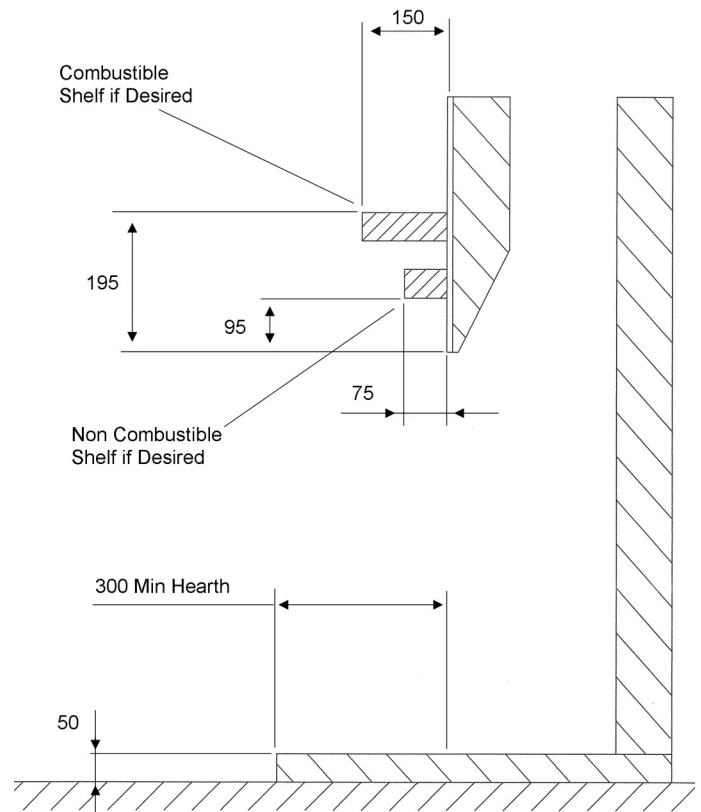
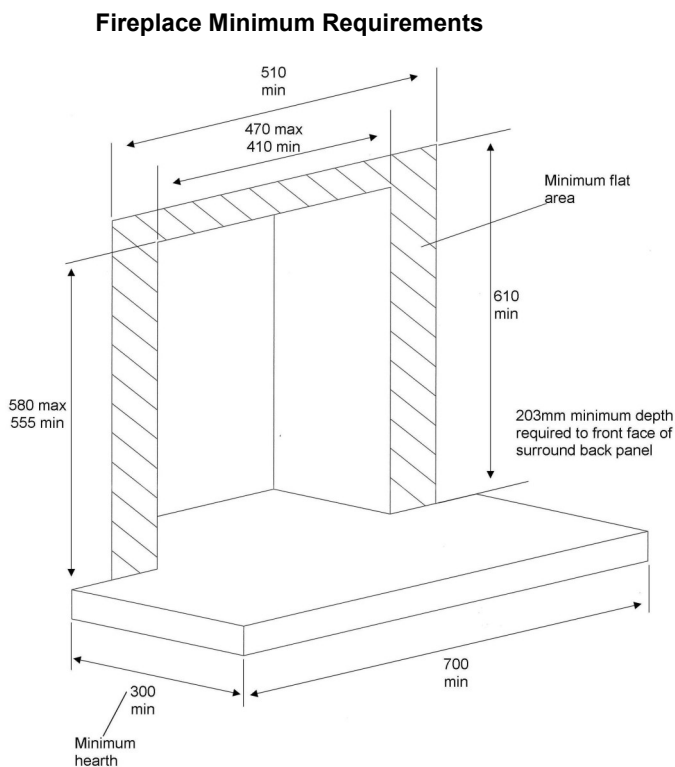

There must be no combustible materials inside the fireplace opening.

11.2 - FIRE SURROUND REQUIREMENTS (See diagram in section 11.1)

- a. If the Fire is to be fitted into a purpose made Fire Surround it must have a temperature rating of 150°C.
- b. Where the fire is to be fitted into an existing 16" chair brick a depth of 240mm is required to allow sufficient volume for Debris, if sufficient depth is not available the rear of the Chair Brick should be removed or extra depth added to the front.
- c. The Fire requires a non-combustible hearth of at least 12mm thick.
- d. The surface of the hearth must stand at least 50mm above the floor and level with the fireplace opening.
- e. The hearth must project at least 300mm in front of the fireplace opening and 150mm either side (700mm minimum hearth width).
- f. The base of the fireplace must be flat, level and square to the face of the fireplace opening.
- g. The Surround must cater for a minimum flat surface around the Fireplace Opening allowing 610mm high by 510mm wide. This is essential in order to achieve a good seal between the face of the surround and the sealing flanges of the fire.
- h. The Fire Surround must be fully sealed to the Fireplace Opening to ensure a good flue seal.
- i. The Fireplace Opening should have provision for a gas supply through the rear, see Section 10 Gas Supply.
- j. The Thermatronic fire is fitted with Electronic Equipment, which is sensitive to dampness and high humidity so it is very **important** that any rendering/building work is allowed to thoroughly dry out before Installation.

! IMPORTANT NOTE ! Dry lined walls – ensure that any air gaps between the back of the plasterboard and wall are sealed around the builders opening or fireplace as this can affect flue pull and wall staining.

11.3 - CLEARANCES TO COMBUSTIBLE MATERIALS AND SHELVES (Ref: Diagram in section 11.1)

- a. A **non combustible** shelf can be fitted above the fire and should be positioned at least 95mm above the builders opening. We recommend the depth of the shelf should be a maximum of 75mm as anything deeper will reduce convection air and the efficiency of the fire. For deeper non-combustible shelves they must be raised a further 25mm for every extra 25mm of depth.
- b. A 150mm **combustible** shelf can be fitted above the fire but must be positioned at least 195mm above the builders opening. For deeper combustible shelves they must be raised a further 25mm for every extra 25mm of depth.
- c. The sidewalls of a combustible fire surround can be 250mm from the inside of the builders/fireplace opening provided its depth is no more than 150mm, however this must be increased by 25mm per side for every extra 25mm of depth.
- d. With all heating appliances, soft furnishings, decorations and wall coverings may discolour or scorch if placed too close.
- e. No combustible material, e.g. curtains must be closer than 500mm to the builders opening.
- f. Any combustible wall claddings (wall paper) must be cut back to a height of 750mm and 300 mm either side of the Fireplace Opening.
- g. Due to the heat output of The Vitesse CF it is **not recommended** to use blown vinyl wall covering around the fire.

NOW PROCEED TO SECTION 15 - FIXING THE FIRE.

**12. INSTALLATION INTO A PRE-CAST FLUE
(Rebated Fire Surround Rated 150°C or Purpose Built Surround Extension)
FIREPLACE CONSTRUCTION**

12.1 - EXISTING MINIMUM PRE-CAST FLUE FIREPLACE REQUIREMENTS

! IMPORTANT NOTE ! THERE ARE NUMERIOUS DIFFERENT SIZES OF PRECAST FLUE FIREPLACES AND THE FOLLOWING DETERMINES THE MINIMUM REQUIREMENTS AND THE ADDITIONAL BUILDING WORK REQUIRED.

**Pre-Cast Fireplaces
Minimum Requirements**

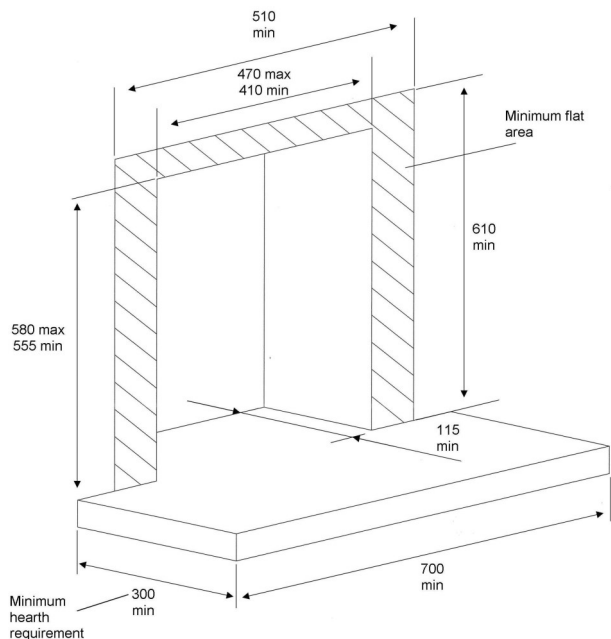

**Pre-Cast Flue Application
Rebated Fire Surround or
Equivalent**

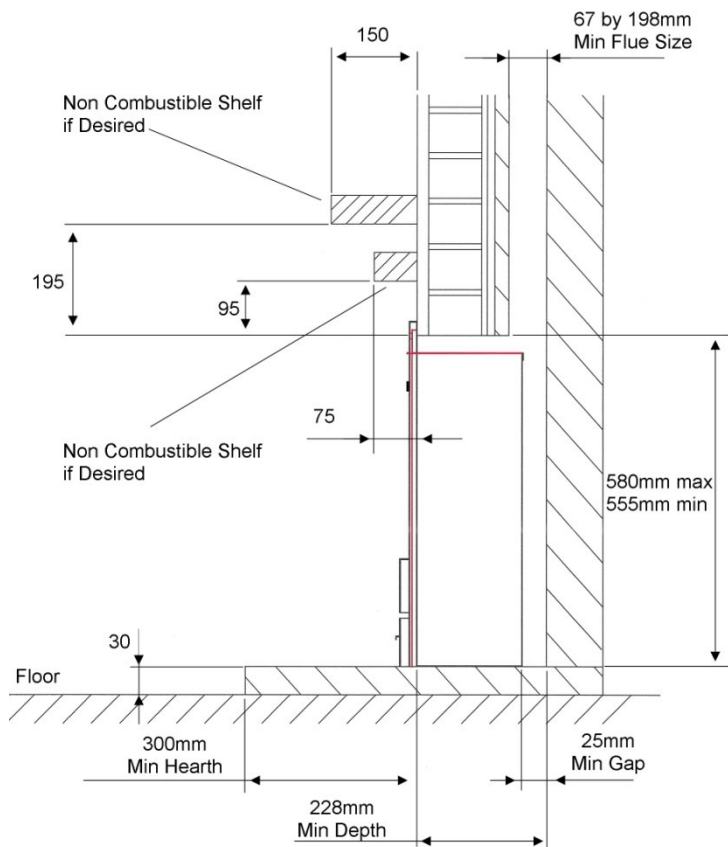

**Pre Cast Flue Fireplace
Depth Construction**

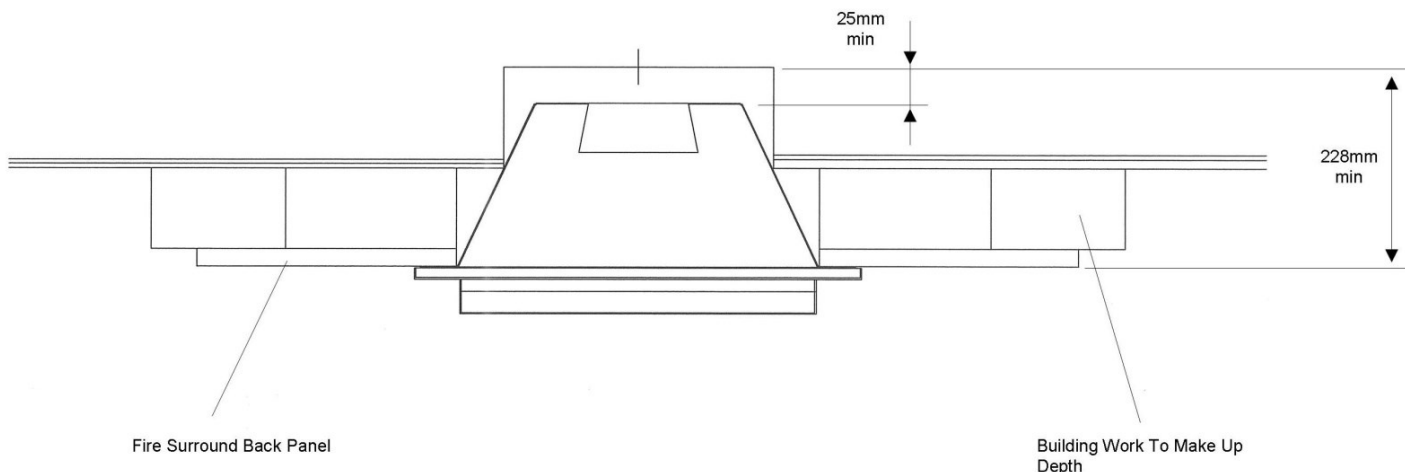

There must be no combustible materials inside the builders opening.

12.2 - FIREPLACE MINIMUM REQUIREMENTS (See diagram in section 12.1)

With the Majority of Pre-Cast Flue Fireplaces there will be insufficient depth-width and building work with either a Purpose Made Non Combustible Fire Surround or Rebated Fire Surround Will be Required to Create the Necessary Fireplace Prior to Installation.

- a. The Minimum Pre-cast Flue Size is 67mm deep by 198mm wide with Starter Blocks providing a Minimum Depth of 115mm by 305mm wide. No part of the Flue must be less than 63mm.
- b. The height of the Pre-cast Fireplace opening must be between 555mm and 580mm. If the Starter Blocks have not been provided down to Floor level then building work will be required.
- c. Where the Pre- cast Flue Fireplace with Starter Blocks only provide the minimum depth of 115mm and width of 305mm a purpose built extension will be required to provide the additional depth of 113mm as shown above. This Extension must be made of Non Combustible materials and fully sealed to the Existing Fireplace.
- d. With more up to date Pre-cast Fireplaces a minimum full depth width of 408mm and the minimum depth of 220mm may be available requiring no additional building work.
- e. Where the Pre-cast Fireplace is wider than 305mm but not 406mm then the additional depth of building work required can be reduced accordingly. A gap of 25mm must always be left behind the fire.
- f. If the Fire is to be fitted with a purpose made Rebated Fire Surround it must have a temperature rating of 150°C.
- g. The Fire Surround must be fully sealed to the Fireplace Opening to ensure a good flue seal.
- h. The Fire requires a non-combustible hearth of at least 12mm thick.
- i. The surface of the hearth must stand at least 50mm above the floor and level with the fireplace opening.
- j. The hearth must project at least 300mm in front of the fireplace opening and 150mm either side (700mm minimum hearth width).
- k. The base of the fireplace must be flat, level and square to the face of the fireplace opening.
- l. The Surround must cater for a minimum flat surface around the Fireplace Opening allowing 610mm high by 510mm wide. This is essential in order to achieve a good seal between the face of the surround and the sealing flanges of the fire.
- m. The Fireplace Opening should have provision for a gas supply through the rear, see Section 10 Gas Supply.
- n. The Thermatronic controlled fire is fitted with Electronic Equipment, which is sensitive to dampness and high humidity so it is very **important** that any rendering/building work is allowed to thoroughly dry out before Installation.

! IMPORTANT NOTE ! Dry lined walls – ensure that any air gaps between the back of the plasterboard and wall are sealed around the builders opening or fireplace as this can affect flue pull and wall staining.

Pre-Cast Flues – ensure the walls are dry lined over the route of the flue otherwise wall cracking will occur.

12.3 - CLEARANCES TO COMBUSTIBLE MATERIALS AND SHELVES (Ref: Diagram in section 12.1)

- a. A **non combustible** shelf can be fitted above the fire and should be positioned at least 95mm above the builders opening. We recommend the depth of the shelf should be a maximum of 75mm as anything deeper will reduce convection air and the efficiency of the fire. For deeper non-combustible shelves they must be raised a further 25mm for every extra 25mm of depth.
- b. A 150mm **combustible** shelf can be fitted above the fire but must be positioned at least 195mm above the builders opening. For deeper combustible shelves they must be raised a further 25mm for every extra 25mm of depth.
- c. Any combustible sidewall must be at least 500mm from the inside of the builders/fireplace opening, however with a combustible fire surround it can be 250mm from the inside of the builders/fireplace opening provided it does not protrude more than 150mm and must be increased by 25mm for every extra 25mm of depth.
- d. With all heating appliances, soft furnishings, decorations and wall coverings may discolour or scorch if placed too close.
- e. No combustible material, e.g. curtains must be closer than 500mm to the builders opening.
- f. Any combustible wall claddings (wall paper) must be cut back to a height of 750mm and 300 mm either side of the Fireplace Opening.
- g. Due to the heat output of The Vitesse CF it is **not recommended** to use blown vinyl wall covering around the fire.

NOW PROCEED TO SECTION 15 - FIXING THE FIRE.

13. BS 715 SHALLOW FLUE BOX WITH TWIN WALL 5" FLUE - FALSE CHIMNEY BREAST CONSTRUCTION WITH FIRE SURROUND OR HOLE IN THE WALL APPLICATIONS

13.1 FALSE CHIMNEY BREAST CONSTRUCTION

Shallow Flue Box Application

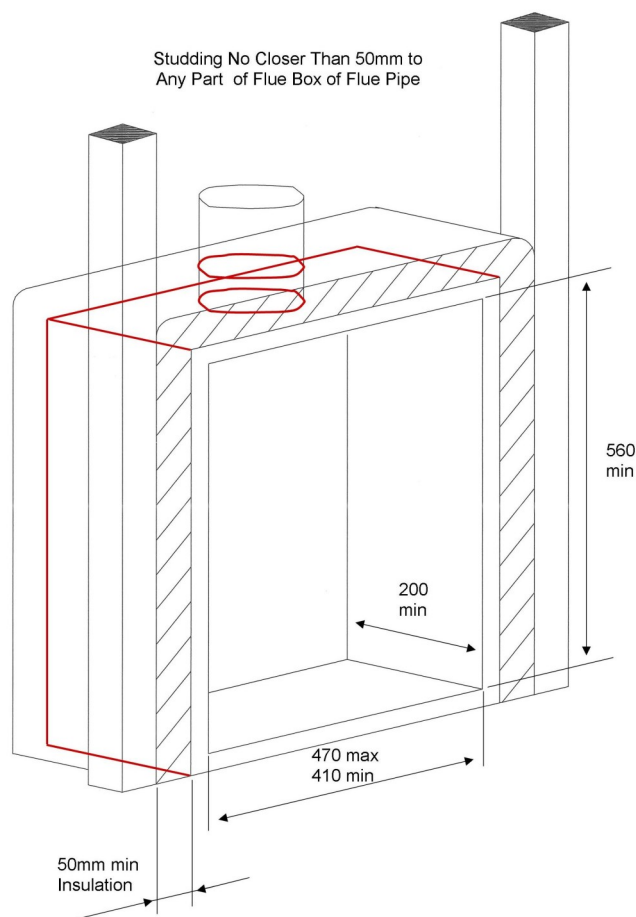

BS715 Flue Box Hole In The Wall Construction

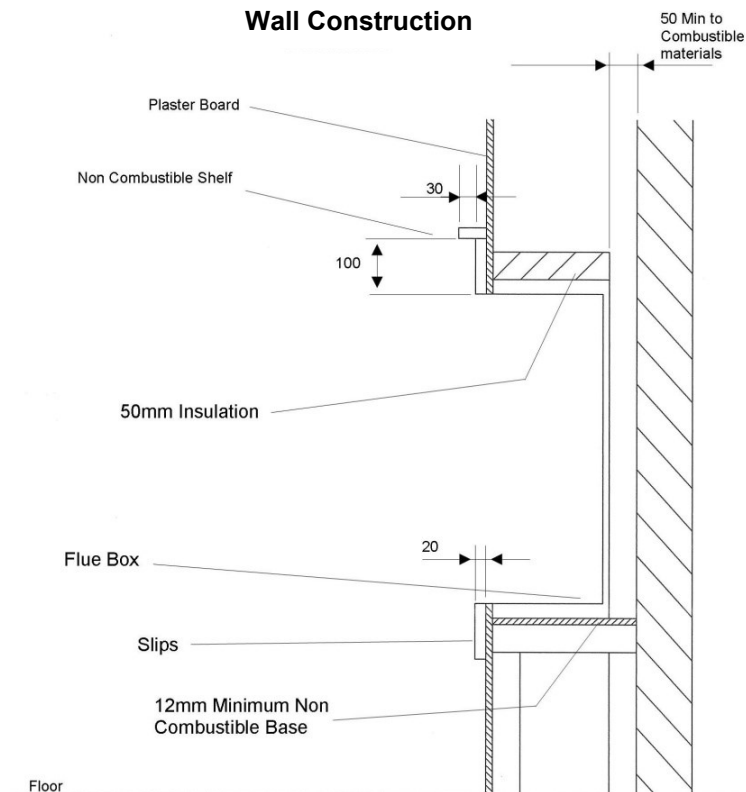

There must be no combustible materials used inside the flue box.

13.2 – BS 715 FLUE BOX BUILT INTO A FALSE CHIMNEY BREAST WITH FIRE SURROUND OR HOLE IN THE WALL INSTALLATION WITH REQUIREMENTS (See diagrams above).

A BS 715 Flue Box can be built into a false chimney breast and installed at floor level with a suitable Fire Surround.

or

The Fire can be Built-In part way up the wall to create a Hole in the Wall Installation, however it is essential to use marble, slate or stone slips, fitted around the builders opening. The slips must have a temperature rating of 150°C and be 20mm (min) thick by 100mm (min) wide.

In order to direct the flow of heated air away from the wall we recommend that a non combustible shelf (lip) is fitted above the top slip, protruding 30mm – see diagram.

- A suitable BS715 Shallow Flue Box should be used with the minimum dimensions quoted above.
- The base of the flue box must be level and square to the face of the fireplace opening.
- The Flue Box must sit on Non Combustible Material of at least 12mm Thick.
- The Flue Box can be placed against a Non Combustible wall at the rear, however if the wall is combustible it must be spaced 50mm from the wall.
- When building a False Chimney Breast No Combustible materials must be closer than 50mm to the Flue Box.
- No Combustible materials must be closer than 50mm to the Twin Wall Flue over its entire route through the Property.
- The Flue Box must be Insulated on its top and sides with 50mm thick Non Combustible Fibreglass Insulation or Equivalent.
- If plaster board is used in front of the flue box it must be sealed to the box with high temperature Silicone Sealant or an equivalent flexible sealant.
- If the Fire is to be fitted into a purpose made Fire Surround it must have a temperature rating of 150°C.
- For a Fire Surround the fire requires a non-combustible hearth of at least 12mm thick.
- The surface of the hearth must stand at least 50mm above the floor and level with the fireplace opening.
- The hearth must project at least 300mm in front of the fireplace opening and 150mm either side (700mm minimum hearth width).

- k. The Surround must cater for a minimum flat surface around the Fireplace Opening allowing 610mm high by 510mm wide. This is essential in order to achieve a good seal between the face of the surround and the sealing flanges of the fire.
- l. The Fire Surround must be fully sealed to the Fireplace Opening to ensure a good flue seal.
- m. For a Hole in the Wall Installations It is essential to use marble, slate or stone slips, fitted around the builders opening. The slips must have a temperature rating of 150°C and be 20mm (min) thick by 100mm (min) wide.
- n. In order to direct the flow of heated air away from the wall we recommend that a non combustible shelf (lip) is fitted above the top slip, protruding 30mm – see diagram.
- o. There must be a flat surface around the opening of sufficient area to enable the slips to be securely fitted. The slips should be fitted to the wall in such a way that they form a seal to stop air from the room being drawn behind the slips into the False Chimney Breast. We recommend a high temperature silicon sealant.
- p. The **recommended** height for the base of the Builders Opening is 350mm above floor level. The **minimum** height for the base of the Builders Opening is 250mm above floor level.
- q. The Fireplace Opening should have provision for a gas supply through the rear, see Section 10 Gas Supply.
- r. The Thermatronic fire is fitted with Electronic Equipment, which is sensitive to dampness and high humidity so it is very **important** that any rendering/building work is allowed to thoroughly dry out before Installation.

! IMPORTANT NOTE ! Do not forget to take account of the difference in height of the base of the Flue Box when mounting the box on the floor; it must be level with the Hearth.

13.3 - CLEARANCES TO COMBUSTIBLE MATERIALS AND SHELVES (Ref: Diagram Above) **The Requirement for Shelves for Hole in the Wall Installations is Detailed in the Above Section.**

- a. For Fire Surrounds a **non combustible** shelf can be fitted above the fire and should be positioned at least 95mm above the builders opening. We recommend the depth of the shelf should be a maximum of 75mm as anything deeper will reduce convection air and the efficiency of the fire. For deeper non-combustible shelves they must be raised a further 25mm for every extra 25mm of depth.
- b. For Fire Surrounds a 150mm **combustible** shelf can be fitted above the fire but must be positioned at least 195mm above the builders opening. For deeper combustible shelves they must be raised a further 25mm for every extra 25mm of depth.
- c. Any combustible sidewall must be at least 500mm from the inside of the builders/fireplace opening, however with a combustible fire surround it can be 250mm from the inside of the builders/fireplace opening provided it does not protrude more than 150mm and this must be increased by 25mm for every extra 25mm of depth.
- d. With all heating appliances, soft furnishings, decorations and wall coverings may discolour or scorch if placed too close.
- e. No combustible material, e.g. curtains must be closer than 500mm to the builders opening.
- f. Any combustible wall claddings (wall paper) must be cut back to a height of 750mm and 300 mm either side of the Fireplace Opening.
- g. Due to the heat output of The Vitesse CF it is **not recommended** to use blown vinyl wall covering around the fire.

NOW PROCEED TO SECTION 15 - FIXING THE FIRE.

14. HOLE IN THE WALL APPLICATIONS INTO CLASS 1 or LINED FLUE BUILDERS OPENING

14.1 - SLIPS & WALL COVERINGS

It is essential to use marble, slate or stone slips, fitted around the builders opening. The slips must have a temperature rating of 150°C and be 20mm (min) thick and typically form a border round the opening of 100mm. In order to direct the flow of heated air away from the wall we recommend that a non-combustible shelf (lip) is fitted above the top slip, protruding 30mm beyond the front face of the slip – see diagram in section 14.3.

With any form of heating appliance convection air will rise up through the fire carrying particles of dust that will in time result in varying degrees of wall staining. The non-combustible shelf is designed to minimise this by deflecting the airflow away from the wall. However, over time some staining might occur and we therefore suggest not using patterned paper around the fire.

Due to the heat output of The Vitesse Plus H.E. it is **not recommended** to use blown vinyl wall covering around the fire.

Where the Chimney Breast is made of Stone or Slate or other Suitable Non Combustible Material with NO wall coverings then Slips are Not Required but the Dimensions of the Builders Opening must be as shown below and a Flat Surface of at least 50mm must be provided around the opening for sealing.

14.2 - HOLE IN THE WALL APPLICATION (USING MARBLE SLATE OR STONE SLIPS & SHELF)

Builders Opening for Hole in the Wall application (when using marble, slate or stone slips)

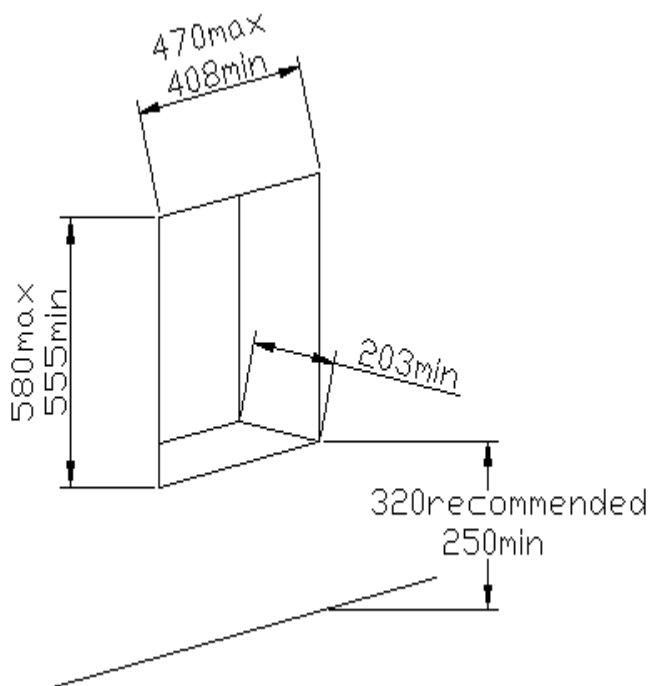

- It is recommended that a qualified builder constructs the builders opening.
- It is recommended that a lintel is fitted above the builders opening.
- The builders opening must be constructed from Non-combustible materials.
- No** combustible materials must be present in the builders opening.
- The base of the builders opening must be flat, level and square to the wall and be at least 12mm thick.
- The builders opening should have provision for a gas supply through the rear, see Section 10 Gas Supply.
- There must be a flat surface around the builders opening of sufficient area to enable the slips to be securely fitted. The slips should be fitted to the wall in such a way that they form a seal to stop air from the room being drawn behind the slips into the builders opening. We recommend a high temperature silicon sealant.
- The **recommended** height for the base of the Builders Opening is 320mm above floor level. The **minimum** height for the base of the Builders Opening is 250mm above floor level.
- Thermostatically controlled models are fitted with Electronic Equipment, which is sensitive to dampness and high humidity so it is very **important** that any rendering/building work is allowed to thoroughly dry out before installation.

! IMPORTANT NOTE !

Dry lined walls – ensure that any air gaps between the back of the plasterboard and wall are sealed around the builders opening or fireplace as this can affect flue pull and wall staining.

Hole in the Wall Installation into Class 1 or Lined Flue

14.3 - CLEARANCES TO COMBUSTIBLE MATERIALS

- Any combustible sidewall must be at least 500mm from the inside of the builders/fireplace opening.
- With all heating appliances, soft furnishings, decorations and wall coverings may discolour or scorch if placed too close.
- No combustible material, e.g. curtains must be closer than 500mm to the builders opening.

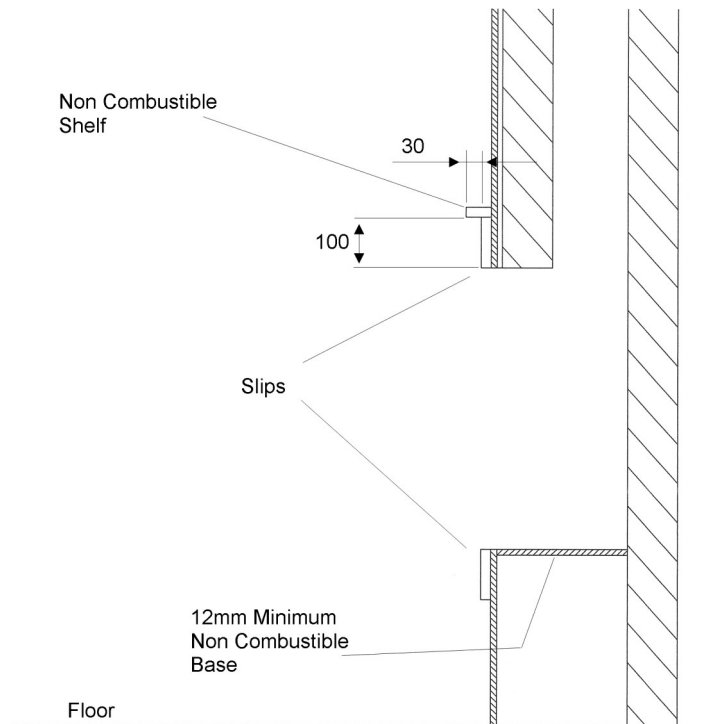

NOW PROCEED TO SECTION 15 - FIXING THE FIRE.

15. FIXING THE FIRE

Important

If The Vitesse CF is having a Modern Style Trim with a louvered top the stainless steel

Top Louvre / Heat Shield provided with the Trim must be fitted with the 2 # No6 x 5mm blunt self tapping screws before fitting the convector box into the opening, as shown.

Screw through the top of the case into the Top Louvre / Heat Shield. The Top Louvre / Heat Shield is packed in the same box as the Modern Trim and the fixing screws are in with the fitting kit packed with the Fire.

Note: The Top Louvre / Heat Shield is not needed if a Contemporary Trim with a canopy top is being used.

15.1 - FITTING THE Silicone Sealing Strip

Note: If the fire is to be fitted with either an Arc or Vitesse Wall Frame as detailed on Page 10 then consult the Instructions supplied with the Wall Frame as this will need to be fitted before this next stage and Fixing the Fire.

It is very important that a good seal is achieved between the convector box and the front of the fireplace back panel for safety reasons and to achieve maximum efficiency. Take the self adhesive silicone sealing strip from the fitting kit and neatly apply to the back flanges of the convector box outer frame (as close to the edge as possible), cutting to the appropriate lengths as required.

To ensure there is a good seal between the base of the fire and the bottom of the fireplace opening apply a length of self adhesive silicone sealing strip on the base of the fire at the front edge.

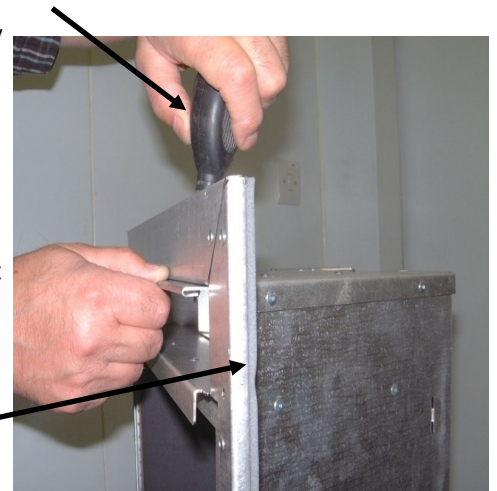

15.2 - FITTING THE ARC & STANDEN TRIM BRACKETS

The fixing brackets and screws will be supplied with the Trim. Take the 2 brackets and fix as shown. The Brackets are supplied with slots for adjustment which can be adjusted when the Trim is fitted. Two screws are also provided for fixing the Trim at the bottom right hand and left and corners

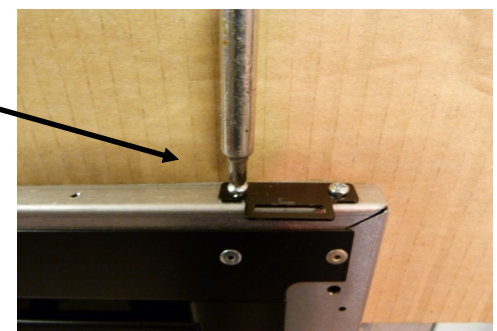

15.3 - FITTING THE FIRE - references should be made to the drawings below.

! IMPORTANT NOTE ! TAKE GREAT CARE WHEN WORKING INSIDE THE FIRE NOT TO MARK THE CERAMIC LINING PANELS.

- a. Using a Dust Sheet or equivalent protect the area around the Fire Installation.
- b. Remove the Fire from the box and lay it on its back. Using the Screw Driver provided slacken the 2 Screws at the Bottom Left and Right Corners Securing the Glass Panel and Swivel them Off the Glass Panel then Ease the Glass Panel outward slightly at the base then Pull down and remove.
- c. Now with the fire on its Base, remove the Burner/Control Assembly by firstly removing the 2 screws at the rear of the fire taking care not to mark the liners.
Slide the Burner Assembly forward then lift out to remove taking care not to Mark the Liners, if the fire is fitted with the Thermatronic Control it will be necessary to pull the Receiver Box off its Velcro Pads.
- d. Remove the Debris Plate at the back by removing the 2 screws allowing access through the Debris Opening for fitting the Gas Supply.
- e. There are fixing holes in the front flanges which can be used if there is sufficient strong material for fixing, however we recommend the cable fixing system which is supplied to secure the unit into the fireplace. The cable fixing system will also pull the unit tight back into the fireplace to make a good seal. This is very important to ensure efficient and safe operation of the fire. There are 2 cables supplied; 1 to be used each side of the unit. Working at 200mm centres in the builders opening drill the lower holes 27mm up from the base and drill the higher holes 510mm up from the base see drawing below. Secure the 4 Eyebolts supplied with the Raw plugs to the back of the fireplace. Ensure the Eyebolts are fully screwed in.
IMPORTANT: ENSURE THE MATERIAL THE EYEBOLT/RAWPLUG IS FIXED INTO IS SOLID AND SOUND. If the fixing is not sound the Rawplug/Eyebolt will be pulled out and the fire will not be sealed to the Fireplace Opening.
Note: With the minimum depth fireplace enclosure it may be necessary to sink the Eye Bolt Heads into the Brickwork.
- f. There are 2 cable attachment points on the top of the main casing; 1 each side at the rear. They are part of the folded lip of the top section, prize these up with a screwdriver to enable them to be used. Feed a cable downwards through each cable attachment point.
- g. Feed the cables though the eyebolts on either side and then through the holes in the back of the fire near the base.
- h. Slide the Fire **part way** into the fireplace (leaving it sticking out approximately 50mm) ensuring the gas supply pipe and isolation/pressure test elbow clears through the Debris Opening in the rear of the Fire.
- i. Slide the Fire fully home ensuring that the sealing strips on the rear of the Fire outer frame stay in position to make a seal against the fireplace back panel. While sliding the unit into the fireplace opening pull on the excess cable.
- j. Locate the supply pipe into the slot in the Debris Opening and replace the Debris Plate.
- k. The Cable Fix Adjuster and Lock Screw can now be fitted onto the cable and tightened up to tension the fire back into the fireplace. The fire should be secure and not liable to movement.
Surplus fixing cable MUST NOT be cut off and must be tucked back through the central hole in the Back of the Fire. This is particularly important with the Thermatronic Control System to keep the cables away from any electronics.
- l. If any of the silicone sealing strips are not compressed and/or if there are gaps they must be filled with a suitable sealant, ideally high temperature silicone or fireclay. Refit the Burner/Controls Assembly with the 2 screws and with the Thermatronic Control System refit the Receiver Box onto the Velcro Pads.
- m. Connect the isolation/pressure test elbow to the control valve and with it fully open check the joint for gas soundness.
- n. Check that all gas connections are sound. The appliance has been factory tested; however the connections may have been disturbed in transit or storage.

! IMPORTANT NOTE ! Always reseal the pressure test point and check that it is gas tight. (This accounts for a lot of recalls.)

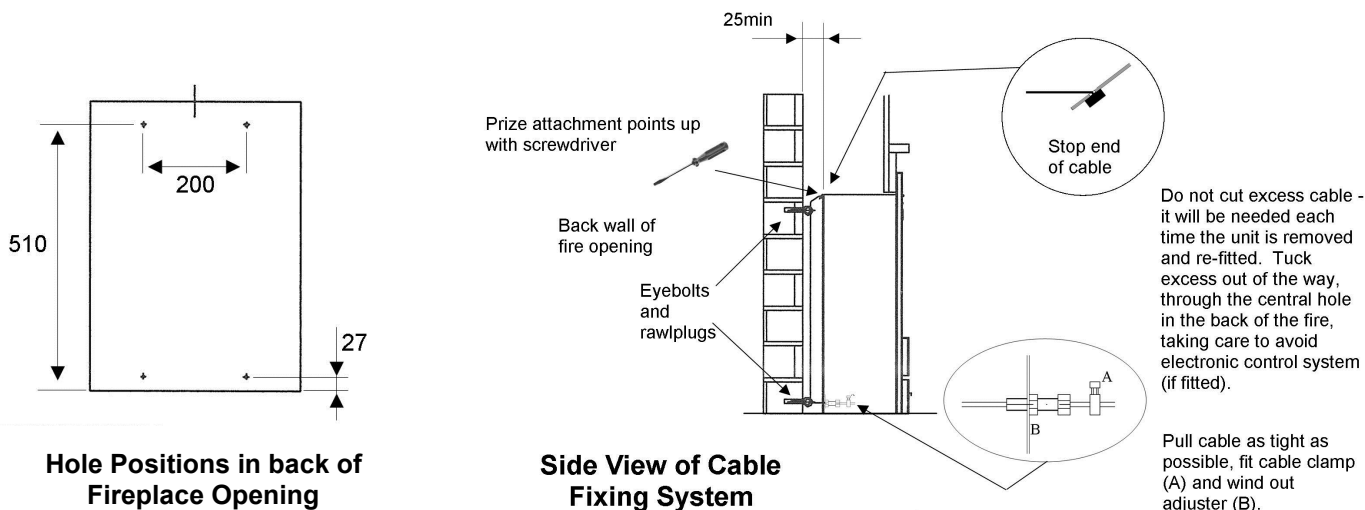

16. - ARRANGEMENT OF THE FUEL EFFECT.

Health & Safety Advice Refractory Ceramic Fibre (RCF)

Advice when working with Fuel Bed Components including Installing, Servicing and Disposal.

The Fuel Effect parts and possible Linings of this fire are made from Refractory Ceramic Fibre (R.C.F.) a Class 2 Carcinogen which is a material designed for this Application. Excessive exposure to these types of materials may cause temporary irritation to eyes, skin and respiratory tract. Therefore take care when handling these articles to ensure dust is kept to a minimum.

It is not necessary to wear protective clothing when handling these articles but we do recommend you follow the normal hygiene rules of not smoking, eating or drinking in the work area, and always wash your hands before eating or drinking.

To minimise the release of RCF fibres during installation and servicing a HEPA filtered vacuum is recommended to remove any dust accumulated in and around the fire both before and after working on it.

When Servicing and if replacing these parts we do not recommend they are broken up but are sealed within a heavy duty polythene Bag and labelled as "RCF waste". This is not classified as "hazardous waste" and may be disposed of at a local licensed landfill site.

Fitting the Fuel Effect Parts

Remove all the Fuel Effect parts and Familiarise Yourself with Each Part. You will see that the Moulded Cluster Coals are Numbered 1 to 5 plus Loose Coals as follows, 7 Coals marked 'B', 1 Coal marked 'C', 2 Oblong Coals marked 'H' and 4 Very Small Coals Marked 'G'.

When fitting coals place them so the markings, 'B', 'C', 'H' & 'G', are hidden.

! TIP ! Take care not to damage liner panels when fitting the Burner Assembly and Coal Bed.

- a. Fit the Matrix
Ensure it clears the burner at the front
Left & Right Hand corners.

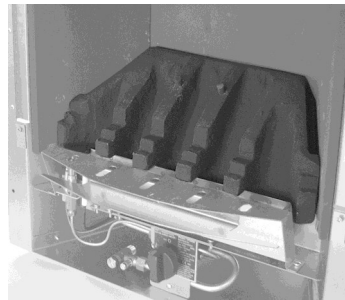

- b. Fit No1 Rear Cluster Coal.
Locating the web behind the matrix.



- c. Fit No2 Left Side Cluster Coal.
Locating the web into the Matrix.



- d. Fit No3 Right Side Cluster Coal.
Locating the web into the Matrix.



- e. Fit No4 Front Cluster Coal.



- f. Fit No5 Centre Cluster Coal.
Note: Pegs on the Matrix locate into
Holes in the Base.



Now to Fit the Loose Coals

When fitting coals place them so the marking, 'B', 'C', 'H' & 'G', are hidden.

- g. Fit the 1off 'C' Coal in the centre
at the centre as shown.



- h. Fit the 2off 'H' Coal either side
of the coal just fitted as shown.



- i. Fit the 4off 'B' Coal two at the Left Hand
and two at the Right Hand side as shown.



- j. Fit the 3off 'B' Coals into the pockets In the Centre Coal Cluster as shown.
Note: Ensure the 'B' marking is hidden.



- k. Fit 4off of the Small 'G' Coals into the Pockets along the front as shown.
Note: Ensure the 'B' marking is hidden.



IMPORTANT: Finally Adjust The Coals to Ensure None Of The Letter Markings Can Be Seen.

- l. Before fitting the glass panel with the 2 screws and screw driver provided, check the condition of the glass and ensure it is clean and free from any finger marks.

17. - FITTING THE BURNER HEAT SHIELD

There are two shapes of burner heat shield and the type you will need is determined by whether you have a Flat Type Trim or a Curved Type Trim. For this reason the appropriate Burner Heat Shield and 2off No8 by 10mm blunt self tapping screws are packed with the Trim.

With the Glass Panel now in place screw the Burner Heat Shield onto the top of the burner mounting plate using the 2 # No8 x 10mm blunt self tapping screws; there is one hole on each side. When fitted the Burner Heat Shield slopes away from the burner. It cannot be fitted the wrong way round as it will foul on the burner.

Note: The photographs below show the Burner Assemblies out of the fire for clarity on how they fit.



Burner with Burner Heat Shield for Flat Trim Fitted

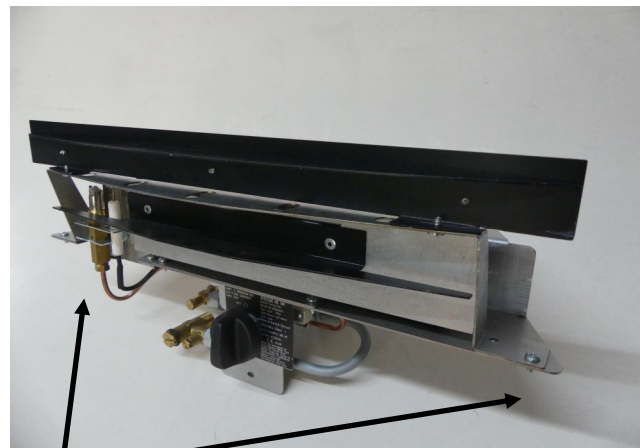

Burner with Burner Heat Shield for Curved Trim Fitted

Screw Fixings

! IMPORTANT NOTE !

Failure to fit the appropriate Burner Heat Shield will invalidate the guarantee.

18. - TESTING, COMMISSIONING & USE

! IMPORTANT NOTE ! During its first period of use any protective coatings and oils will burn out of the fire and it is wise to ventilate the room for the first hour; also advise the customer that this may persist for the first few days until the fire is fully burnt-in.

18.1 - LIGHTING THE FIRE

- Reference to Section 2 in the Users Instructions 'Lighting & Controlling the Fire' will show how to light and operate the fire.
- Check that the supply pressure to the fire is at the pressures required, 20mbar (Natural Gas G20) or 37mbar (Propane G31) when set at high.

! IMPORTANT NOTE ! Ensure that the pressure test point used is sealed and gas tight.

18.2 - TESTING FOR SPILLAGE

- A restrictor is supplied with the fire for flues that have an effective height greater than 3 meters. **The restrictor must not be fitted to Pre-cast Flue applications.** The restrictor is fitted into the duct above the glass panel with the 2 # No6 x 10mm pointed self tapping screws provided, see below.

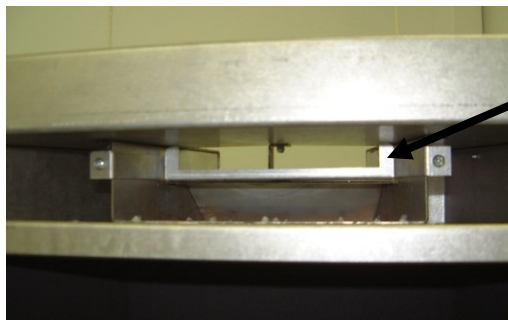

Restrictor fitted – see note 18.2 a above

- Once the fire is operational the installer must check for spillage. Carry out the lighting procedure and turn the fire to high. Allow to warm up for 5 minutes and then using a smoke match, joss stick or similar, place it centrally in the duct above the glass panel as shown above. The majority of the smoke must be drawn into the duct. Some small whiffs of smoke may be expelled and this is quite normal. Be careful not to introduce too much smoke (i.e. by using a pellet). A smoke match tube can be used to make holding of the match easier. See following diagram.

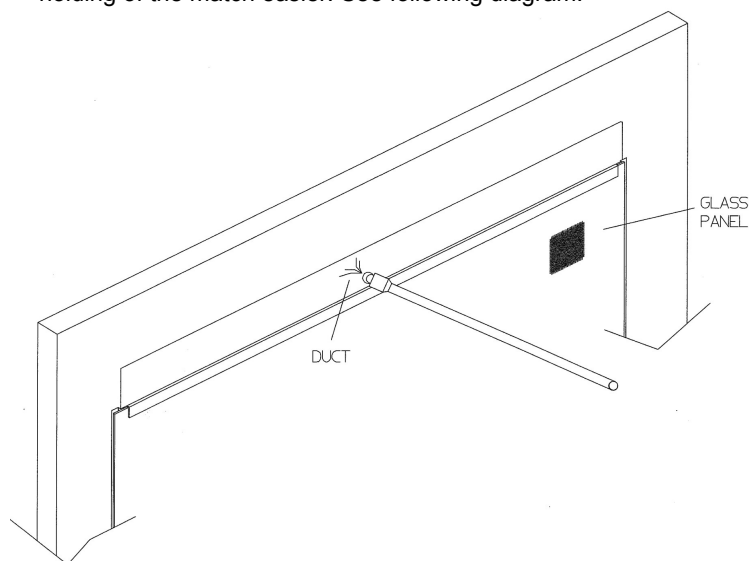

- Repeat the test with doors and windows to the premises/room both open and closed, and with any extractor fans in the same room or adjacent rooms running at high. The fire should continue to clear its combustion products. Also operate any other flued appliance in the same or neighbouring rooms and ensure they continue to function satisfactorily as multiple flues can work against one another.
- If spillage is detected during this procedure, remove the restrictor if fitted and repeat the tests.
- If spillage is detected and no restrictor is fitted, let the fire operate for a further 10 minutes and re-check.
- If the fire continues to spill, it could indicate a faulty flue or lack of ventilation. If the problem cannot be rectified immediately, disconnect the fire, affix a label and advise the customer not to use it until the problem has been resolved.
- It is an offence to use or allow the use of a dangerous appliance.**

18.3 - FITTING THE PIPEWORK COVER PLATE (MANUALLY CONTROLLED FIRES ONLY)

For manually controlled fires a black cover plate is supplied to cover some of the pipework and associated fittings under the burner tray. This is freestanding and is supplied for cosmetic purposes only. The controls can be operated with the cover in place. Please refer to the photographs in section 2.1

18.4 - FITTING THE OUTER TRIM

Some Trim & Wall Frame Options are supplied separately with their own Fixings & Instructions.

- a. For Trims held with magnets position the 4 strong Magnets, one at each corner.
- b. To fit simply centralize the Trim and fit it onto the Fire.
Note : If the Trim is not positioned centrally it may not be held correctly at each corner, however it can be slid from side to side to ensure it is located correctly.

IMPORTANT: Modern Flat Trim: For Modern Trims a Stainless Steel Top Louvre / Heat Shield should have been fitted by the 2 self tapping screws before fitting the convector box into the opening. The Top Louvre / Heat Shield is packed in the same box as the Trim. See photograph at beginning of Section 15.

Arc & Standen Trims (Fireplace or Hole in the Wall Version).

The Fixing Brackets and Screws should have already been fitted as detailed will have section 15.

- a. Place the Trim over the fire and slide it downward to hook the tabs in the Trim into the slots in the Brackets on the fire.
- b. Take the 2 screws supplied and fix to the fire through the 2 holes, at the bottom of the Trim on each side.
- c. The Brackets on the fire are supplied with slots for adjustment and can be adjusted after checking the fit of the Trim.

18.5 - FIREGUARDS

- a. A fireguard is not supplied with the appliance however it is recommended that a fireguard is fitted if the fire is to be used in the presence of young children, the elderly, the infirm and pets.
- b. For Hole in the Wall Installations it is recommended that a means, (tactile separator/shelf or guard) is provided to give abrupt warning to a person moving inadvertently towards the fire.

19 - BRIEFING THE CUSTOMER

- a. The installer should brief the customer on the Operation of the Control System and all aspects of the User Instructions.
- b. The Instructions and Glass Panel release Screw Driver should be handed to the customer for their safe keeping and future servicing.
- c. Show the customer how the glass panel can be removed for cleaning with the screw driver provided.
- d. For Customers who have purchased the Thermatronic Control explain and demonstrate that the batteries in the receiver and hand set should be replaced with good quality ones annually as the fire may stop working part way through the season.
- e. The customer should be briefed on the need for regular servicing; this will normally be once a year.
- f. Advise the customer that, apart from batteries for the High Level and Thermatronic System, there are no user replaceable parts in the fire but for servicing and spares to contact the local Nu-Flame Stockist.
- g. Advise the customer that under no circumstances must the fire be used without the glass panel fitted or if it is in any way chipped, cracked or damaged.
- h. Advise the customer about the importance of checking and maintaining the Carbon Monoxide Alarm safety device.

! IMPORTANT NOTE ! THE GLASS PANEL ON THIS FIRE WILL BECOME VERY HOT DURING OPERATION ENSURE THE CUSTOMER IS ADVISED OF THIS.

20 - SERVICING

The Matrix in the fire is a Moulded Ceramic Fibre component incorporating Silicone Binders and you may notice that it develops cracks during operation. This is natural shrinkage caused by exposure to high temperatures and is quite normal for the material and will in no way affect the operation of the fire.

20.1 - GENERAL

Note: Servicing must be carried out by a registered installer.

- a. The fire does not have to be removed for Servicing.
- b. Check the operation and ignition of the fire before servicing.
- c. Ensure the fire is cold before proceeding.
- d. Lay a dust sheet on the floor before proceeding.
- e. Carry out a gas soundness test before servicing.
- f. For the Arc or Standen Trim check for the 2 screws fixing at each lower side then lift the Trim upward and remove.
Some Trims are held with magnets so Pull off the Outer Trim, (Locate the 4 magnets).
- g. Turn off the gas supply to the fire at the isolation/pressure test elbow.
- h. Remove the Heat Shield Assembly fitted to the Burner Assembly with 2 screws to allow excess for removing the Glass Panel.
- i. If any parts need replacement, use only genuine parts supplied by Nu-Flame Ltd. Some components may look similar to those used in other gas fire, but these are not necessarily the same due to performance variations and must not be used.
This applies particularly to the ODS Pilot, Gas Control System and Ceramics.
- j. Disconnect the gas pipe to the control.

! TIP ! Being Magnetic The 4 Trim Magnets Can Be Easily Misplaced, Locate Them Immediately.

Remind the Customer that in the interests of Safety they MUST maintain their Carbon Monoxide Alarm.

20.2 – ANNUAL SERVICING

Carry out the operations in 20.1 General before proceeding

! IMPORTANT NOTE ! TAKE GREAT CARE WHEN WORKING INSIDE THE FIRE NOT TO MARK THE LINERS.

- a. Remove the glass panel using the screw driver provided, easing slightly out at the base then sliding it down. Check the Glass Panel for any damage, it must be replaced if there are any chips, cracks or any damage before the fire can be used.
- b. Referring to the Section 17, 'Arrangement of the Fuel Effect' & working in reverse order, remove the Coals/Pebbles & the Matrix.
- c. Remove the Burner/Control Assembly by firstly removing the 2 screws at the rear of the fire and disconnecting the right hand connection on the isolating elbow (to the burner valve inlet), isolating in the process. Take care not to mark the liners.

- d. Remove the Debris Plate by removing the 2 screws allowing access through the Debris Opening and clear away any Debris.
- e. Brush clean the burner and pilot area of dust or debris; check that the aeration hole in the pilot is clear of dust.
- f. Refit in reverse order; brushing the coals/pebbles clean of any soot, checking gas soundness, ignition and spillage as detailed in the relevant sections.
- g. Always Clean the outer glass panel before refitting. (For Stubborn Marks use 'T Cut Original').

ALWAYS CONDUCT A GAS SOUNDNESS AND SPILLAGE CHECK AFTER SERVICING.

ALWAYS RESEAL THE PRESSURE TEST POINT AND CHECK THAT IT IS GAS TIGHT. (This accounts for a lot of recalls.)

ALWAYS CLEAN THE GLASS PANEL BEFORE REFITTING. (This accounts for a lot of recalls.)

Note: Marks on the Glass Panel are Not Covered by the Manufactures Warranty.

21 - FAULT FINDING GUIDE, SYMPTOMS AND POSSIBLE CAUSES

Important: In instances where it is indicating that the main control system needs changing, (specifically the 3 Button High Level or Thermatronic Controls Systems), you should investigate returning the whole Burner Control System Assembly to Nu-Flame for Rectification as this could be the least cost option.

- a. Prior to any Servicing ensure that you have carried out the procedures in Section 20.1 General (Servicing).
- b. Check the supply pressure at the isolation elbow.
- c. **Important:** With the High Level and Thermatronic Systems always change the batteries before carrying out any Fault Finding.

21.1 - RESETTING THE THERMATRONIC HAND HELD RADIO FREQUENCY CONTROL SYSTEM

Full Reset - If a new handset is obtained the control system will need to learn the handset's unique code via a Full Reset. Also, if the fire is not working and the Basic Reset (described on page 7) has not worked a Full Reset can be carried out:

- a. Remove the Ash Pan Cover and locate the electronic Receiver Box.
- b. Locate the Reset Hole on the side of the Receiver and using a pen press and hold in the Reset button until you hear two beeps.
- c. The first beep is short and the second beep is long. After the second beep release the Reset Button.
- d. Now on the Handset, within the next 20 seconds press and hold the Small Flame Button until you hear two additional short beeps confirming the code is set in the Receiver.
- e. If you hear one long beep the Code as not been set so repeat the procedure.
- f. If the Handset still does not work check the wiring and or replace the Receiver and Handset .

21.2 - NO SPARK IGNITION

- a. Replace the batteries in the receiver and handset (The 2 & 3 Button High Level Systems have Receiver batteries only).
- b. Check there is no dust/debris shorting out the electrode or blocking gas from the pilot.
- c. Check the condition of the Ignition lead and ensure it is connected to both the ignition electrode and receiver. Check that the Ignition lead is not trapped and or shorting, replace if required. For the Manual System this will involve a new control, for the Thermatronic System a separate ignition lead is available.
- d. Check that gas is flowing from the pilot during the ignition sequence. Clean or Replace as required.
- e. For the 3 Button High Level & Thermatronic Controls only, listen to the control to hear if the pilot gas solenoid is opening. Change the receiver, and the handset at the same time and/or gas control. Refer to Section 22 for Cable connections diagram.

21.3 - PILOT GOES OUT AFTER FIRST LIGHTING

- a. Check there is no debris blocking the flame to the thermocouple.
- b. Check the thermocouple is tightly connected to the control.
- c. Change the pilot assembly as a new thermocouple may be required.
- d. With the Manual System or the High Level Control System change the Controls
- e. For the 3 Button High Level Control and the Thermatronic R F Systems only, listen to the control to hear if the pilot gas solenoid is opening. Change the receiver, and High Level Switch or Handset, (which ever applies), at the same time and/or the gas control. Refer to Diagram for Cable connections in Section 22.
- f. Also see Section 21.4

21.4 - PILOT LIGHTS BUT MAIN BURNER DOES NOT LIGHT

- a. With All Control Systems listen to hear if gas is flowing into the main burner.
- b. Check there is no dust or debris blocking the flame from the pilot to the main burner.
- c. With the 2 Button High Level Control check that both Control Knobs are in the on position, fully turned anti clockwise. Also check 'e' before determining the action required.
- d. With the 3 Button High Level & Thermatronic System check if the main control knob on the control is turning to the high setting and listen to hear if the valve is opening. If not change the Handset & Switch (which ever applies) and at the same time the gas control. For removal of the 3 Button Switch refer to 'f' and also refer to the Diagram for Cable connections in Section 22. Also check 'g' (below) before considering replacing any parts. You should also consider the **Important** note in 21.1.
- e. With the 2 Button High Level Control it is possible for the Main Burner to light when first lit after lighting the Pilot but then the Push Buttons do not operate the control. Operate the bottom button and listen to see if the Control Knob turns. If it does not then change the batteries, if still a problem change the Switch Assembly as detailed in 'f'.
- f. For removal/replacement of the 2 & 3 Button Switches first remove the 2 screws retaining the Switch Shield, remove the 2 screws retaining the Switch Assembly. Disconnect the push on wire connections at the control. Remove the switch and wires and replace with a new component in reverse order.
- g. All Control Systems have a Pressure Test Point to allow the Burner Pressure to be checked to confirm if gas is flowing from the control. On the Manual Control it is visible at the front left of the control. On the High Level Controls it is on the left of the control and on the Thermatronic it is at the front of the Control and is the left/rear Pressure Test Point.
- h. Check if the main injector is blocked. Clean or Replace.

21.5 - PILOT FLAME SHORTENS, OR GOES OUT WHEN MAIN BURNER IS SELECTED

- a. Monitor the supply pressure at the isolation elbow as the main burner lights. If pressure drops, check gas pipe sizing, quality of pipe bending. Check for debris in the gas supply and or gas filter if fitted.
- b. Check that another appliance is not affecting the gas supply pressure.
- c. Check the points raised in Sections 21.3 and 21.4.

21.6 - POOR FLAME PICTURE

- a. Check the supply pressure is correct at the isolation elbow. If the pressure is low, check gas pipe sizing, quality of pipe bending. Check for debris in the gas supply and or gas filter if fitted.
- b. All Control Systems have a pressure point to allow the Burner Pressure to be checked. On the Manual Control it is visible at the front left of the control.
On the Thermatronic it is present at the Front, the left pressure tapping on the Control. On the High Level Control it is on the left of the Control, the rear pressure tapping. You may wish to check 'c' first.
- c. Check that another appliance is not affecting the gas supply pressure.
- d. Check there is not a flue/ventilation problem – carry out a spillage test.
- e. Check fuel bed layout as detailed in Section 17.

21.7 - FIRE OPERATES FOR A WHILE THEN GOES OUT

- a. Check the supply pressure is correct at the isolation elbow with all other gas appliances working. If the pressure is low or fluctuating up and down check gas pipe sizing, quality of pipe bending. Check for debris in the gas supply, pilot pipe and or gas filter if fitted.
- b. Carry out a spillage test from cold. Look for signs of Discoloured Walls or Trims as this may be an indication of a Downdraught Problem.
- c. Establish how long the fire stays alight then repeat the Spillage Test around this time.
- d. For a Thermatronic System check that the Control is functioning correctly as detailed in 21.2 specifically the Thermocouple Electrical Connections and Pilot Flame size.
Downdraught problems can be related to the condition of the flue, chimney termination or geographical location and so if a Flue Problem is thought likely but no problem is found during the investigation isolate the fire and seek expert advice.

21.8 - THERMATRONIC RADIO FREQUENCY CONTROL SYSTEM DOES NOT OPERATE

- a. Check the radio frequency control is being correctly operated - see section 2.4
- b. Check for error messages and check batteries - see section 2.5
- c. Reset the Mertik Maxitrol Logic Circuits - see section 2.6

21.9 - HIGH LEVEL PUSH BUTTON CONTROL DOES NOT OPERATE

- a. Change the batteries then see if the push buttons now operate.
- b. The Switch and Receiver/Battery Box should be replaced.

Important : In instances where it is indicating that the main control system needs changing, (specifically the 3 Button High Level or Thermatronic Control Systems), you should investigate returning the whole Burner Control Assembly to Nu-Flame for rectification as this could be the least cost option.

ALWAYS CONDUCT A GAS SOUNDNESS AND SPILLAGE CHECK AFTER SERVICING.

ALWAYS RESEAL THE PRESSURE TEST POINT AND CHECK THAT IT IS GAS TIGHT. (This accounts for a lot of recalls.)

ALWAYS CHECK THAT THE GLASS IS CLEAN AND FREE FROM FINGERPRINTS. (This accounts for a lot of recalls).

VITESSE CF (Natural Gas)

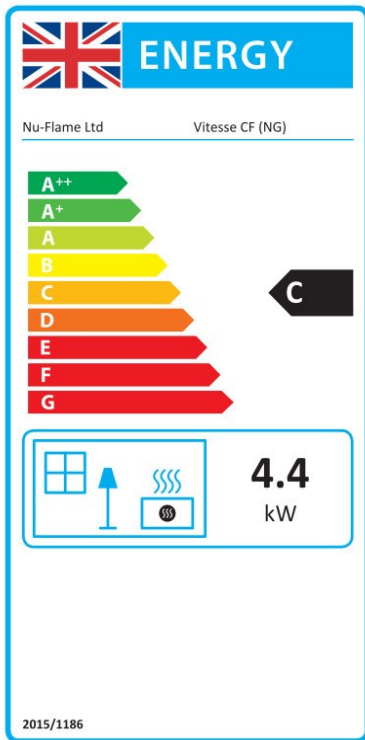

Supplier	Nu-Flame Limited
Model	Vitesse CF (NG)
Energy Efficiency Class	C
Direct Heat Output	4.4
Energy Efficiency Index	77.0
Useful Energy Efficiency at Maximum	88.0%
Useful Energy Efficiency at Minimum	72.2%
The fire must be Installed & serviced by a properly qualified (in accordance with Local & National Codes) Installation Engineer and in accordance with these Installation Instructions	

VITESSE CF (Propane)

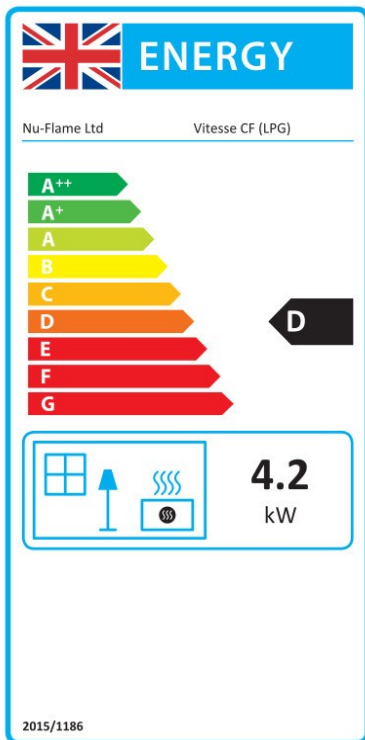

Supplier	Nu-Flame Limited
Model	Vitesse CF (LPG)
Energy Efficiency Class	D
Direct Heat Output	4.2
Energy Efficiency Index	77.0
Useful Energy Efficiency at Maximum	86.4%
Useful Energy Efficiency at Minimum	70.7%
The fire must be Installed & serviced by a properly qualified (in accordance with Local & National Codes) Installation Engineer and in accordance with these Installation Instructions	

VITESSE CF (Natural Gas)

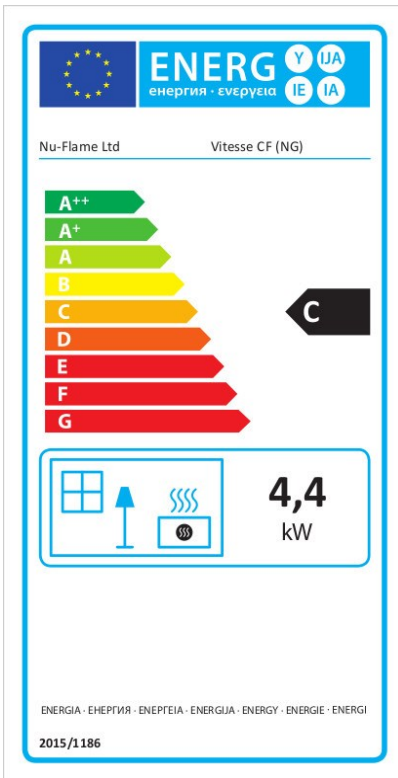

Supplier	Nu-Flame Limited
Model	Vitesse CF (NG)
Energy Efficiency Class	C
Direct Heat Output	4.4
Energy Efficiency Index	77.0
Useful Energy Efficiency at Maximum	88.0%
Useful Energy Efficiency at Minimum	72.2%
The fire must be Installed & serviced by a properly qualified (in accordance with Local & National Codes) Installation Engineer and in accordance with these Installation Instructions	

VITESSE CF (Propane)

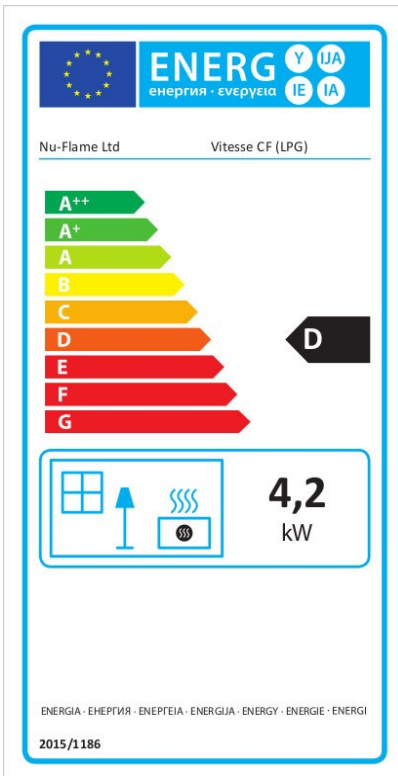

Supplier	Nu-Flame Limited
Model	Vitesse CF (LPG)
Energy Efficiency Class	D
Direct Heat Output	4.2
Energy Efficiency Index	77.0
Useful Energy Efficiency at Maximum	86.4%
Useful Energy Efficiency at Minimum	70.7%
The fire must be Installed & serviced by a properly qualified (in accordance with Local & National Codes) Installation Engineer and in accordance with these Installation Instructions	

UK Declaration of Conformity

Name of the Client : Nu-Flame Ltd
Address of the Client : Unit 4
: Kimpton Trade & Business Centre
: Minden Road
: Sutton
: Surrey
: SM3 9PF

Telephone : 020 8641 9992

Manufacturing Location : As above

This declaration of conformity is issued under the sole responsibility of the manufacturer above for:

Product : Vitesse CF

Certificate Number : UKCA 744503

The object of the declaration described above is in conformity with relevant harmonized legislation

Regulation 2016/426 on gas appliances as brought into UK law and amended.

The following harmonised standards and technical specification have been applied:

BS 7977-1: 2009 + A1: 2013 Specification for safety and rational use of energy of domestic gas appliances – Part 1: Radiant/convectors

Where the Essential Requirements of the GAR have been met and approved by Notified Body:

Responsible Test House : BSI Group
Address : Holywell Park
: Ashby Road
: Loughborough
: LE11 3AQ
: United Kingdom

Authorized Signature of Manufacturer:



Date of Issue: 19th April 2021

EU Declaration of Conformity

Name of the Client : Nu-Flame Ltd
Address of the Client : Unit 4
: Kimpton Trade & Business Centre
: Minden Road
: Sutton
: Surrey
: SM3 9PF

Telephone : 020 8641 9992

Manufacturing Location : As above

This declaration of conformity is issued under the sole responsibility of the manufacturer above for:

Product : Vitesse CF

Certificate Number : CE688450

The object of the declaration described above is in conformity with relevant harmonized legislation

Gas Appliance Regulation (EU) 2016/426

The following harmonised standards and technical specification have been applied:

BS 7977-1: 2009 + A1: 2013 Specification for safety and rational use of energy of domestic gas appliances – Part 1: Radiant/convectors

Where the Essential Requirements of the GAR have been met and approved by Notified Body:

Responsible Test House : BSI Group
Address : Holywell Park
: Ashby Road
: Loughborough
: LE11 3AQ
: United Kingdom

Authorized Signature of Manufacturer:



Date of Issue: 21st April 2018

24. - DIAGRAM OF RADIO FREQUENCY CONTROL SYSTEM

MERTIK MAXITROL

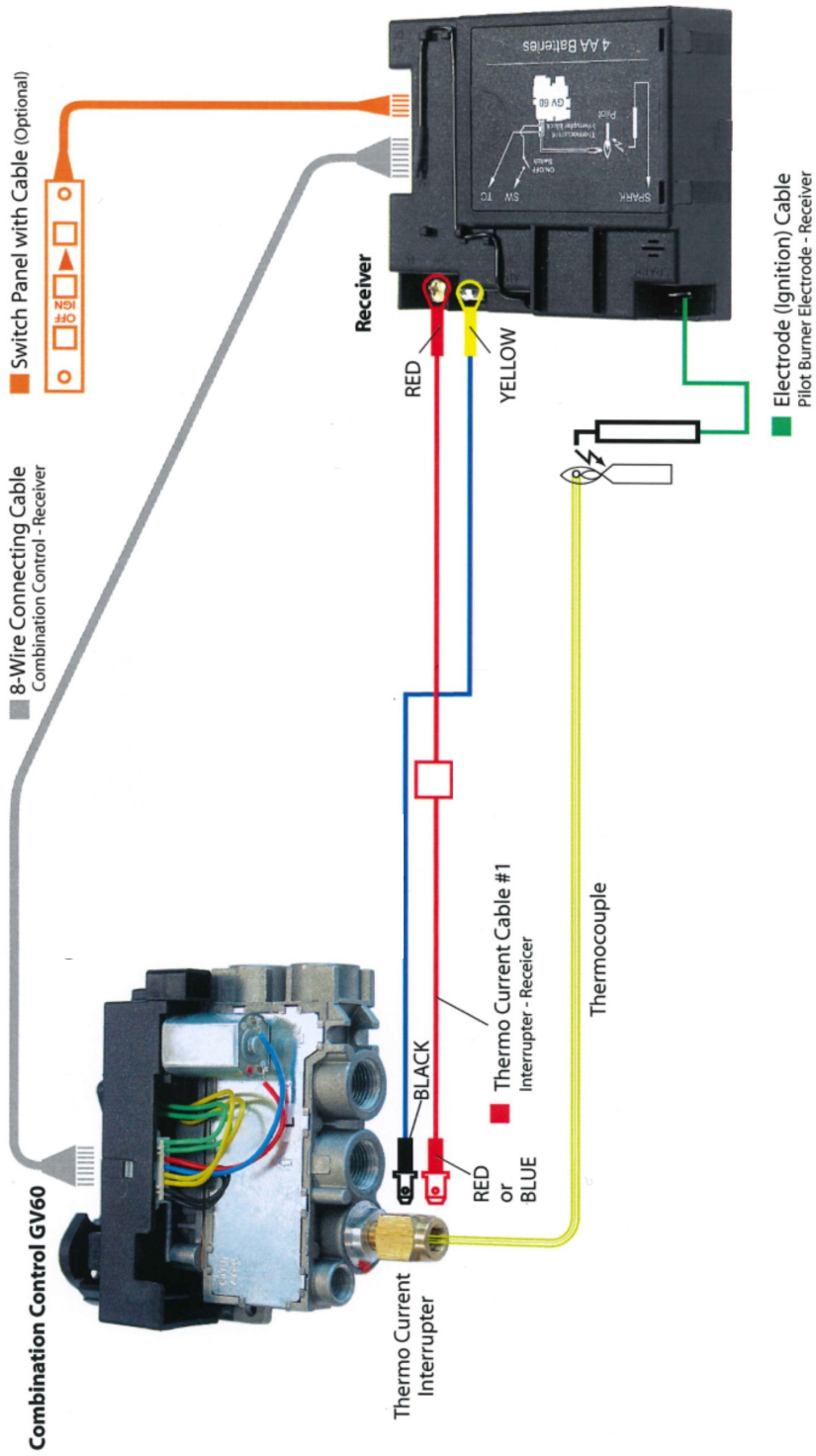



Telephone 020 8254 6802

Nu-Flame Warranty and Repair Procedure for the Vitesse CF.

Nu-Flame fires are guaranteed for 1 year from the date of purchase. During that time our guarantee is to repair at our option, or replace at no charge a fire that proves to have faulty components or workmanship.

Telephone Help Line. In the event of a problem with a fire the first course of action should be to telephone our technical department on 020 8254 6802 during normal working hours 9 - 5.30 Monday - Friday (closed 1 - 1.30). If appropriate this should be done before the installer leaves site as we may well be able to resolve the problem over the phone and in any event it may well save the installer a return visit to site. If we are not able to resolve the problem over the phone we may ask you to return the fire, and will log your details and give you a return reference number.

Returning the Fire and parts thereof. After assessment we might consider it best to return part of the appliance, such as the burner only, for testing. In this example the burner can then be thoroughly inspected and any signs of installation faults can be reported back to you. After any repair work is carried out the flow rates can be checked and re-set if necessary in order to fully comply with CE Approval. **Note:** It is a condition of the warranty that you do not return any parts to us unless we request you to do so. For example if we request that the burner only is returned and you send the entire appliance the glass and the fuel bed and other items could be damaged during the return delivery to us. We will not be liable for any such breakages.

Under no circumstances should any attempt be made to repair the burner on site without our express knowledge and approval during the warranty period.

This guarantee is given subject to the following provisions:

1. That the installation is carried out by a CORGI registered installer (we may require their registration details).
2. That the appliance is installed and used in accordance with our Installation & User instructions.
3. That the gas supply pressure at the appliance is not more than 3mbar below the gas pressure stated on the data plate when the appliance is running on high flame, with any other major gas appliances also running.
4. That the fireplace and flue system conform to relevant local codes, building regulations and British Standards.
5. This Guarantee is not transferable and relates to the original installation only.
6. The appliance has not been subject to misuse or accident or been modified or repaired by any person other than the authorised employee or authorised representative of Nu-Flame Ltd.
7. The Record Data section on the front of the Installation & Servicing Instructions is to be completed on installation.
8. Nu-Flame Ltd accepts no liability for any consequential loss or damage arising from the use or failure of the product or any information provided, including, but not limited to, economic or financial loss, damage to peripheral equipment or products, loss of use, productivity or time.
9. That the serial no. data plate on the burner is intact.

This guarantee in no way reduces your statutory rights.

This guarantee supersedes any previously published guarantees.

Chargeable Repairs During And After The Warranty Period

If a repair is chargeable during the warranty period, due to installation faults we will inform you and where possible give you a quote, or if this is not possible, a price guide before starting work. We cannot always give a firm cost until we commence the repair as it is not always possible to tell which components have been damaged.